

# INSTRUCTION MANUAL

## E110-R ECO



EN

Instruction manual  
(Original instruction)



Attention: Read the instruction before use  
the machine





# CONTENT INDEX

<b>PRESENTATION</b> .....	<b>4</b>
<b>MACHINE IDENTIFICATION</b> .....	<b>5</b>
<b>GENERAL WARNINGS AND ADVICE</b> .....	<b>6</b>
<b>UNPACKING</b> .....	<b>9</b>
<b>MACHINE DESCRIPTION</b> .....	<b>12</b>
<b>MAIN FUNCTIONS AND CONTROLS</b> .....	<b>14</b>
BRAKE PEDAL.....	17
BRAKE PEDAL ADJUSTMENT .....	17
BRUSHES REPLACEMENT/ ROTATION .....	17
ADJUSTING THE SQUEEGEE .....	18
MOUNTING THE SQUEEGEE .....	18
ADJUSTING THE QUANTITY OF SOLUTION ON THE BRUSHES (WATER + DETERGENT) .....	19
FILLING THE DETERGENT SOLUTION TANK.....	19
SPLASH GUARD LIFTING FOR PRE-WASHING .....	20
DETERGENT DOSING DEVICE .....	20
DETERGENT DOSING SYSTEM WASHING.....	21
DETERGENT DOSING SYSTEM CONTROLS.....	21
BRUSH AND WATER PUMP CUT-OUT SWITCH.....	21
<b>USING THE MACHINE</b> .....	<b>22</b>
<b>MAINTENANCE</b> .....	<b>23</b>
DRAINING AND CLEANING THE RECOVERY TANK.....	23
CLEANING INSTRUCTIONS ECO-SYSTEM.....	24
DRAINING AND CLEANING THE SOLUTION TANK.....	24
CHECKING BRUSHES OR ABRASIVE DISCS.....	25
CLEANING THE DETERGENT SOLUTION FILTER .....	25
CLEANING THE SQUEEGEE .....	25
REPLACING SQUEEGEE BLADES.....	26
ROTATING OR REPLACING THE SPLASHGUARD BLADES.....	26
CLEANING THE DIRT CONTAINER .....	27
CLEANING THE DETERGENT SOLUTION DISTRIBUTOR.....	27
CHECKING AND REPLACING FUSES .....	28
GREASING POINTS .....	29
CHECKING OR REPLACING THE OIL OF THE DRIVE WHEEL REDUCER .....	29
CLEANING THE SUCTION FILTER.....	29
CHECK THE SEAL ON THE COVER .....	30
RECHARGING BATTERIES .....	30
<b>DIMENSIONAL TECHNICAL DRAWINGS</b> .....	<b>31</b>
<b>TECHNICAL CHART</b> .....	<b>32</b>
<b>OPTIONAL</b> .....	<b>34</b>
RIGHT SIDE SWEEPING BRUSH EXTENDIBLE.....	34
RIGHT SIDE SCRUBBING BRUSH EXTENDIBLE.....	35
RIGHT AND LEFT SIDE SWEEPING BRUSH NO EXTENDIBLE.....	37
<b>SERVICE AND MAINTENANCE RECORDS</b> .....	<b>39</b>
<b>TROUBLE-SHOOTING CHART</b> .....	<b>45</b>
<b>EU DECLARATION OF CONFORMITY</b> .....	<b>52</b>

**FROM FRAME 110005670524**

# PRESENTATION

*Our company, a leader in the production of industrial cleaning machines, is delighted to have you among the owners of this scrubber and is sure you will be fully satisfied with it. We are sure that during its use, you will see the quality, robustness and possibilities of use it has to offer. This scrubber is suitable for private, industrial or public use. This manual describes the various installation operations, controls and maintenance interventions necessary to maintain perfect efficiency of your scrubber. These are normal maintenance operations that any operator can carry out using devices normally available in a company. For particular works, please contact specialist staff.*

OUR COMPANY AIMS TO CONSTANTLY IMPROVE ITS PRODUCTS AND RESERVES THE RIGHT TO MAKE CHANGES AND IMPROVEMENTS WHEN NECESSARY WITHOUT ANY OBLIGATION TO UPGRADE PREVIOUSLY SOLD MACHINES.

## ATTENTION!

### **THE MACHINE IS NOT CERTIFIED FOR ON-ROAD USE.**

BEFORE USING THE MACHINE OR CARRYING OUT ANY OPERATION ON IT, ALL THE PROCEDURES AND WARNINGS DESCRIBED IN THIS MANUAL MUST BE READ AND UNDERSTOOD. STRICT COMPLIANCE WITH THE REGULATIONS AND THE INSTRUCTIONS CONTAINED IN THIS MANUAL, COMBINED WITH THE OPERATOR'S ATTENTION AND CAUTION, WILL BE THE BEST GUARANTEE AGAINST ACCIDENTS THAT CAN OCCUR IN THE WORKPLACE.

SCRUBBERS ARE DESIGNED TO PROVIDE UTMOST SAFETY IF USED ACCORDING TO INSTRUCTIONS. THIS MACHINE IS INTENDED FOR COMMERCIAL USE, FOR EXAMPLE IN HOTELS, IN SCHOOLS, IN HOSPITALS, IN FACTORIES, IN SHOPS, IN OFFICES AND IN BUSINESSES.

THIS MACHINE IS NOT INTENDED FOR USE BY PEOPLE (INCLUDING CHILDREN) WITH REDUCED PHYSICAL, SENSORY OR PSYCHOLOGICAL CAPACITY, OR WITH LACK OF EXPERIENCE AND KNOW-HOW. CHILDREN SHOULD BE MONITORED TO ENSURE THEY DO NOT USE THE EQUIPMENT TO PLAY ON.

THE USER MANUAL IS AN INTEGRAL PART OF THE SCRUBBER AND MUST ACCOMPANY IT UP TO ITS DEMOLITION.

PURSUANT TO DIRECTIVE 2006/42 EC, AND DPR 459 ON 24/07/1996 AND SUBSEQUENT UPDATES, IT IS MADE KNOWN THAT: OPERATOR IS INTENDED AS THE PERSON OR PEOPLE RESPONSIBLE FOR INSTALLING, OPERATING, ADJUSTING, CARRYING OUT ROUTINE MAINTENANCE, CLEANING, REPAIRING AND TRANSPORTING THE MACHINE.

THIS COMPANY CANNOT BE HELD LIABLE FOR PROBLEMS, BREAKAGES, ACCIDENTS OR OTHER ISSUES DUE TO LACK OF KNOW-HOW OR NON-APPLICATION OF THE PROCEDURES CONTAINED IN THIS MANUAL, OR DUE TO IMPROPER USE OF THE MACHINE.

THIS COMPANY ALSO CANNOT BE HELD LIABLE FOR CHANGES, INSTALLATION OF PARTS AND/OR ACCESSORIES WITHOUT PRIOR AUTHORISATION.



### **EMERGENCY SITUATIONS**

**IN THE EVENT OF FIRE, ONLY USE POWDER EXTINGUISHERS  
IF OCCURS ANY ABNORMAL BEHAVIOR (UNCONTROLLED SPEED INCREASE,  
OVERHEATING, ...) TURN OFF THE MACHINE IMMEDIATELY**

# MACHINE IDENTIFICATION

The machine and manufacturer are identified through three plates on the left of the driver's seat.

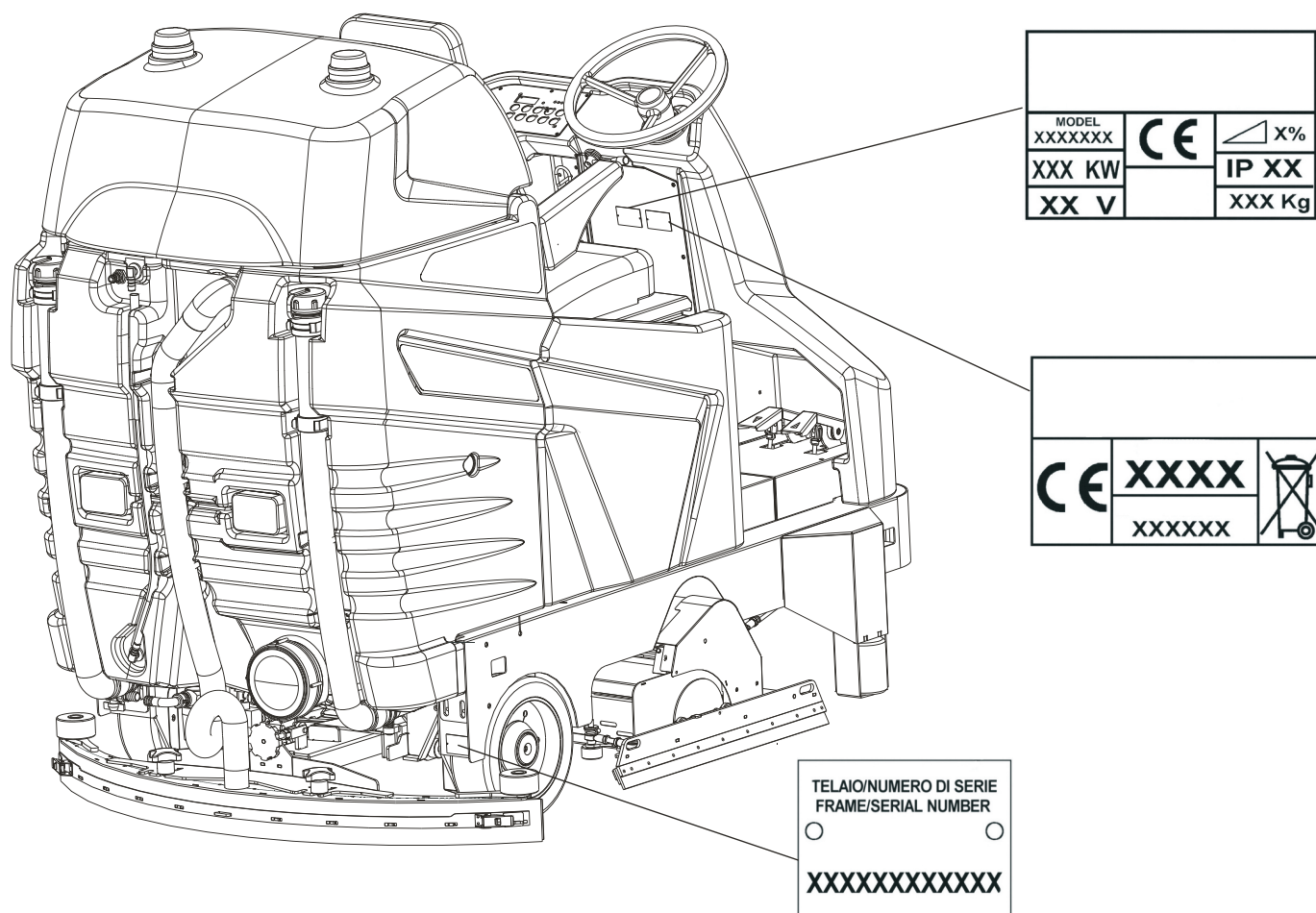

REFER TO THESE DETAILS TO ORDER SPARE PARTS OR WHEN SENDING ANY REQUEST TO THE MANUFACTURER.

The scrubbers comply with EEC directives and display the CE logo.

# GENERAL WARNINGS AND ADVICE

## DANGER - ATTENTION SIGNS



THIS SYMBOL HIGHLIGHTS ALL THE OPERATIONS THAT REPRESENT A SITUATION OF POTENTIAL DANGER FOR THE OPERATOR.  
THEREFORE, PROCEED IN COMPLIANCE WITH THE CONDITIONS HIGHLIGHTED BY THIS SYMBOL



USE OF GLOVES COMPULSORY



USE OF GOGGLES COMPULSORY



ATTENTION: MOVING PARTS, RISK OF TRAPPING HANDS



ATTENTION: DO NOT WET  
THE DEVICES MARKED WITH THIS INDICATION MUST NOT GET WET  
(THEY ARE NORMALLY ELECTRICAL COMPONENTS)



USE OF ANTI-VAPOUR MASKS WHEN USING CORROSIVE DETERGENTS



## RESPONSIBILITIES OF THE OPERATOR

- The operator is responsible for the day-to-day servicing of the machine;
- The operator must care for the machine and keep it in good operating condition;
- The operator must inform his or her superior or the technical department when scheduled maintenance is requested in the case of damage or breakage;
- The operator must not carry people, animals or objects on the machine;
- When moving the machine, observe the safety measures for circulation;
- The machine cannot be used for toxic-harmful materials;
- Never let people get close to the machine's sphere of action;
- Never leave the scrubber-dryer with the key and the emergency switch inserted;
- Engage the hand brake;
- If the machine malfunctions, have a look at the procedures shown in the various chapters;
- Never collect pieces of string, wire or anything else that could damage the brushes by winding around them;
- Never suck up pieces of wood, plastic waste etc. as they may clog the vacuum pipe;
- Never remove or alter the plates on the machine.

## IMPORTANT COMMUNICATION

WARNING! DURING THE LAST FEW YEARS, A NEW AGGRESSIVE SOLVENT-BASED DETERGENT TYPE WAS MADE AND DISTRIBUTED IN THE MARKET. THIS DETERGENT IS CURRENTLY NAMED AS "DETER-SOLVENT". EVEN IF THE SOLVENT CONTAINED IN THE DETERGENT IS OBTAINED FROM THE FRUITS, IT STILL HAS TO BE CONSIDERED AS "SOLVENT". THE POLIETHYLENE MATERIAL USED IN THE SCRUBBER TANKS IS MIXED WITH A % OF RUBBER. THE "DETER-SOLVENT" PRODUCT, IF LEFT IN THE SCRUBBER'S TANKS FOR A LONG PERIOD OF TIME COULD ATTACK THE RUBBER'S MOLECULAS, CAUSING THE TANK TO SWELL AND CRACK. IF THE "DETER-SOLVENT" PRODUCT IS USED, IT'S MANDATORY TO RINSE THE TANKS PROPERLY WHEN THE MACHINE STOPS WORKING.



## CLEANING AND MAINTENANCE

Machine cleaning must be carried out by staff correctly trained for the purpose, who know the controls to bypass energy sources and are familiar with the characteristics of the machine to avoid dangerous situations.

Clean the coverings of the machine, the panels and the controls with a cloth soaked in water or detergent solution.

No solvents must be used such as petrol, alcohol, etc.

Have specialist staff clean the electrical components who should use non-corrosive products, suitable for electrical circuits.

Maintenance of the machine must be carried out by specialist staff with in-depth knowledge of the machine and its components.

Any maintenance and cleaning must be carried out with the machine off, with all the mechanisms stopped, the hot parts cooled and the battery disconnected.

When using compressed air guns for cleaning, protect eyes and ears.

### STORAGE OF THE MACHINE

If the machine is unused for long periods of time, it is essential to:

- Recharge the batteries before storing the machine as empty batteries may get damaged;
- Empty and wash the tanks as described in the relative section;
- Remove the detergent can if fitted;
- Clean the filter on the detergent suction pipe in the can;
- Wash the detergent dosing system;
- Clean the clean water filter, empty the filter protection and drain the water completely from the system;
- Clean the ECO-SYSTEM circuit and allow for water-flowing;
- Clean the machine inside and outside;
- Keep brushes and squeegee raised;
- Lock the machine in place with the parking brake and remove the key;
- Remove the battery lead connections;
- Keep the machine in a protected place, within a temperature range of 5°C / 40 °C and a humidity range of 30 % / 80 %;



## SAFETY PRECAUTIONS FOR OPERATORS AND TECHNICIANS

- The machine must not be used by non-authorized personnel who have not been trained to use it properly or by people who are under the influence of substances that could alter their nervous reflexes (alcohol, psycho pharmaceuticals, drugs etc.)
- Do not use the machine in inflammable areas or where there is the danger of explosions;
- Do not collect material that is alight or anything else that could cause a fire;
- Do not remove protections or guards when the machine is in operation;
- Do not use the machine to clean objects;
- Do not start to perform maintenance operations with parts in movement;
- Protect eyes and ears when using compressed air or water guns for cleaning the machine;
- To raise the machine make use of devices that are adequate to bare the weight of the machine itself;
- Do not cause flames or sparks around the machine;
- Disconnect the battery cables before working on the electrical circuit;
- Avoid contact with battery acid;
- Move carefully over uneven or crumbling paving and on slopes;
- Slow down on slopes and slippery surfaces;
- Make sure the machine is not exposed to rain and bad weather conditions, whether in motion or still;
- Temperature of usage of the machine must be kept within + 5 °C / + 40 °C;
- Humidity should be kept within 30% / 80 %.

### UPDATING OF THE USER'S MANUAL

When large-scale modifications are made to the machine or new parts are installed, the updated documentation must be sent to the Dealer along with the purchased part or as an update of the manual.

### OBLIGATIONS OF THE EMPLOYER OR OWNER OF THE MACHINE

The employer or owner of the machine is responsible for giving the User's Manual to all the personnel who are going to have to use the machine.

The employer or owner of the machine also undertakes to update the manual with the documentation that the Manufacturer will send if modifications are made to the machine.

# DISPOSAL



All packaging is recyclable. The packaging should not be thrown away with domestic waste, but sent to the relevant collection centres.



## EXHAUSTED LEAD-ACID BATTERIES

Exhausted batteries are considered harmful toxic waste and therefore should be exclusively given to collection companies with specific authorisation (ascertain on hand-over).

## MATERIAL COLLECTED FROM THE MACHINE

The waste collected by the machine must be given to the relevant urban cleaning company since it is considered urban waste or similar. The machine cannot be used to collect toxic-harmful materials.

## SCRAPPING THE MACHINE

On scrapping, proceed with the correct disposal of the materials that make up the machine. It is compulsory to give the machine to authorised collection companies which will correctly dispose of oil, filters, plastic, metal, electric motors, electric boards, etc. in compliance with legislation in force. Decommissioned equipment contains precious recyclable materials and therefore should be given to the relevant collection centres. Please dispose of decommissioned equipment through differentiated collection systems.

## DISPOSAL OF THE RECOVERY TANK SOLUTION

Prior to be moved to specific purification plants, the recovery tank solution is to be disposed of in appropriate sites.



## DISPOSAL OF ELECTRICAL EQUIPMENT AND ELECTRONICS



## TRANSPORT

The machine must be fixed to a pallet to make it easier to transport and more secure.

At the reception of the machine, check that the packaging is in good condition –in case of damage, inform the forwarder.

**PAY ATTENTION WHILE TRANSPORTING THE MACHINE AT TEMPERATURES BELOW 0°C TO PREVENT THE WATER INSIDE THE TANKS AND THE PIPES FROM BECOMING FROZEN.**

**DRAIN THE TANKS, REMOVE THE SCREEN OF THE CLEAN SOLUTION FILTER AND LET THE WATER FLOW AWAY COMPLETELY OUT OF THE PIPES.**



## TRANSPORT- HANDLING

When the machine is moved from one place to another you are advised to:

- Not load it on the vehicle with a forklift truck in order not to damage it;
- Lock the machine in place with the parking brake;
- Fix it well to the vehicle using belts, ropes and chains;



## TRANSPORTING THE MACHINE BY MANUAL PUSHING

In case of transport by means of manual pushing, for machines featuring electronic traction only, the machine must be pushed on at walking pace. Do not tow it with fork lifts



## UNPACKING

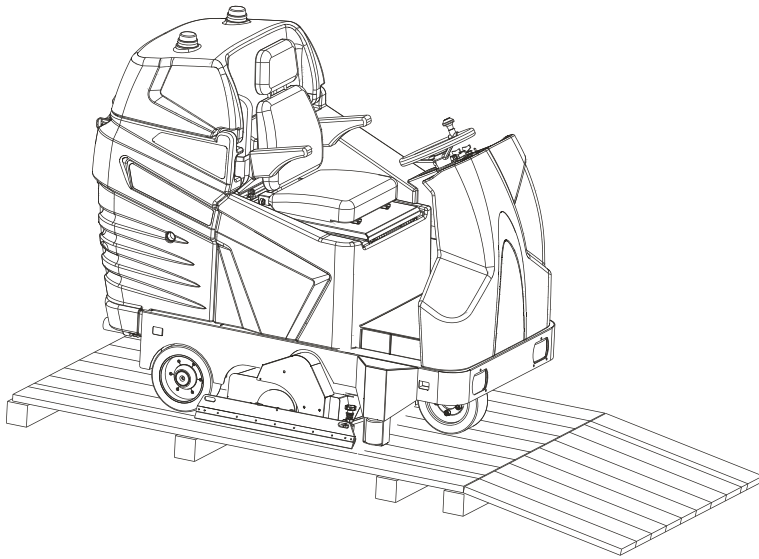

Make sure that all the parts indicated in the following list are present before unpacking the machine:

- squeegee;
- battery cable fitted with connector, terminals and terminal covers;
- on board battery charger.

NOTICE: brushes, discs and disc pad holders must be purchased separately

Follow the instructions below to unpack the machine:

- Connect the inclined ramp to the front part of the pallet, as shown in the figure;
- Remove the fasteners fixing the front wheels and eventual other devices;
- Make use of the inclined ramp;

**CAUTION: DO NOT USE A FORKLIFT TO REMOVE THE MACHINE FROM THE PALLET AS IT MAY CAUSE DAMAGE TO THE MACHINE.**



## INSTALLING BATTERIES

**CAUTION: USE PROTECTIVE GLOVES AND GOGGLES WHEN HANDLING BATTERIES, AVOIDING ANY CONTACT WITH THE ACID INSIDE THE BATTERIES.**

**CAUTION: THE MACHINE'S CONTROL BOARD AND BATTERY CHARGER COME OFF THE ASSEMBLY LINE CONFIGURED FOR USE WITH LEAD ACID BATTERIES. IF GEL BATTERIES OR AGM BATTERIES ARE USED, THE MACHINE'S CONTROL BOARD AND THE BATTERY CHARGER MUST BE SET.**

**CONTACT A RESELLER OR A TECHNICIAN BEFORE MOUNTING THESE TYPES OF BATTERIES.**

Refer to the specification sheet for battery types and sizes suitable for the machine.

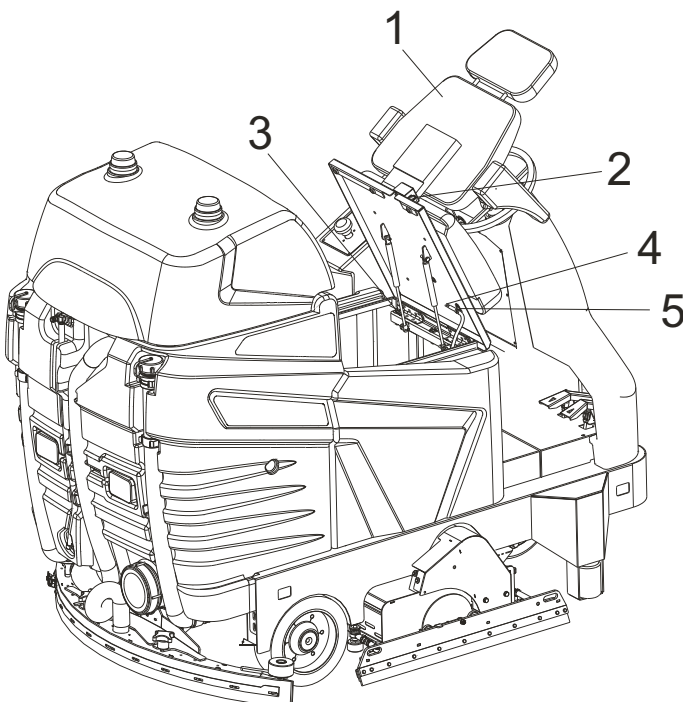

Follow the instructions below to mount the batteries on the machine:

- Park the machine on a flat surface, put on the brake and remove the key;
- Open the hood of the seat pos.1 by releasing the special safety hook pos.2;
- Remove the nut pos.5;
- Unplug the seat safety device cables pos.7;
- Remove the 3 screws pos.3;
- Lift the hood pos.1;

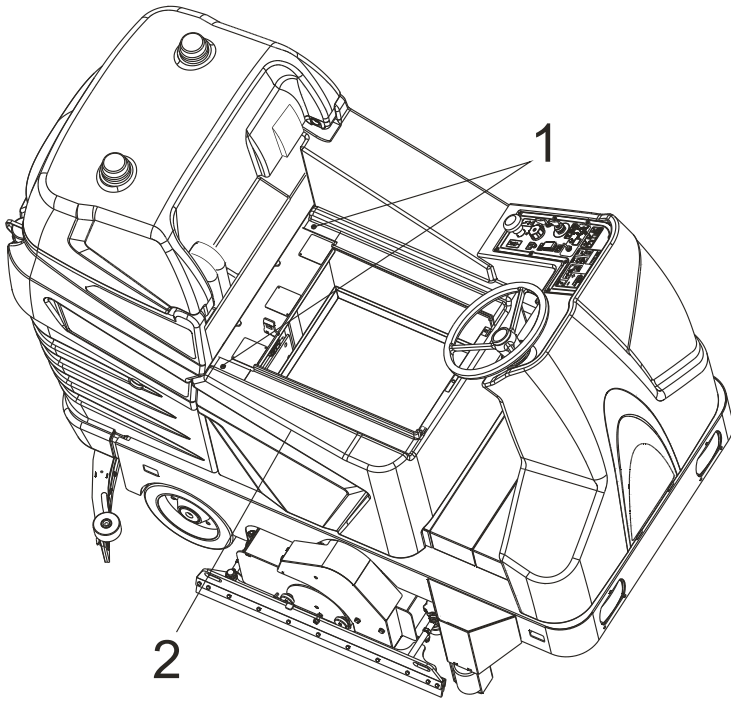

- Remove the 2 screws pos.1;
- Remove the battery hood pos.2;

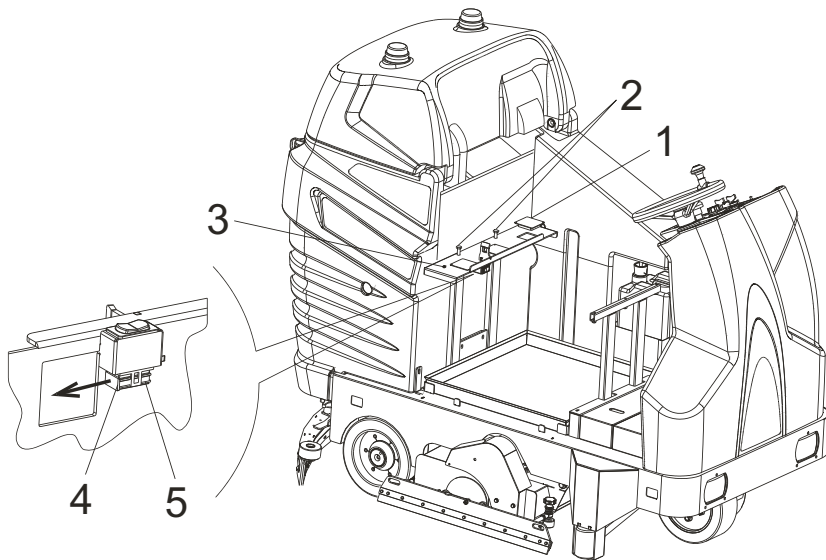

- Remove the 3 metal plate caps pos.1;
- Remove the 2 bolts pos.2;
- Pull the safety lever pos.4 in the direction indicated by the arrow and remove the connector pos.5 from the switch;
- Remove the seat rest plate pos.3;

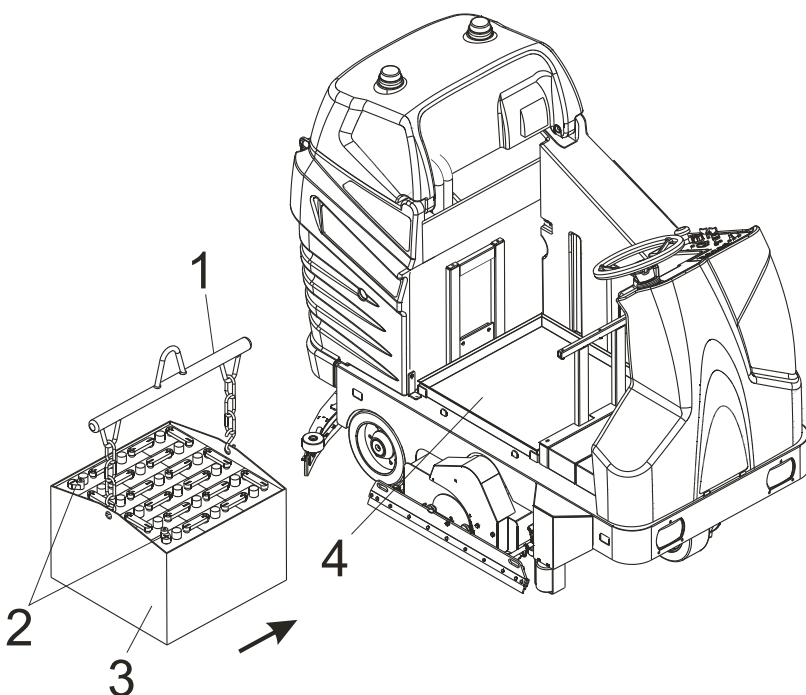

- To install the battery pos.3, lift it with an overhead travelling crane, a carriage or a crane and use a lifting beam pos.1, chains or belts to fasten it;
- Position the battery inside the compartment provided pos.4 on the machine by fitting it in the direction indicated by the arrow and not lowering it from above. Position the poles pos.2 towards the right of the machine as shown in the illustration.

## BATTERY CONNECTION

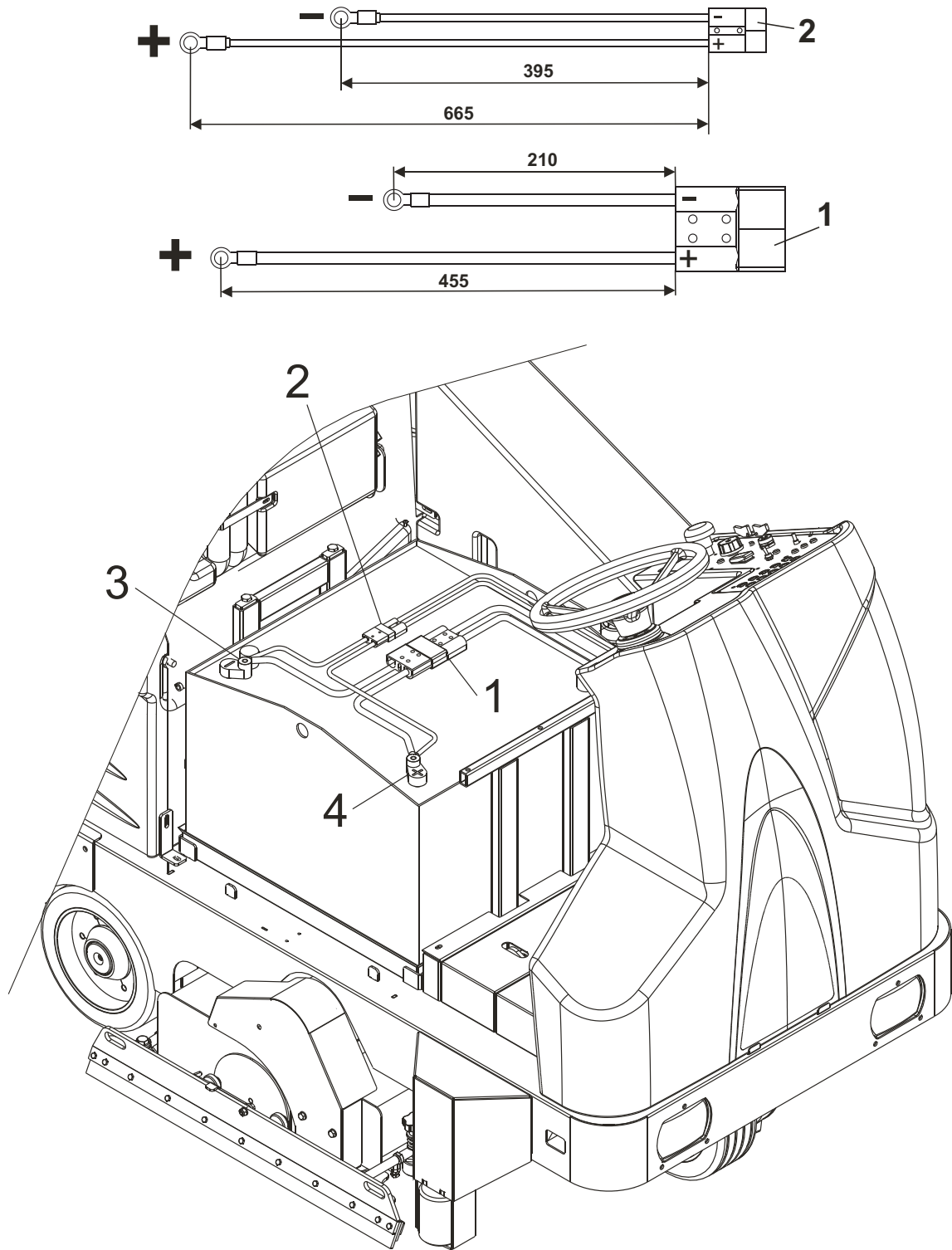

- After positioning the battery on board the machine, connect the cables.
- The machine features 3 connectors shown in figure A:
  - Battery connector for supplying power to the machine;
  - Battery-charger connector.
- Connect the cables of connectors 1 and 2 to the negative pole 3 and positive pole 4 in accordance with the polarities;
- Connect connectors 1-2 to the respective connectors on the machine;
- Fit all the machine components back on and connect them up again;

# MACHINE DESCRIPTION

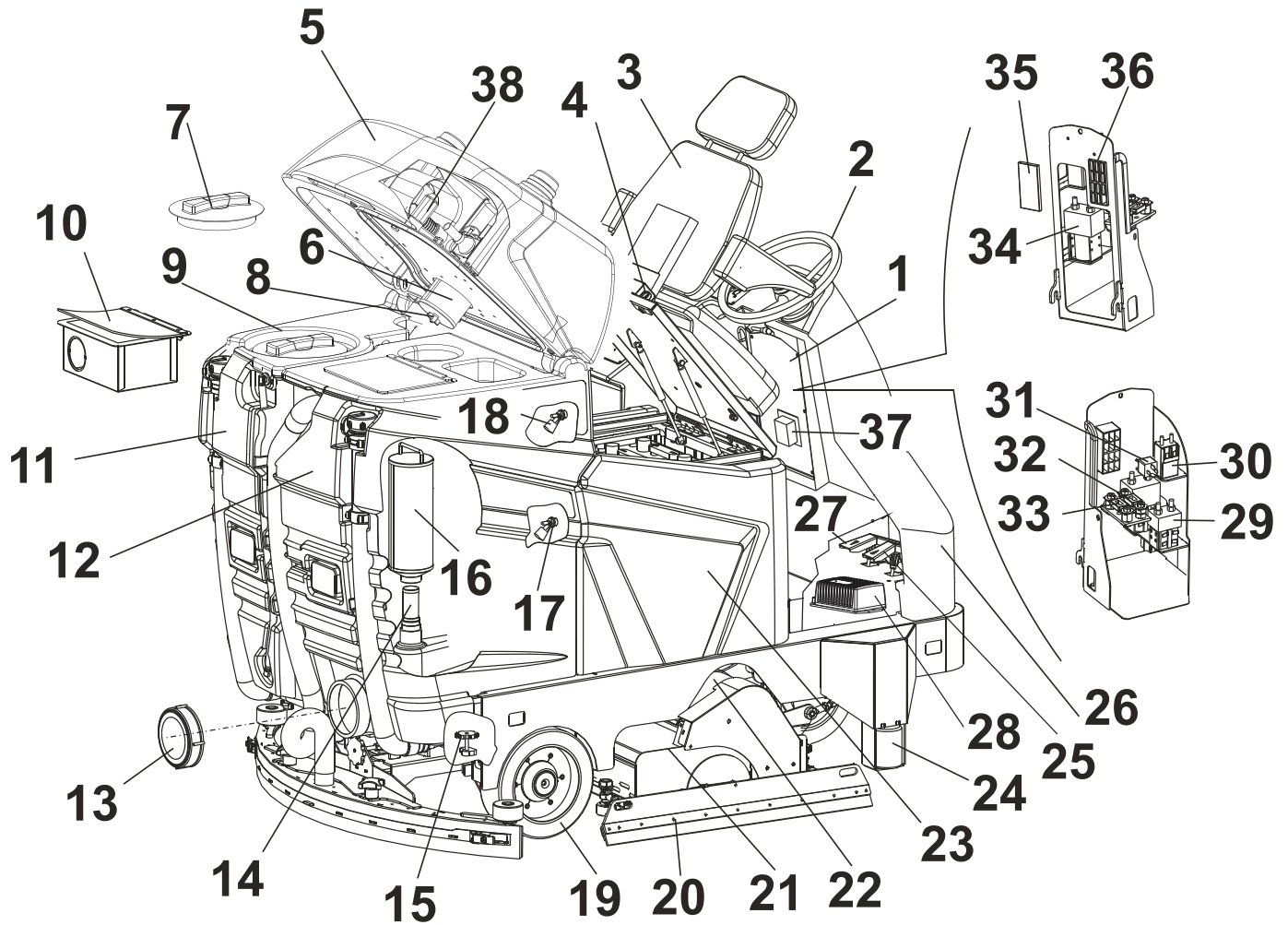

- |  |  |
|--|--|
| 1. FUSES INSPECTION DOOR                               | 21. BRUSH TRAY                           |
| 2. HAND WHEEL  | 22. BRUSH MOTOR                          |
| 3. SEAT  | 23. BATTERY SEAT                         |
| 4. HOOD AND SEAT OPENING DEVICE                        | 24. BUMPER ROLLER                        |
| 5. LID AND VACUUM MOTOR SEAT                           | 25. FORWARD MOVEMENT PEDAL               |
| 6. VACUUM FILTER                                       | 26. MACHINE FRONT NOSE                   |
| 7. SOLUTION TANK LID                                   | 27. BACKWARD MOVEMENT PEDAL              |
| 8. BLOCKING FILTER DEVICE                              | 28. DRIVE CONTROL CARD                   |
| 9. FILLING-IN SOLUTION                                 | 29. BRUSH REMOTE SWITCH                  |
| 10. GATHERING MATERIAL GASKET                          | 30. SUCTION UNIT REMOTE SWITCH           |
| 11. SOLUTION TANK                                      | 31. RELAY                                |
| 12. RECOVERY TANK                                      | 32. 80A BRUSH INPUT PEAK PROTECTION FUSE |
| 13. RECOVERY TANK INSPECTION HATCH CAP                 | 33. 125A DRIVE SYSTEM PROTECTION FUSE    |
| 14. ECO-SYSTEM SAFETY FILTER                           | 34. FORWARD MOVEMENT REMOTE SWITCH       |
| 15. SQUEEGEE MAXIMUM PRESSURE ADJUSTMENT               | 35. FUSE HOLDER COVER                    |
| 16. ECO-SYSTEM FILTER                                  | 36. FUSE HOLDER                          |
| 17. ECO-SYSTEM FLOATING DEVICE                         | 37. CUT OUT SWITCH                       |
| 18. MAXIMUM LEVEL FLOATING DEVICE OF THE RECOVERY TANK | 38. ECO-SYSTEM CLEANING DEVICE           |
| 19. REAR WHEEL   |  |
| 20. SPLASHGUARD  |  |

# MACHINE DESCRIPTION

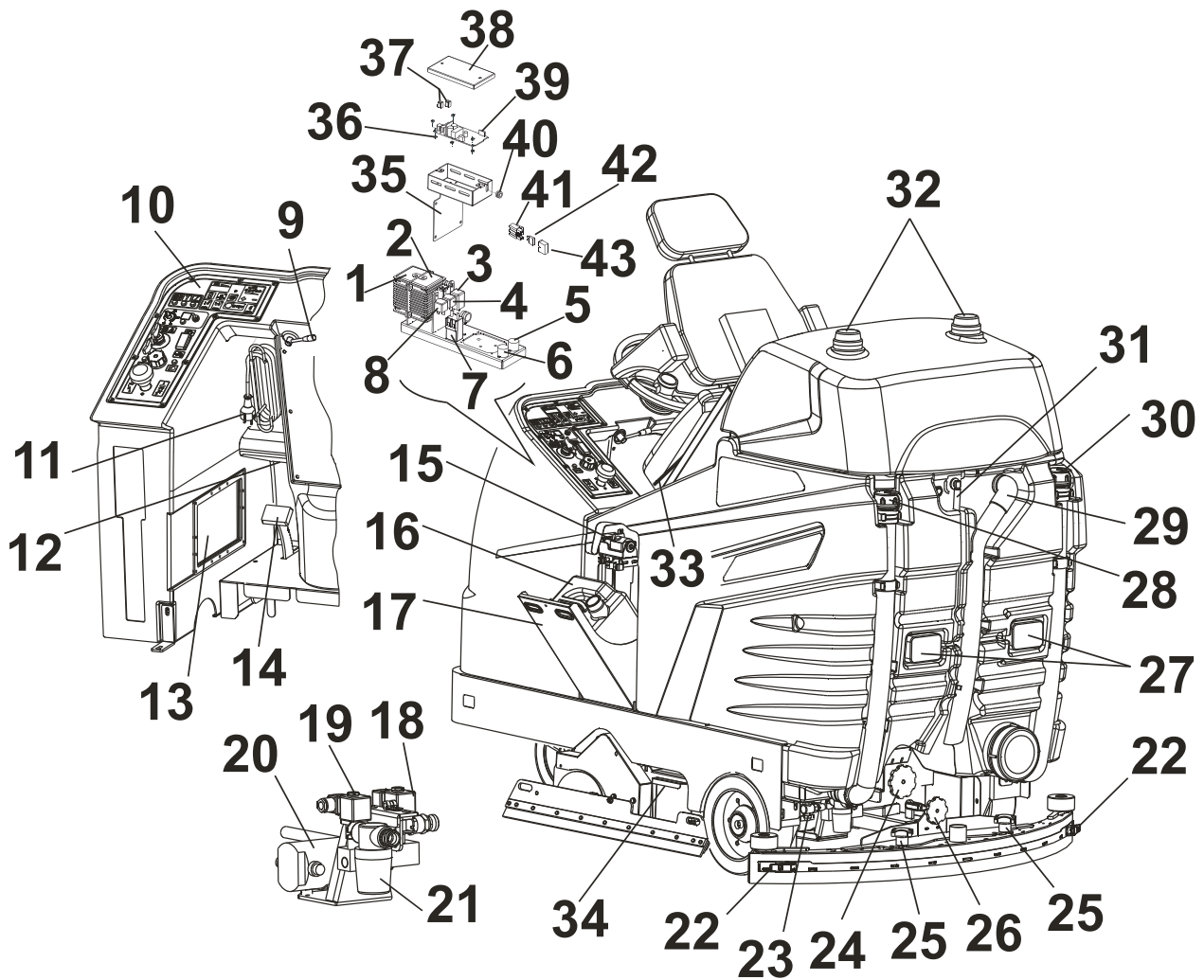

- |   |   |
|---|---|
| 1. TRANSFORMER N°2 36V-24V (LIGHTS)           | 23. CLEAN WATER TANK TAP                      |
| 2. TRANSFORMER N°1 36V-24V (SERVICES)         | 24. SQUEEGEE ADJUSTING PRESSURE HAND WHEEL    |
| 3. FLASHING LIGHT INTERMITTENCE               | 25. SQUEEGEE LOCKING KNOBS                    |
| 4. REVERSE LIGHT RELAY                        | 26. SQUEEGEE ADJUSTING INCLINATION HAND WHEEL |
| 5. HANDBRAKE ENGAGED BUZZER                   | 27. REAR LIGHTS                               |
| 6. MOTOR TEMPERATURE ALARM BUZZER             | 28. SOLUTION DRAIN PIPE                       |
| 7. SERVICE REMOTE SWITCH                      | 29. SQUEEGEE VACUUM PIPE                      |
| 8. DRIVE MOTOR TEMPERATURE ALARM RELAY        | 30. RECOVERY TANK DRAIN PIPE                  |
| 9. PARKING BRAKE LOCKING AND UNLOCKING DEVICE | 31. SOLUTION TANK LEVEL                       |
| 10. CONTROL PANEL                             | 32. FLASHING LIGHTS                           |
| 11. BATTERY CHARGER CABLE                     | 33. SEAT ADJUSTING LEVER                      |
| 12. COOLING FAN (BATTERY RECHARGE PHASE)      | 34. DIRT CONTAINER                            |
| 13. BATTERY CHARGER                           | 35. CARD BOX                                  |
| 14. PEDAL BRAKE                               | 36. SPACER                                    |
| 15. DETERGENT PUMP                            | 37. CONNECTOR                                 |
| 16. DETERGENT CAN                             | 38. COVER                                     |
| 17. DETERGENT CAN COMPARTMENT                 | 39. CONTROL CARD                              |
| 18. ECO-SYSTEM SOLENOID VALVE                 | 40. FAIR LED                                  |
| 19. CLEAN WATER SOLENOID VALVE                | 41. FUSE HOLDER                               |
| 20. SOLUTION PUMP                             | 42. FUSES 5A                                  |
| 21. CLEAN WATER FILTER                        | 43. COVER                                     |
| 22. REAR BLADE LOCKING PLATE HOOK             |   |

# MAIN FUNCTIONS AND CONTROLS

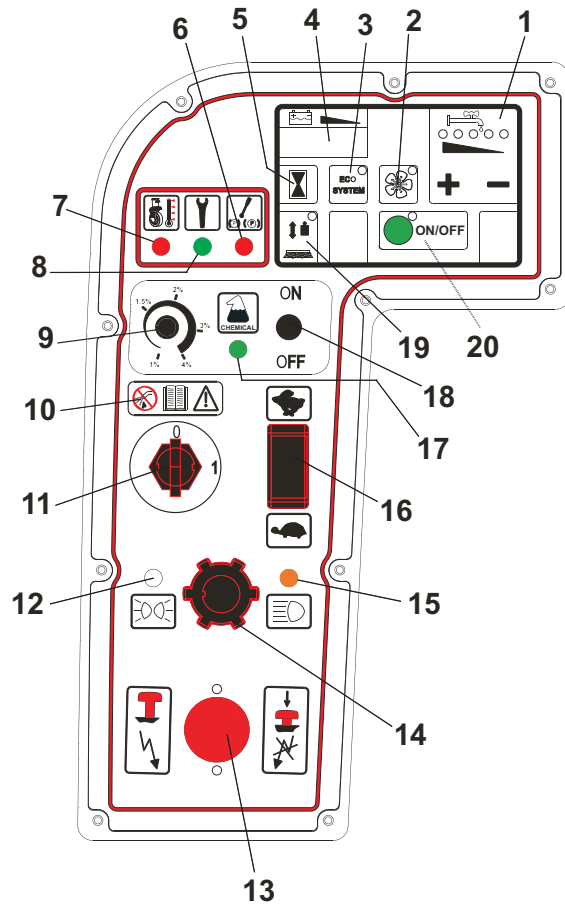

## WATER ADJUSTMENT BUTTONS

Use the buttons + or - to set the maximum quantity of water to use for the operation.

Press the + button to increase the quantity of water; the 5 green led lights on the panel come on progressively one at a time.

Each led light is associated with a maximum pre-set quantity of water.

Press the - button to decrease the quantity of water; the 5 led lights will go out progressively one at a time. The water is shut off when all the led lights are off. The machine keeps memory of the preset quantity of water even when switched off. If the 5 led lights start flashing at the same time, this means that there is no solution into the tank.

1

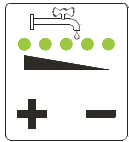

## SUCTION FAN BUTTON

If the suction fan is switched off, this button can be used to turn it on, the squeegee lowers and a green light indicator will come on.

If the suction fan is switched on, the light will start flashing, when this button is pressed, but the suction function will remain active for a fixed period of time and once lapsed the squeegee will lift and the suction function will come off. The warning light will start flashing even when the machine is in reverse drive to indicate that the squeegee is being raised from the floor. The suction function may turn off automatically when the solution on the recovery tank is too full. The machine is equipped with a float that switches off the function when the tank reaches its maximum level. In case of prolonged idle time, the suction fan will switch off automatically after 1 minute regardless of whether the squeegee does not lift automatically from the floor for safety reasons but must be lifted by pressing the button. By pushing the vacuum button the automatical ECO-SYSTEM cleaning device will be activated. This will keep filters and conduits clean during the use of the ECO-SYSTEM. Every 2 minutes a valve will be activated and you will hear a mechanical noise.

2

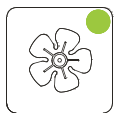

## ECO-SYSTEM OPERATION BUTTON

Press this button to enable the ECO-SYSTEM.

The green light is on when the system is operating.

If the button is pressed and the led light does not come on, it means that the solution level on the recovery tank is too low and therefore, the function cannot be enabled. Continue to wash in "normal" mode until reaching the minimum level. However, it is advisable to have enough solution in the recovery tank for better performance in the ECO-SYSTEM mode.

If the level on the recovery tank goes below the minimum level required for the ECO-SYSTEM function, all five led lights on the water metering unit will start flashing and the brushes will stop operating.

3



#### CHARGE BATTERY LEVEL INDICATOR AND DISPLAY

The charge level of the battery is displayed when the machine is switched on (100 – 90 – etc). When the battery charge level reaches 20, the number on the display starts blinking and the brush operation is disabled raising the plate, since a protection device is triggered to prevent the battery from getting damaged, however the suction and forward functions remain active.

At this point, the brush plate shall be raised and the floor shall be dried quickly.

Upon reaching level 10, the number on the display shall start blinking and the suction function will also be disabled, the forward function will be the only active function. Lift the squeegee, go to the tank drainage area and charge the batteries.

When 4 blinking dashes (----) appear on the display, the forward function will also be disabled as the battery reaches a minimum discharging threshold. Therefore, the machine must be pushed over to the tank drainage area and then pushed over to the battery charging area.

4

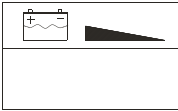

5



#### HOUR METER BUTTON

Hold down this button to display the operating hours of the machine.

6



#### HANDBRAKE ENGAGED RED INDICATOR LIGHT

When the LED is on and the buzzer buzzes, this means the handbrake is engaged.

Disengage the brake by means of the lever before starting to move the machine.

7

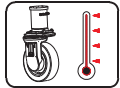

#### RED WARNING LIGHT: FORWARD GEAR MOTOR TEMPERATURE

If the temperature on the gear motor casing exceeds 75 – 85 °C, the red warning light will come on and the gear motor will stop operating, emitting a buzzing warning.

8



#### GREEN WARNING LIGHT: DRIVE ALARM

It shows any anomalies present on the motor's drive board.

On normal use the warning light flashes once every 5 seconds. If it flashes in a different way, it does mean that there is a problem with the drive system. The number of blinks indicates the type of fault (see troubleshooting table).

9



#### DETERGENT PERCENTAGE ADJUSTMENT POTENTIOMETER

By turning the potentiometer, the percentage of detergent in the solution being conveyed to the brushes can be increased or decreased.

10



#### WARNING SYMBOLS

The symbol on the left advises to use the instruction manual at all times for any information regarding the machine, whereas the symbol on the right forbids the use of water on the instrument panel as there are electrical parts.

11

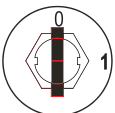

#### KEY-OPERATED SWITCH

The ignition sequence will start by rotating the key-operated switch clockwise (position 1); a series of information will appear on the display in successive order. **THE BUTTONS ON THE INSTRUMENT PANEL AND THE DRIVE CONTROLS SHOULD NEVER BE TOUCHED DURING THIS SEQUENCE.** The charge level of the battery will appear on the display at the end of the sequence, e.g. 100 - 90 - 80 etc. The machine is ready to be used only at this point.

12



#### TRANSPARENT INDICATOR LIGHT: DIPPED HEADLIGHTS

Indicator on when lights are on.

13



#### EMERGENCY SWITCH

To stop the machine in case of an emergency and stop all functions, press the button.

To reset everything, pull the button up.

14

**LIGHT AND HORN SWITCH**

By turning clockwise, the lights (position, dipped, full beam) come on. When pressed, the horn sounds.

15

**FULL-BEAM INDICATOR LIGHT**

Indicator on when lights are on.

16

**SPEED SELECTOR**

By pressing the button towards the "hare" symbol, the machine moves forward and in reverse at normal speed.

By pressing the button towards the "tortoise" symbol, the machine moves forward and in reverse at half speed.

This speed can be used in very dirty environments and allows using a lot of solution at low speed.

17

**DETERGENT DOSING SYSTEM GREEN INDICATOR LIGHT**

When the indicator light is on, this indicates the detergent dosing system is on.

18

ON

**LEVER SWITCH**

By pushing the lever towards the ON or OFF position, the detergent dosing system is turned on or off.

OFF

19

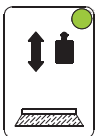
**BRUSH BUTTON**

Press this button to enable the brush function; a green led light will come on and the brush plate will descend. The brushes will start rotating when the forward pedal is pressed. When the forwards pedal is released, the brushes will rotate for other 3 seconds before stopping. In case of prolonged halt, after 1 min the brush plate will automatically rise. When the machine is in motion with lowered brushes, by pressing the brush button the brushes will stop rotating and the brush plate will rise. The electrovalve and the solution pump are also connected to the brush function and allow the user to automatically open or shut the flow of the solution while the brush is rotating. This function cannot be activated if there is not solution in the tank. In this case by pressing the button, the five led lights on the solution metering unit will start flashing and the brush function will not be enabled. When this occurs, make sure to fill the tank. This function will be automatically deactivated in case there is no solution in the tank. When this occurs, the five led lights on the solution metering pump will start flashing and the brushes function will be deactivated.

20

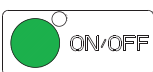
**GREEN ON/OFF BUTTON**

This button enables the operator to use all the functions of the machine. Press the button once to lower the brush plate and the squeegee, the led lights on this button and on the brush and suction fan buttons will come on. Push the drive pedal to start rotating the brushes and the solution metering pump.

The vacuum motor will also turn on. The quantity of water used will equal to the quantity stored after the last use.

Press this button again to stop the operation of the brushes and the brush plate will lift from the floor.

The squeegee will also lift from the floor with a preset delay to allow the operator to dry the entire floor.

If this button is pressed when the tank is empty, the five led lights on the solution metering unit will start flashing and the brush function will not be enabled, but only the squeegee. When this occurs, make sure to fill the tank.

## BRAKE PEDAL

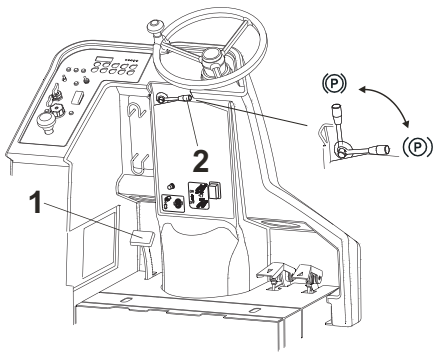

### SERVICE BRAKE

The machine is fitted with a service brake that operates on both the rear wheels. By pushing the pedal pos.1, the brake gets inserted.

### PARKING BRAKE

The machine is fitted with a parking and emergency brake that operates on both the rear wheels. To lock the machine, push the brake pedal pos.1 down, turn the lever pos.2 counter-clockwise to its maximum stroke and then release it.

Push the pedal pos.1 and turn the lever pos.2 clockwise to release the brake.

**ATTENTION:** to lock the machine by inserting the service brake, the acoustic signal is activated.

## BRAKE PEDAL ADJUSTMENT

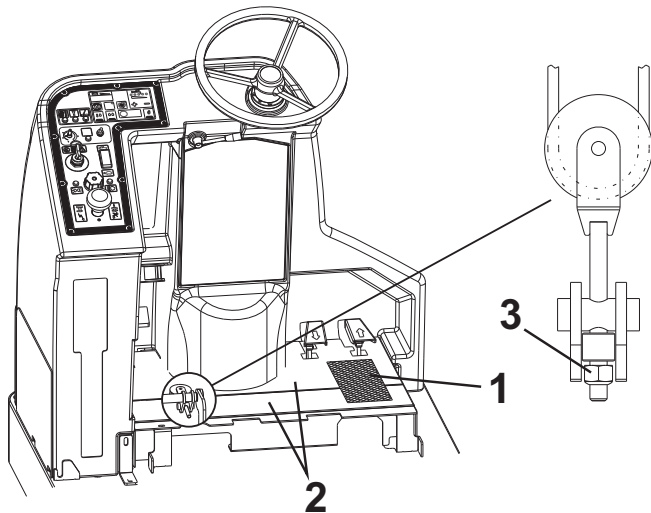

To adjust the brake, proceed as follows:

- Turn off the machine, ensuring that it is positioned on a flat surface, and remove the power source;
- Remove the mat pos.1 and the two footrests pos.2;
- Unscrew the nut pos.3 and push down on the brake pedal a couple of times. Adjust the brake so that it starts to work before reaching the middle of the pedal stroke;
- Try braking while the machine is moving;
- As a final check, raise the machine and turn the wheel by hand to check that it turns freely and that the brake shoes aren't touching the wheel;
- If everything is working correctly, reassemble the parts;

## BRUSHES REPLACEMENT/ ROTATION

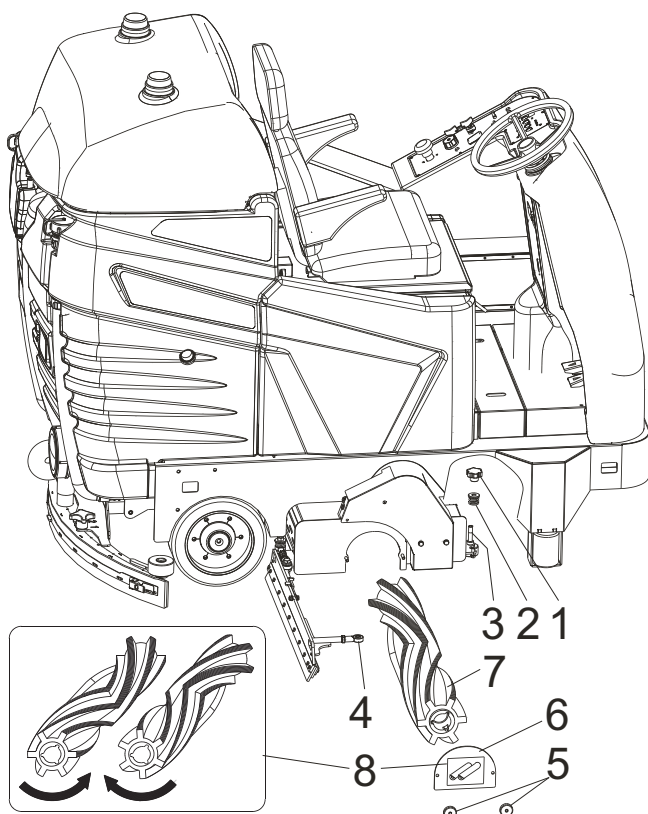

Follow the instructions below to replace or rotate the brushes:

- Switch the machine off on a flat surface with the lifted brush plate and remove the key;
- Insert the brake;
- Unloose the handwheel pos.1, remove the spring pos.2 from the pin pos.3;
- Remove the splashguard joint pos.4 from the pin pos.3 and rotate the splashguard backward;
- Remove the handwheels pos.5 and the hub pos.6;
- Remove the brush pos.7 from the hub located on the left side of the roller plate and replace it with a new one: then remount everything following the instructions on the contrary.

**ATTENTION – when remounting the brush, follow the assembly phase as indicate in the label pos.8.**

- To mount the left brush, follow the same instructions;
- Insert the key;
- To activate the brushes, make sure there is water in the tank;
- **ATTENTION: – The brushes must always be replaced together, bearing in mind that the minimum diameter is 115 mm.**

**ATTENTION – After 40-50 working hours we recommend inverting the brushes position to even out the wear so they can last longer**  
Eliminate wires or any plastic threads or any other material which are tangled with the brush.



## MOUNTING THE SQUEEGEE

Follow the instructions below to mount the squeegee to the machine:

- Disable the suction function to keep the squeegee support in up position and facilitate assembling procedures;
- Park the machine on a flat surface, insert the brake, switch it off and remove the key;
- Fit in the squeegee pos.6 into the squeegee support pos. 7 centring the knobs pos.5 into the corresponding slits on the support pos.7;
- Once the squeegee is fitted completely, secure the knobs pos.5;
- Connect the squeegee hose from the curved side pos.2 into the special hole located in the tank pos.1 and press down until it fits into place completely;
- Mount the other end of the hose, from the roll-up side pos.3 into the squeegee in the cuff pos.4;
- Connect the hose in the special locking springs pos.8.

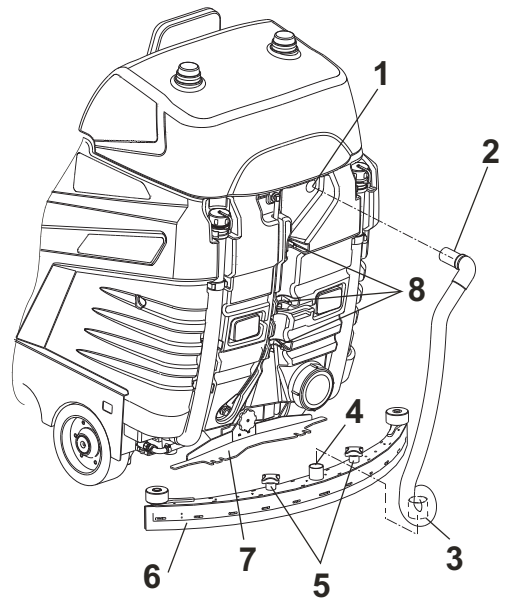

## ADJUSTING THE SQUEEGEE

There are 3 types of adjustments that can be carried out on the squeegee:

- **Inclination adjustment**, with knob position 2.

It adjusts the inclination of the squeegee in order to have a constant pressure over the entire length of the blade pos.1. Turn the knob counter-clockwise if there is too much pressure on the outer points and little pressure on the central area.

Turn the knob clockwise if there is little pressure on the outer points and too much pressure on the central area. To make the adjustment lower the squeegee, turn on the suction fan and drive forward slowly. Examine the pressure distribution on the blade and if necessary correct the inclination as described above;

- **Pressure adjustment**, using the knob in position 3.

This allows for optimal pressure on the blade pos.1 which can be adjusted for each type of floor and for each type of blade. For rough floors or uneven floors, increase the pressure by turning the knob pos.3 clockwise.

For smooth floors, lower the pressure by turning the knob counter-clockwise;

- **Max. pressure limit** by means of the knob in position 4.

Allows setting max. pressure to be applied to the squeegee blades. To be adjusted when thinner blades are fitted or when the second suction unit is fitted.

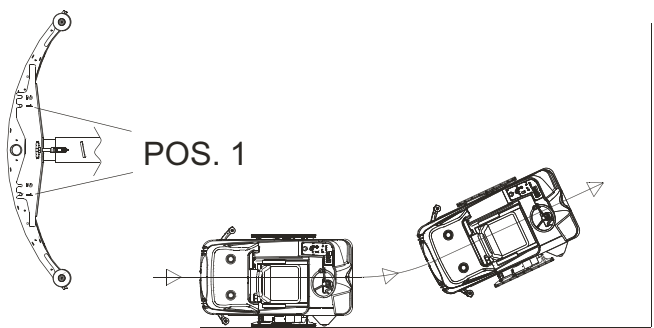
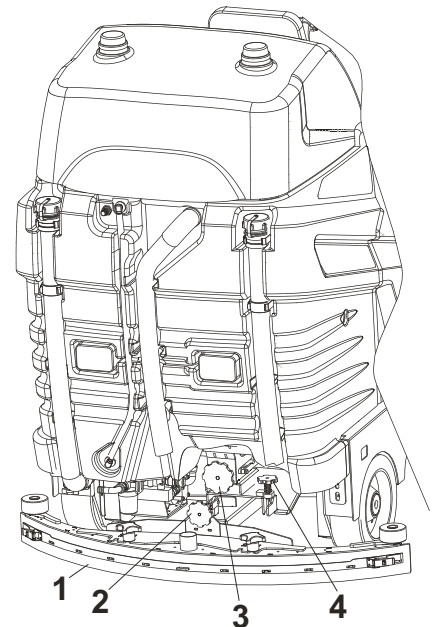

### POS. 1: NORMAL SITUATION

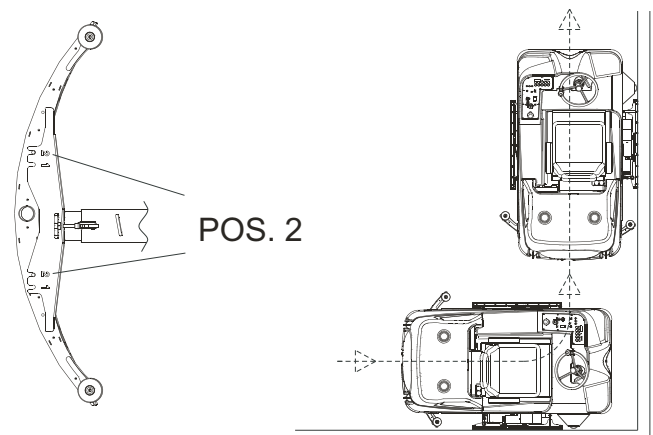

**POS. 2: ENABLE YOU TO WORK NEXT TO THE WALLS AND TO TURN LEFT OF 90° NEAR THE CORNER**



## FILLING THE DETERGENT SOLUTION TANK

The solution tank can only be filled with clean water when the detergent dosing system is used, or with a mix of water and detergent suited to the type of floor and to the conditions of dirt to be washed and a product suitable for reducing foam.

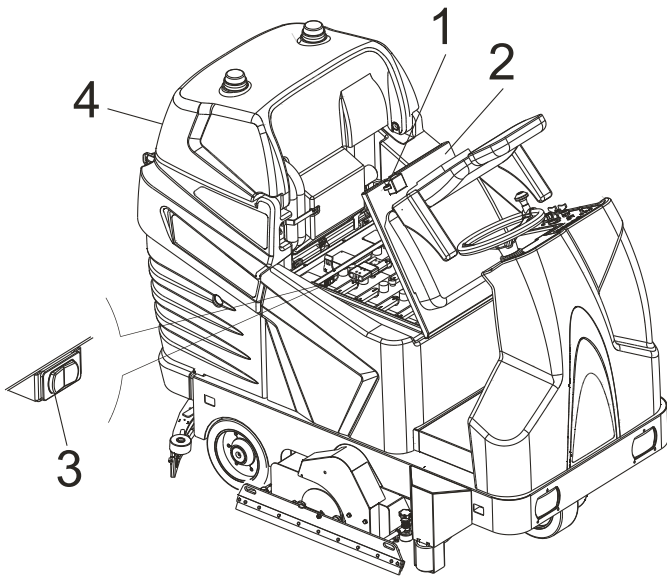

- Stop the machine on a flat floor area, turn off the ignition key and engage the brake;
- Open the seat hood pos.2 by releasing the safety catch pos.1;
- Rotating the key-operated switch clockwise (pos.1) and open the tank lid pos.4 by means of the button pos.3 which controls an electric actuator.

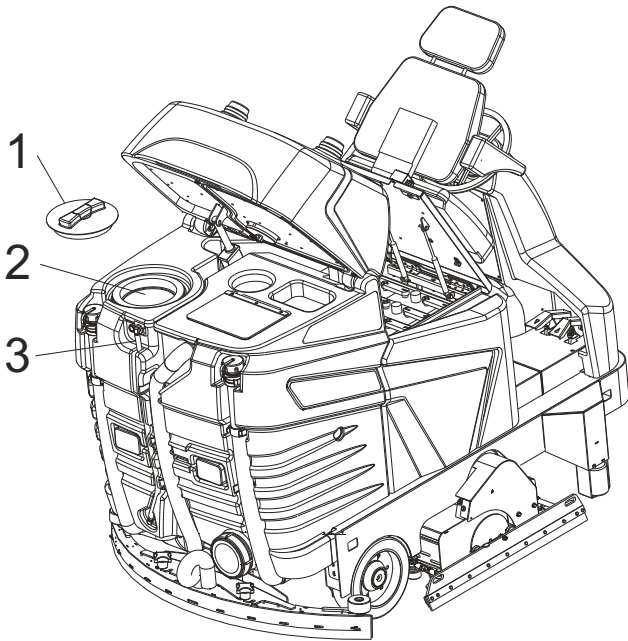

- Loosen the cap pos.1 and remove it;
- Only fill the tank with clean water, with a temperature below 40°C, in the event of the detergent dosing system being used;
- In the event of the detergent dosing device not being used:
- Pour the detergent solution into the tank directly. Look at the instructions on the package to determine how much detergent solution to use, how to mix the solution and what safety precautions to take before using the product. Make sure to use low-foaming liquid detergents or appropriate products to cut-down foam.
- After pouring the detergent solution, fill the tank with water. Make use the water used to fill the tank does not exceed 40°C.

### **WARNING: DO NOT POUR INFLAMMABLE LIQUIDS INTO THE TANK;**

- After filling the tank, place the device pos.1. The level of the water or of the solution in the tank can be seen through the level pipe pos.3.
- The machine cannot be used with the tank lid raised; lower it using the appropriate button before use.

## ADJUSTING THE QUANTITY OF SOLUTION ON THE BRUSHES (WATER + DETERGENT)

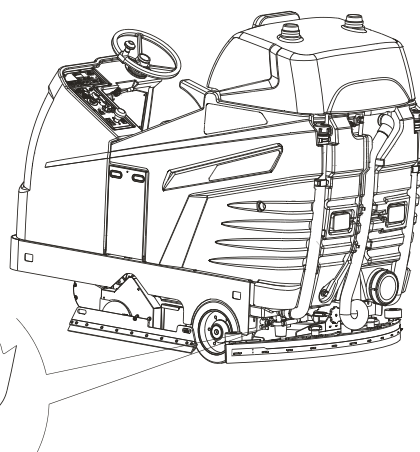
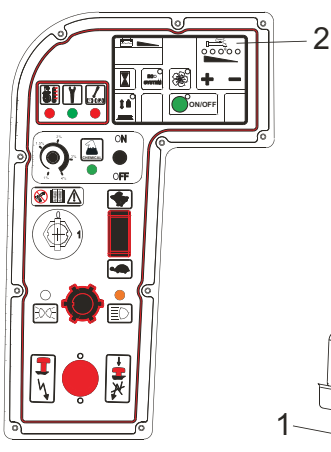

The max. quantity of the solution on the brushes can be adjusted by using the + and - keys (pos. 2) located on the board panel. Our scrubber-dryer features a solution electronic dosing system which – for being proportional to the machine speed constantly allows for the correct flow of solution on the brush – thus minimizing any waste. In fact, by decreasing the machine speed, the solution flow decreases accordingly. On the contrary, by increasing the machine speed, the flow will increase till reaching the preset maximum level at maximum speed. The above-mentioned dosing device can be activated also with the machine in ECO-SYSTEM mode. Make sure that the valve (pos. 1) located beneath the machine is open before operating the machine.

## SPLASH GUARD LIFTING FOR PRE-WASHING

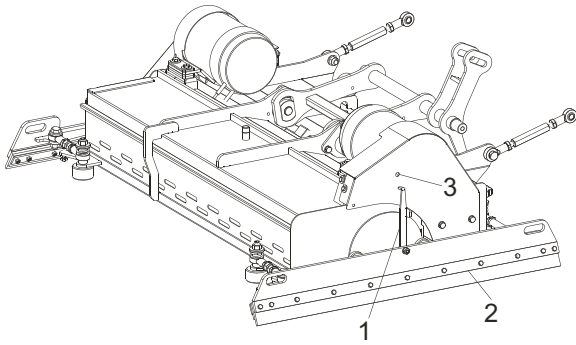

A pre-washing operation is highly advisable when using the machine for particularly dirty surfaces, as to allow the chemical product present in the detergent solution to remove the dirt more efficiently. Once pre-washing is over, clean the surface by activating the brush function. Do not use the squeegee to gather the solution. During this operation it is advisable to lift the machine splashguard as to allow the detergent solution to spread smoothly over the surface.

After a few minutes, wash the surface one more time after lowering the splashguard and activating the vacuum function as to dry the floor.

To lift the splashguard (right & left), please refer to the following instructions:

- Rotate the lever pos.1 upwards;
- Lift the splashguard pos.2 manually by pulling it upwards;
- Insert the lever pos.1 into the hole pos.3. In this way, the splashguard will remain raised from the ground.

Once pre-washing is over, release the lever pos.1 from the hole, thus letting the splashguard pos.2 lower and bending the lever.

## DETERGENT DOSING DEVICE

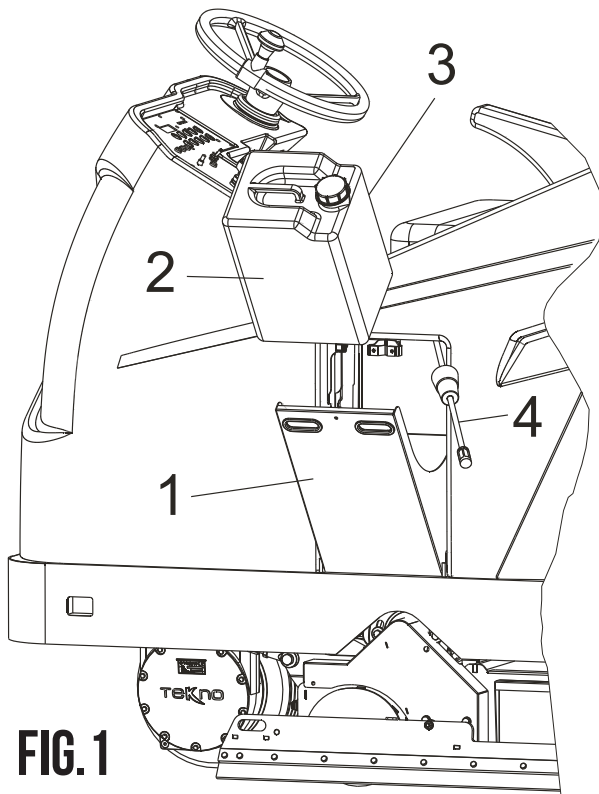

**FIG. 1**

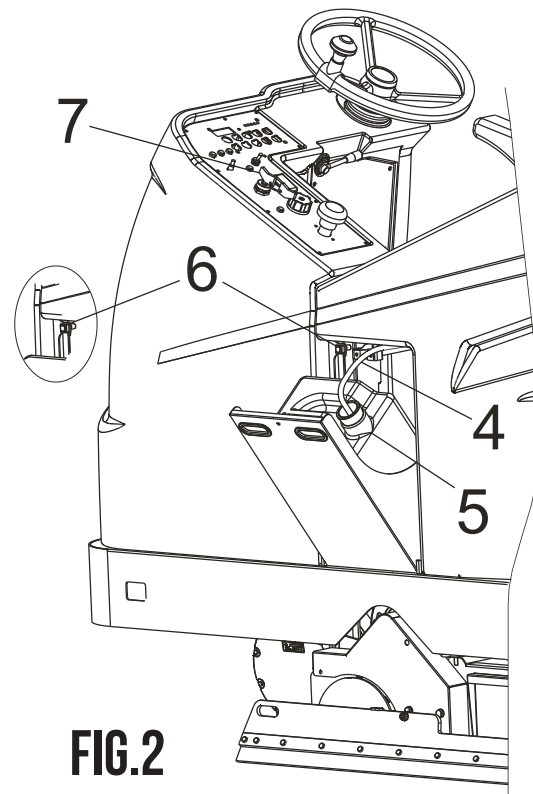

**FIG. 2**

To use the detergent dosing device, the detergent can must be fitted in the compartment provided on board the machine.

To do this, proceed as follows:

- Open the compartment pos.1;
- Take out the pipe pos.4 so it does not hinder can fitting;
- Fit the can pos.2 as indicated in FIG.1. While performing this operation, do not remove the cap pos.3 of the can to prevent detergent coming out. Use low-foam liquid detergents or use a foam reducing product. Do not use inflammable liquids.

For the percentages of detergent to be used and for safety precautions to be taken, see the instructions on the pack.

- Once the can has been fitted, remove the cap pos.3 and insert the pipe pos.4, making sure the filter reaches the bottom so as to suction up all the detergent in the can.
- Block the pipe pos.4 by means of the cone pos.5 inserting it in the can with a slight pressure FIG.2.

## DETERGENT DOSING SYSTEM WASHING

Once the washing operation has terminated, to keep the system in good working order and prevent scale, the system is best washed as follows:

- Remove the detergent can and insert another one filled only with water;
- Make sure there is some water in the clean water tank;
- Fit the detergent suction pipe pos.4 and block it in position by means of the cone pos.5;
- With the machine stopped, turn the ignition key pos.7 to POS.1 and press the red key pos.6.

The metering pump will start to operate and suck up the water from the can and begin washing the entire dosing system. At the same time, the water pump will also begin operating, washing the pipes, the solenoid valve and the pump.

## DETERGENT DOSING SYSTEM CONTROLS

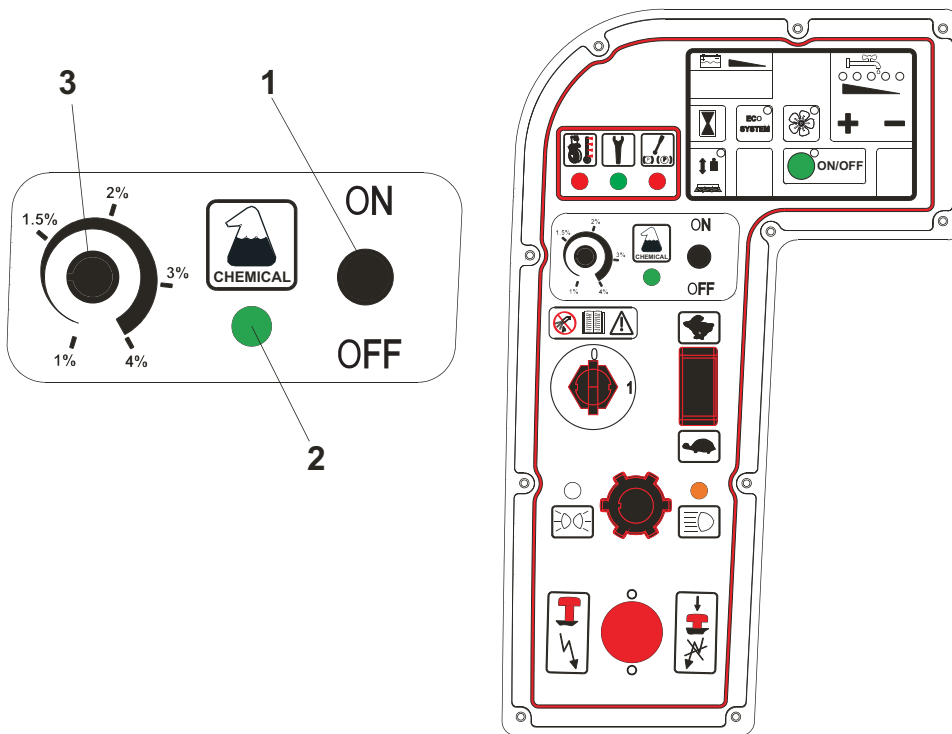

The detergent dosing device is switched on by moving the lever switch pos.1 to ON.

At the same time as the pump, the green indicator light pos.2 also comes on to indicate the system is ON.

The detergent pump operates when the water pump is on.

The percentage of detergent can be metered by means of the potentiometer pos.3.

For the percentages to be used, follow the instructions on the pack.

Our scrubber-dryer features an electronic solution dosing device proportionate to the speed of the machine, so the exact quantity of solution can always be obtained on the brushes, thus avoiding waste.

This operating principle is also applied to the detergent dosing system.

## BRUSH AND WATER PUMP CUT-OUT SWITCH

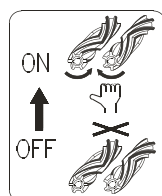
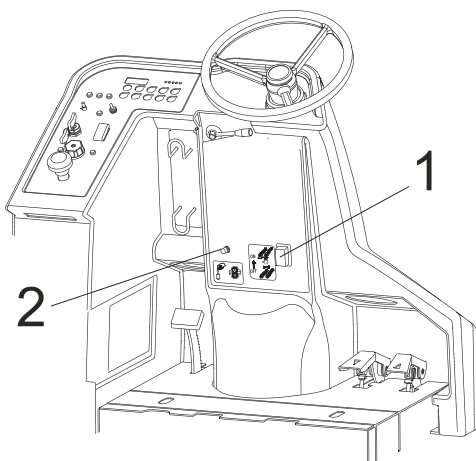

If during the washing phase, there is over-absorption of the brushes, the cut-out switch intervenes and stops the brushes.

To re-start the brushes, engage the cut-out switch again by lifting the switch pos.1. Check the brush motors if this would happen further.

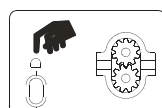

If during the washing phase, there is over-absorption of the water pump, the cut-out switch intervenes and stops the pump.

To re-start the brushes, engage the cut-out switch again by pressing the switch pos.2. Check the pump if this would happen further.

# USING THE MACHINE

Our scrubber-dryers must be operated by properly trained authorised staff.

Scrubber-dryers that do not operate properly must be taken out of service immediately.

## CHECK BEFORE USE

Make sure to check the following before using the machine:

- Make sure the battery connector is plugged-in;
- Make sure the key is fitted correctly;
- Check the battery charge level.

The charge level of the battery will appear in the instrument panel when the machine is on. Charge the batteries if the battery charging level is low.

- Make sure the brushes or discs are in good condition and mounted correctly;
- Make sure the splash guards that are mounted into the brush plate are in good condition;
- Make sure the rubber wheels on the squeegee are in good condition and set properly;

## OPERATION

- Release the parking brake using the lever;
- Turn the key to position 1;
- Push the ON/OFF button. A green led will turn on and all the functions will be activated. At this point, both the brush tray and the squeegee will lower. The brush motors and the vacuum motor will switch by pressing the advance pedal. The quantity of detergent solution will be the one which has been kept in memory since the last time the machine has been used. In case you wish to adjust it, work on the + and – buttons - on the control panel;
- The brush function can be enabled individually using this button on the instrument panel. The brush plate will lower onto the floor by means of the actuator; however, the brushes will not start rotating until the drive command is activated.

Press the button again to disable the function and the pilot light will start flashing giving enough time to lift the brush plate and switch off the motors before turning off itself.

If during the washing operation, there is an over-absorption of the brushes, the cut-out switch intervenes and stops the brushes. By pressing the advance pedal, the brush bottom starts flashing, the writing E1 appears on the control board and after 5 sec. the plate will lift. To start again: turn the key in pos 0 and then in pos. 1; activate the cut-out switch again;

- It is possible to turn on the suction fan using the special button in the instrumental panel. The squeegee will lower by means of the actuator; however, the suction fan will only come on when the drive pedal is pressed. Press the button again to disable the function and the pilot light will start flashing; the squeegee will remain on the floor for a preset period of time and it will then lift and switch off the suction fan as well as the pilot light on the instrument panel. The pilot light will also start to flash if the machine goes in reverse drive to indicate that the squeegee is being raised from the floor. The machine is also fitted with a float that shuts off the vacuum motor when the water level in the recovery tank is too high. If this occurs, the pilot light on the suction motor button will start to flash and switch off the suction fan. The pilot light will continue to flash until the tank is emptied, or until the machine switches off.

Drain the tank into the special drainage areas. By pushing the vacuum button the automatical ECO-SYSTEM cleaning device will be activated. This will keep filters and conduits clean during the use of the ECO-SYSTEM. Every 2 minutes a valve will be activated and you will hear a mechanical noise;

- Set the desired maximum solution quantity using + and – keys. The led lights may start flashing if there is a leakage of the solution while operating or while attempting to enable the brush function without solution in the tank. When this occurs, make sure to fill the tank;
- Move the detergent dosing system switch to ON. The green indicator light will come on to indicate the system is operating. The metering pump will operate in conjunction with the water pump with the same switch-on and off procedures. The percentage of detergent will also remain unchanged when the water flow is increased or decreased by means of the keys + and –. The detergent flow is also proportionate to the machine speed, just like the water flow;
- Set the percentage of detergent according to the instructions on the pack;
- When starting the washing operation, make sure to lubricate the cutting edge of the splashguard blades. As soon as the brush plate lowers with the detergent solution opened, slowly move the machine forwards and backwards for a few meters in order get the splashguard rubber wet. This operation will protect the cutting edge of the splashguard blades and increase its life;
- To avoid damaging the floors, when you start working, be very careful not to halt the machine over the same floor area while the brushes continue to operate;
- The brushes will stop automatically after 3 seconds when the forward pedal is released. Stopping the pump and closing the electrovalve, the flow of the solution will be shut off. When resuming the drive operation, the brushes will start and the solution will automatically start to flow;
- In case of prolonged idle time, the brush plate will lift after 1 minute and switch off the function. The suction fan will also switch off but the function will remain active (pilot light on) and the squeegee will not lift automatically for safety reasons. The suction fan will resume operation when the drive pedal is pressed again.

**IMPORTANT:** make sure to press this button to lift the squeegee;

- If the squeegee leaves wet lines on the floor during the washing operation, it means that there are pieces trapped beneath the rear rubber wheels of the squeegee. Lift the squeegee and remove the trapped pieces. Use a cloth to wipe off the rear rubber wheels if the pieces cannot be removed manually. In any case, it is always advisable to sweep the floors before washing;
- Once the solution is used up, the machine can continue its washing operation using the ECO SYSTEM function that can be enabled by pressing the button located in the instrument panel, this will enable the machine to re-use the water from the recovery tank as it is duly filtered by the special tank filter.

The ECO-SYSTEM function can also be enabled before consuming the entire detergent solution;

in this case, the operation will only be allowed if there is enough solution in the recovery tank. The function will not be enabled if the level is too low (the pilot light will not come on when pressing the button). If this occurs, continue to wash the floor using the detergent solution until the function can be enabled. However, if the ECO SYSTEM is started when there is still some solution left in the clean water tank, the operation can be deactivated at any time and it is possible to resume washing using the solution from this tank. When using the ECO SYSTEM mode, the water is also distributed according to the speed of the machine, therefore the maximum quantity of water will flow when the machine reaches its maximum speed. The detergent dosing system will also remain on in ECO-SYSTEM mode. Decide whether to switch it off or reduce the percentage inasmuch as the solution in the recovery tank already contains detergent;

- It is advisable to run a pre-wash operation before washing very filthy floor surfaces, as described on page 24;
- When completing the washing operation turn off the wash functions using the green ON/OFF button, which will switch off the brush function as well as the vacuum function after a preset delay and lift the squeegee. The 2 functions can be switched off individually using the relevant buttons for each function. In this case, the pilot light on the green ON/OFF button will remain active and must be switched off by pressing the button.

# MAINTENANCE

SERVICING YOUR SCRUBBER-DRYER REGULARLY AND PERIODICALLY WILL ENSURE BETTER PERFORMANCE AND MORE DURABILITY. THE FOLLOWING PAGES CONTAIN INFORMATION THAT WILL HELP YOU PLAN THE MAINTENANCE AND CARE FOR THE MACHINE NEEDS.

**WARNING!:** DO NOT PERFORM ANY MAINTENANCE ON THE MACHINE OR ANY OF ITS COMPONENTS WITHOUT TURNING OFF THE MACHINE AND UNPLUGGING THE BATTERY CONNECTOR.

**WARNING!:** DO NOT TAMPER WITH ANY SAFETY DEVICE.

THESE DEVICES CAN ONLY BE REMOVED WHEN PERFORMING MAINTENANCE BY AN AUTHORISED ASSISTANCE CENTRE (AAC).



## DRAINING AND CLEANING THE RECOVERY TANK

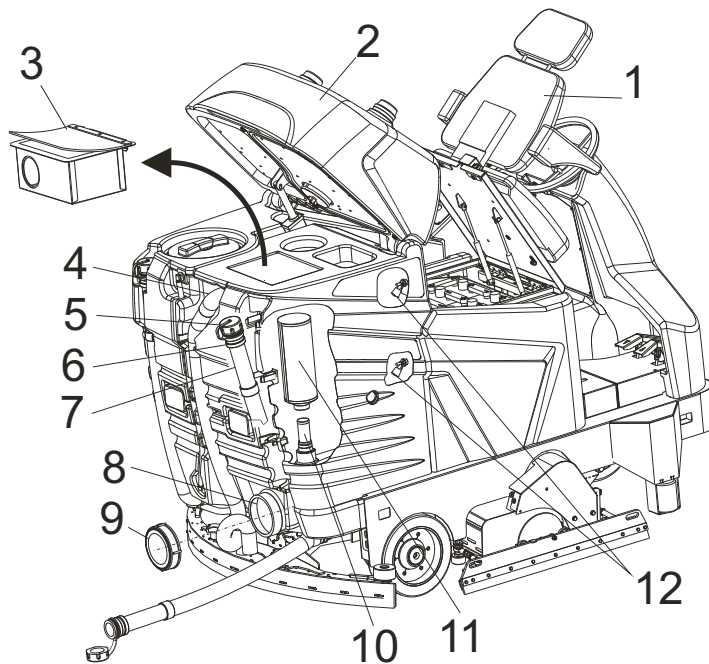

The recovery tank must be drained and cleaned after each washing operation.

In order to drain and wash the tank proceed as follows:

- Turn off the washing function using the ON/OFF button and go to the tank drainage area;
- Turn off the machine, remove the key and put on the brake;
- Open the hood of the seat pos.1 by releasing the special safety hook;
- Open the tank lid (pos.2) using the dedicated switch;
- Remove the safety filter for bigger debris pos.3 by holding it from its upper part and pulling it out of the tank. Empty the filter in an appropriate dirt container.

Wash the filter with water and remove the pieces which have got stuck through the meshes of the net, if there are any.

Remove the drain pipe from the dirty water tank pos.6 and while keeping the pipe vertically pos.5 open the lid by rotating it counterclockwise as indicated by the arrow. Part of the pipe is flexible pos.7 and therefore it can be squeezed to limit the water flow. Once opened, lay the pipe on the ground;

- After draining the tank, make sure to clean it thoroughly using water. If necessary, for cleaning use the hatch pos.8 removing the cap pos.9;
- Wash the ECO-SYSTEM filter pos.11 using water throughout the filter, paying attention not to damage it.

After each working day, carefully remove the filter and wash it inside in order to remove possible encrustations.

Before doing it, wash the area surrounding the filter. Unscrew the filter anti-clockwise.

Do not remove the safety filter pos.10 placed on the connection in which the filter is screwed in. To clean it, wash it with water;

- Wash the level sensors pos.12. Do not direct the water flow directly onto the sensors as not to damage them. If necessary, clean them by using a tissue in order to remove the material which might have got stuck in them (metallic debris) and could thus prevent the floating device from closing properly;
- After completing the cleaning procedures, remount the ECO-SYSTEM filter pos.11, put the cap back on the dirty water drain pipe and rotate it clockwise, then place the pipe back into its housing in the tank;
- The suction pipe on the squeegee pos.4 shall be washed periodically, in order to prevent encrustation formation inside the pipe.



## CLEANING INSTRUCTIONS ECO-SYSTEM

At the end of each working day take the machine to the tank draining area.

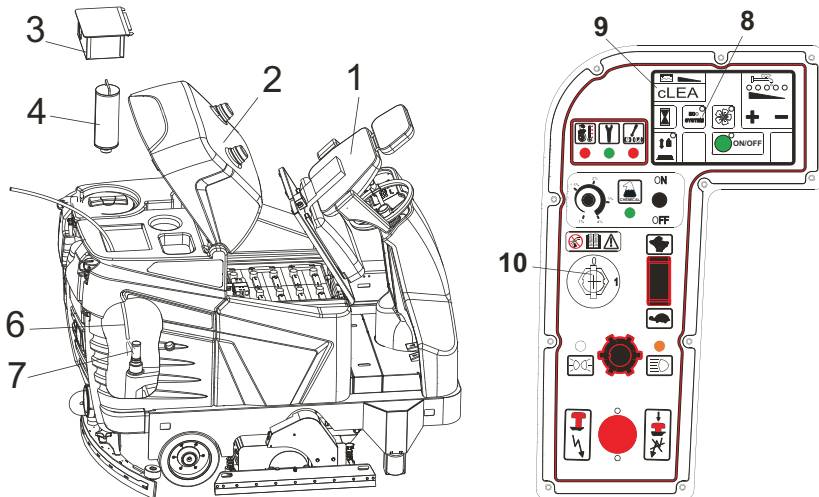

- Open the seat hood pos.1, by releasing the safety catch;
- Open the tank cover pos.2 by means of the key provided;
- Remove the basket pos.3;
- Empty and wash the recovery tank;
- Remove and wash carefully the ECO-SYSTEM filter pos.4;
- At this point start the ECO-SYSTEM clearing cycle as follows:
  - With the machine turned off hold the ECO-SYSTEM button pos.8 turn the key pos.10 in pos.1. Hold the button till the word cLEA appears on the display pos.9;
  - At this point move to the rear of the machine;

- When the pump starts to operate, pour water using a pipe pos.6 onto the safety filter pos.7 (which must never be removed) so as to allow washing all the ECO-SYSTEM plant (pipes, solenoid valve, pump). The cleaning operation will last about 40 seconds. If this time is not enough, repeat the complete cycle.
- To restore the normal functions of the machine, turn off and on the key;  
REASSEMBLE THE ECO-SYSTEM FILTER.



## DRAINING AND CLEANING THE SOLUTION TANK

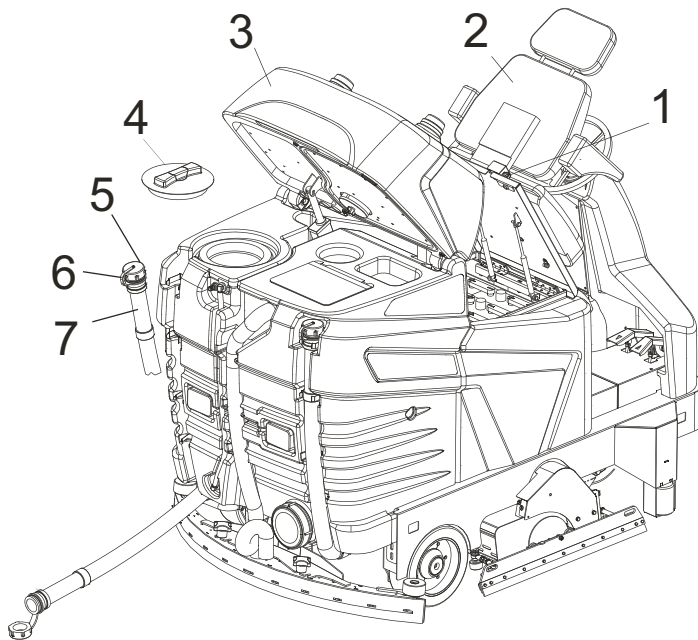

The solution tank must be drained after each washing operation. In order to drain and wash the tank proceed as follow:

- Turn off the washing function using the ON/OFF button and go to the tank drainage area;
- Turn off the machine, remove the key and put on the brake;
- Remove the drain pipe from the clean water tank pos.6 and while keeping the pipe vertically pos.5 open the lid by rotating it counterclockwise as indicated by the arrow. Part of the pipe is flexible pos.7 and therefore it can be squeezed to limit the water flow. Once opened, lay the pipe on the ground slowly;
- After completing the cleaning procedures, open the hood of the seat pos.2, by releasing the special safety hook pos.1;
- Open the solution tank pos.3 using the switch provided;
- Unscrew the cap pos.4 and remove it;
- Wash the tank with water by means of a rubber pipe, trying to direct the water flow towards the interior of the machine as to clean it completely;
- Once completing the cleaning procedures, close the cap pos.4, as well as the dirty solution tank pos.3, and the hood of the seat pos.2 and place the drain pipe pos.6 with its cap pos.5 into its housing.



## CHECKING BRUSHES OR ABRASIVE DISCS

- Check the condition of the brushes and replaced them if they are worn out;
  - Check the wear of the brushes: the minimum diameter shall not be less than 115 millimeters;
  - Check that there are not any wires, plastic threads or any other material which are tangled with the brush.
- Every 40 – 50 hours make sure to switch the front brush with the rear brush to even out the wear so they can last longer.



## CLEANING THE DETERGENT SOLUTION FILTER

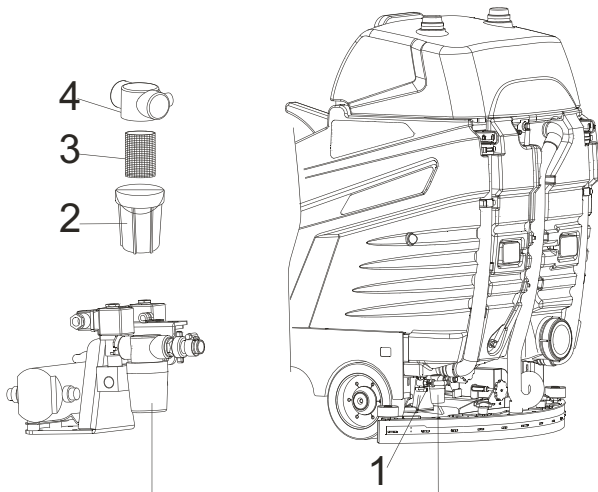

The machine is fitted with a filter on the pipe that comes from the detergent solution tank. In theory, the solution located in this tank should not have any impurities as the buckets or containers used to fill the solution are supposed to be clean, in addition there is a filter in the mouth of the tank that filters the water. Follow the instructions below to clean the filter:

- Bring the machine into a stop position in a flat surface area and put on the brake;
- Turn off the machine and remove the key;
- Close the valve pos.1 and remove the transparent cup pos.2;
- Remove the protective screen pos.3 and clean it with water together with the cup;
- Put the cup pos.2 and the protective screen pos.3 on the fixed part of the filter pos.4; make sure the protective screen is fitted correctly into its housing inside the cup and into the support;
- Open the valve pos.1;



## CLEANING THE SQUEEGEE

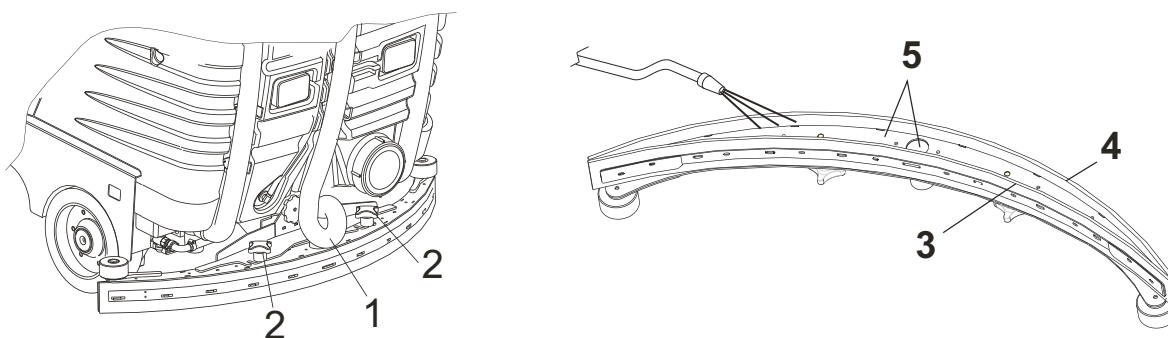

After completing the washing operation, clean the squeegee and make sure the blades are in good condition, then proceed as follows:

- Deactivate the suction function, in case it is active and lift the squeegee;
- Bring the machine into a stop position in a flat surface area;
- Turn the key to position 0 and put on the brake;
- Unscrew both screw knobs pos.2 and remove the squeegee vacuum pipe pos.1;
- Remove the squeegee, lay it on the ground facing up (as shown in the figure), wash it using water and for better vacuum flow, remove any pieces or incrustations from the lower part and from the mouth of the squeegee pos.5;
- Use a piece of cloth to wipe off the rear drying blade pos.4 and the front drying blade pos.3;
- Make sure the blades are in good condition and rotate them if necessary in order to have a new edge in contact with the floor.



## REPLACING SQUEEGEE BLADES

The squeegee is fitted with two drying blades, a rear and a front blade, as specified in the previous paragraph. Each blade has 4 edges that can be used and rotated 4 times before being replaced, unless one of the edges is torn. For better drying performance, make sure the edge of the rear blade is not worn out. If the blade is worn out, rotate it or replace it.

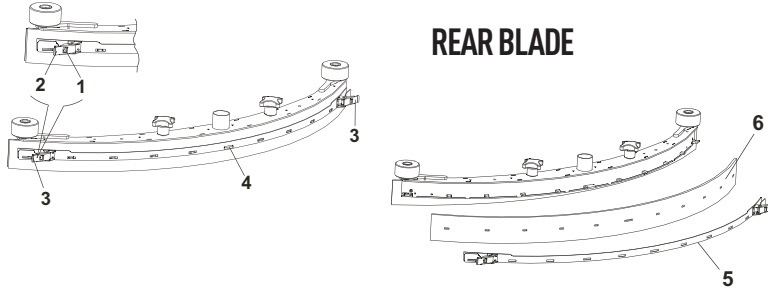

Follow the instructions below to rotate or replace the rear blade:

- Remove the squeegee from the machine;
- Remove the blade locking plate pos.5 by unlocking the retainer pos.3. This retainer is fitted with a safety device that keeps it from opening involuntarily. To release the retainer push the small lever pos.1 towards the outer part of the squeegee and then pull the big lever pos.2 towards the rear part of the squeegee;
- Remove the blade pos.6;
- Rotate the blade and mount it back so that a new edge is on the drying side;
- Position the plate on the squeegee fitting it first of all in the centre slot pos.4 and then fastening it at the ends;
- By remounting the blade pos.6 please pay attention that the blade lays on the floor regularly and uniform in its entire length.

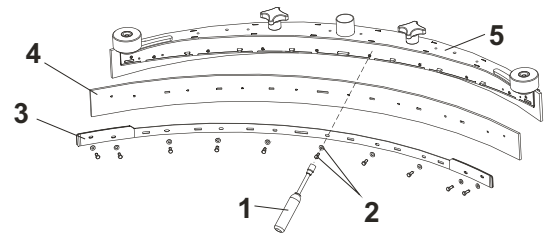

## FRONT BLADE

Follow the instructions below to replace the front blade:

- Remove the squeegee pos.5 from the machine;
- Use a 10 mm tubular nut driver pos.1 and remove the 6 screws and the respective washers pos.2;
- Remove the blade locking plate pos.3;
- Remove the blade pos.4;
- Rotate the blade and mount it back so that a new edge is on the drying side of the blade;
- Put the blade locking plate pos.3 back into place;
- Put the 10 screws back into place and the respective washers pos.2, paying attention that the blade pos.4 lays on the floor regularly and uniform and making sure not to tighten the screws excessively, causing the rubber blade to deform (swell).



## ROTATING OR REPLACING THE SPLASHGUARD BLADES

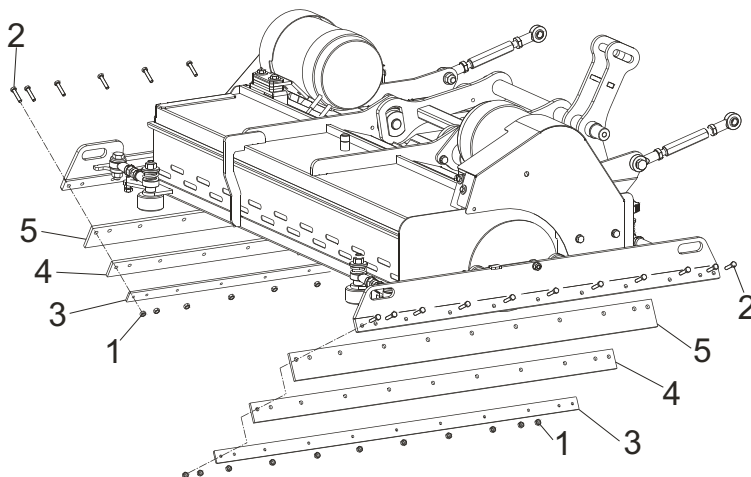

Follow the instructions below to rotate or replace the splashguard blades:

- Turn off the brushes function and lift the brush plate;
- Turn off the machine, remove the key and the battery connector and put on the brake
- Use a 10mm hex wrench and remove the nuts pos.1;
- Unscrew the screws pos.2;
- Remove the internal rubber locking plate pos.3 and the internal rubber pos.4;
- Remove the blade pos.5, rotate it 180° and put it back into place if the external edge is in good condition, otherwise replace it with a new one;
- Put the rubber, the internal plate and the sheet pos.3 back into place with the anti-slip surface on the rubber, using the screws.

Before fixing completely the screws, make sure that the rubber is equally distributed over the entire length. Fix the nuts.



## CLEANING THE DIRT CONTAINER

- With the lifted plate turn off the machine and remove the key, insert the brake;
- Lift slightly the dirt container (pos. 1) releasing it from its place and remove it;
- Empty the dirt container. Clean the dirt container with water and remove all pieces tangled in the net. Remount the container making sure it is well locked in its place.

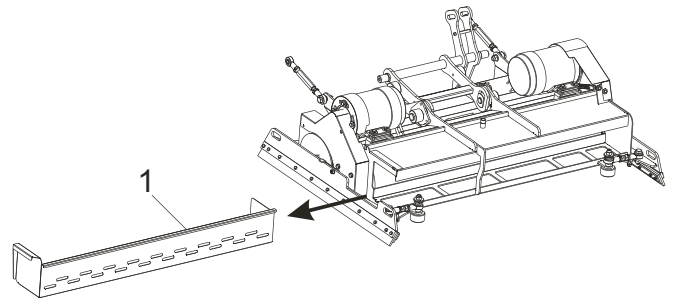

## CLEANING THE DETERGENT SOLUTION DISTRIBUTOR

The machine is fitted with a metering pump for clean water and a metering pump for detergent.

If the solution does not flow out of the tank properly, make sure the output distributor is not obstructed or clogged (pos. 1 and 2).

POS. 1: detergent output distributor;

POS. 2: clean water output distributor.

To check that proceed as follows:

- Bring the machine into a stop position in a flat surface area and put on the brake;
- Lower the brush plate by pressing the special button in the control board;
- With the lowered plate, turn off the machine and remove the key;
- Press the emergency button pos.5 so as to interrupt supply;
- Unscrew the cap manually pos.3 or pos.4;
- Use a thin piece of wire of approximately  $\varnothing$  2-3 mm and remove any incrustations from the pipe distributor pos.1 or pos.2;
- Mount the cap;
- Pull the emergency button upwards;
- Insert the key and turn it towards the ignition;
- After some seconds, the machine will lift automatically the plate and it will be ready to start working.

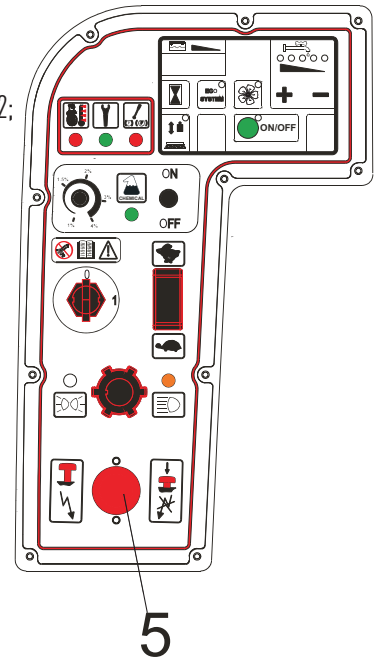
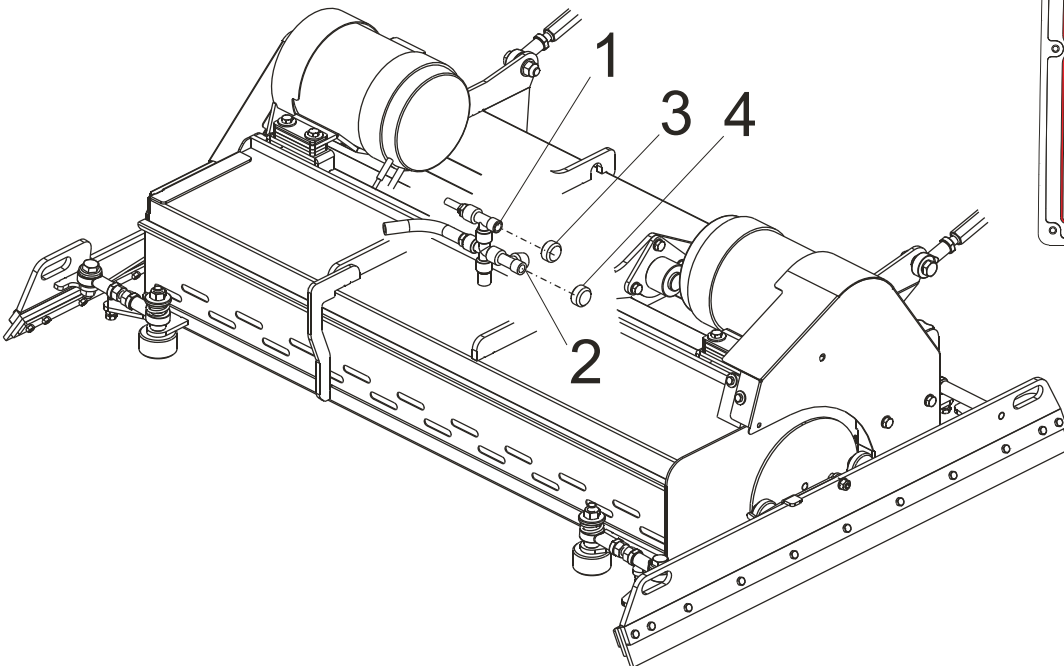



## CHECKING AND REPLACING FUSES

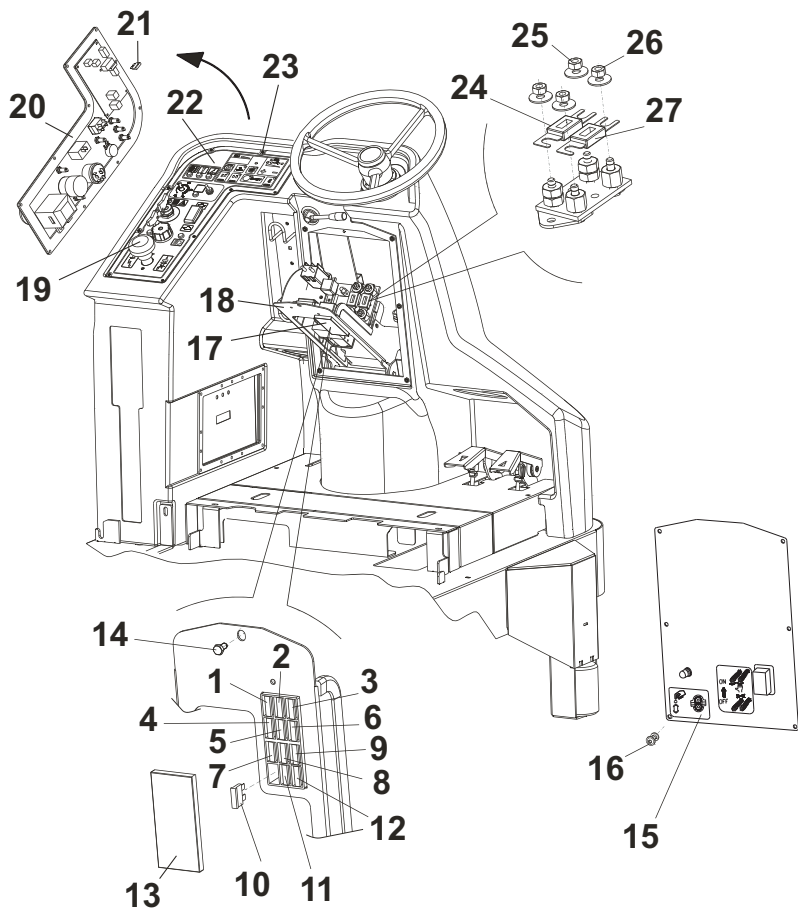

To check or replace the fuses on the switchboard proceed as follows:

- Bring the machine into a stop position in a flat surface area, turn the key in pos. 0 and put on the brake;
  - Press the emergency button pos.19;
  - Remove the 6 locking screws pos.16 from the fuse holder hood pos.15 and remove it;
  - To make fuse changing more accessible, remove the screw pos.14 and open the control panel box pos.18 as shown in the illustration;
  - In the electric plan there are different fuses and fuse holders that have the following functions:
  - There are 12 fuses located in the fuse holder pos.17 and they have the following functions and features
- POSITION 1: 30A fuse vacuum motor (STANDARD);
- POSITION 2: 5A fuse control board and battery charger protection;
- POSITION 3: 30A service supply protection fuse (transformers, function control board, etc);
- POSITION 4: 15A fuse pump protection;
- POSITION 5: 3A fuse flashing light protection;
- POSITION 6: 10A fuse for the protection of the 24V transformer 1 output (drive motor temperature indicator warning light, drive motor temperature alarm buzzer, reverse buzzer, drive system operation warning light, flashing lights);
- POSITION 7: 5A reverse light protection fuse;

POSITION 8: 10A fuse for the protection of the 24V transformer 2 output (all lights, horn, headlight warning lights, handbrake warning light, handbrake buzzer);

POSITION 9: 30A suction motor protection fuse;

POSITION 10: 3A lid actuator protection fuse;

POSITION 11: 3A drive motor cooling fan protection fuse;

POSITION 12: 3A battery-charger cooling fan protection fuse;

• Fuse pos.24: 80A fuse **BRUSH MOTORS PROTECTION**

ATTENTION: This fuse is used by the function card to control the correct absorption of brush motors (amperometric protection). It is possible that, although the motor reducers work with a correct absorption, error E1 appears on the display. In this case there is an oxidation of the fuse that gives a wrong reading.

Please proceed as follows:

- Unscrew the 2 nuts pos.25 that fix the fuse of 80A pos.24
- Clean the fuse holder and oil it with Vaseline
- Reassemble the nuts.

IMPORTANT: use exclusively the original spare fuse

• Fuse pos.27: 125 A fuse **PROTECTION OF THE DRIVE SYSTEM**. TO REPLACE IT PROCEED AS FOLLOWS:

- Remove the 2 nuts pos.26;
- Replace 125A fuse pos.27 with a fuse of equal amperage and with the same manufacturing characteristics;
- Reassemble the 2 nuts.

• Fuse pos.21: 20A fuse **CONTROL BOARD CARD PROTECTION**; TO CHECK OR REPLACE IT, PROCEEDS AS FOLLOWS:

- Use a 2.5 mm Allen wrench and remove the 10 clamping screws pos.23 from the instrument panel, including the respective nylon washers;
- Carefully turn the instrument panel pos.22, follow the arrows and make sure not to jerk it as it may damage the electrical system;
- Remove the 20A fuse pos.21, check it and replace it if necessary with a fuse of equal amperage;
- Put the instrument panel back into place pos.22;
- Put the washer and screws back into place pos.23 and close the panel using the special wrench, make sure to apply enough pressure on the seal beneath the panel pos.20;

Once the fuses are checked or replaced, put everything back together and bring the machine back to its operating condition.



## GREASING POINTS

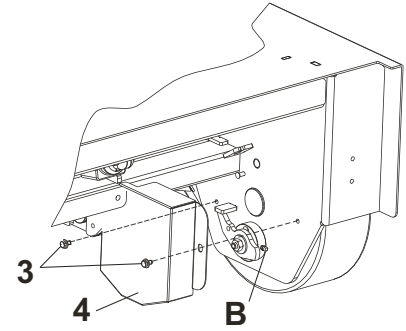
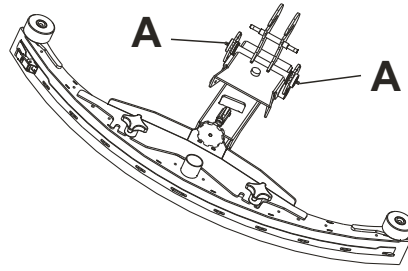
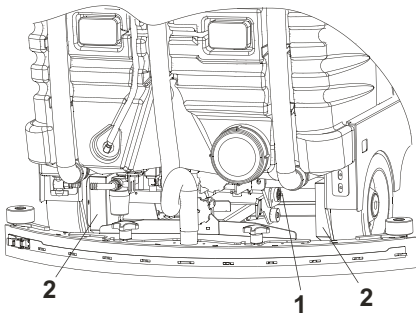

Every 100 hours, grease points A and B shown at points 1 and 2.

POINT 1: squeegee rotation pin; fill lubricators pos.A using a lubrication pump.

POINT 2: right and left wheel brake pin:

- Remove the 2 screws pos.3;
- Remove the protection guard pos.4;
- Using a lubrication pump, fill the lubricator pos.B.
- Fit everything back together again.

Repeat the operation on the brake pin of the left wheel.



## CHECKING OR REPLACING THE OIL OF THE DRIVE WHEEL REDUCER

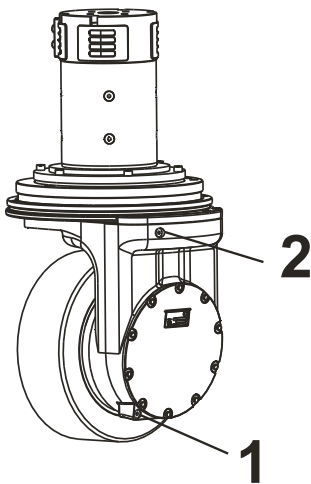

### OPERATIONS TO BE CARRIED OUT ONCE EVERY 500 WORKING HOURS AS TO CHECK THE OIL LEVEL OF THE DRIVE WHEEL REDUCER:

- 1) Check the oil level by removing the level/oil cap pos.2;
- 2) If necessary, fill up the wheel reducer with SYNTHETIC OR MINERAL OIL SAE 80W90 up to the level and then refit the cap pos.2.

### OPERATIONS TO BE CARRIED OUT ONCE EVERY 2000 WORKING HOURS AS TO REPLACE THE OIL OF THE DRIVE WHEEL REDUCER :

- 1) Unscrew and remove the level/oil filling cap pos.2;
  - 2) Fit a suitable basin for the oil gathering. Then, unscrew the drain plug pos.1 and remove it as to wait for the oil outflow;
  - 3) Remove any metallic waste which got stuck on the drain plug;
  - 4) Refit the drain plug pos.1 by means of a proper gasket;
- Fill up the reducer with SYNTHETIC OR MINERAL OIL SAE 80W90 up to the level and then refit the oil filling cap pos.2.



## CLEANING THE SUCTION FILTER

The machine is fitted with a stainless steel washable cartridge filter or – as optional – with a PU filter on the suction duct, which provides two functions:

- 1) To filter the air vacuumed by the squeegee, trapping dust before releasing it into the environment, without putting it back into the air;
- 2) To protect the suction motor against dust that may ruin moving mechanical parts, making them last longer

Follow the instructions below to clean the filter:

- Bring the machine into a stop position in a flat surface area and put on the brake;
- Open the cover pos.3, turn off the machine and remove the key;
- Unscrew the locking filter handwheel pos.1;
- Remove the filter pos.2 from its seat;
- Wash the filter with water and dry it using hot air, be careful not to damage it;
- Put the air filter back into place pos.2;
- Lower the locking filter handwheel pos.1;
- Turn the machine on and close the tank cover.

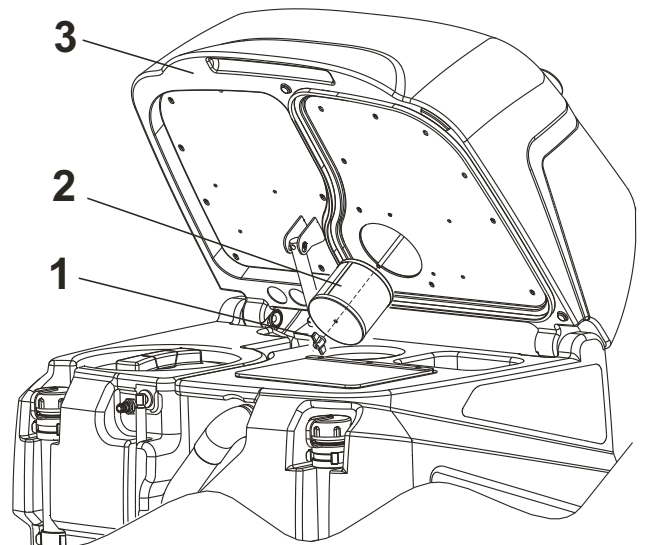



## CHECK THE SEAL ON THE COVER

The recovery tank cover seal ensures that a proper vacuum is created inside the tank and this provides a better suction performance on the squeegee. It is very important to keep the seal intact in order for the machine to work properly.

To clean and check the seal, proceed as follows:

- Open the cover pos.1;
- Use a piece of cloth to wipe off the seal pos.2 and make sure it is not broken or damaged;
- If the seal is damaged, remove it from the cover, mount a new seal and make sure to fit the seam of the seal into the rear position pos.3;
- Clean the area of the tank where the seal leans pos.4 when the cover is closed.

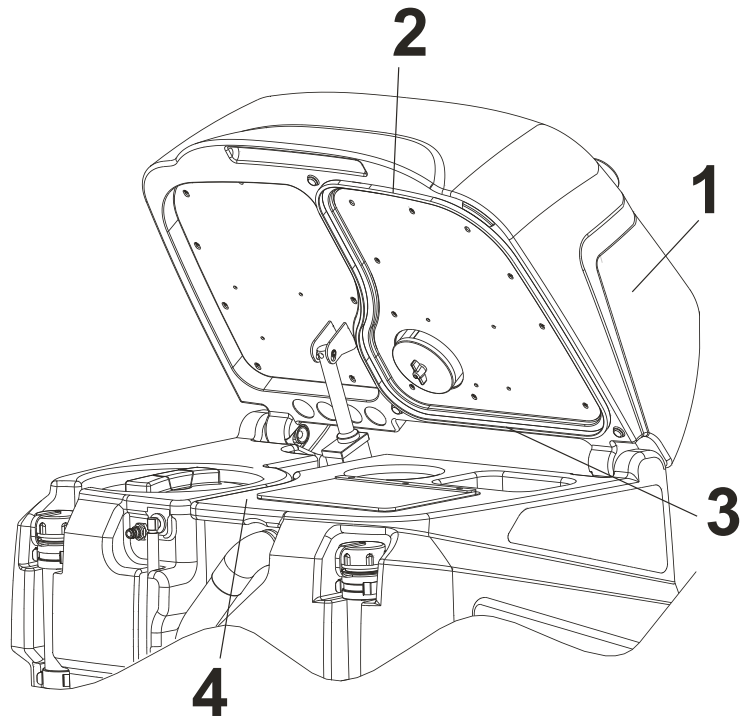

## RECHARGING BATTERIES

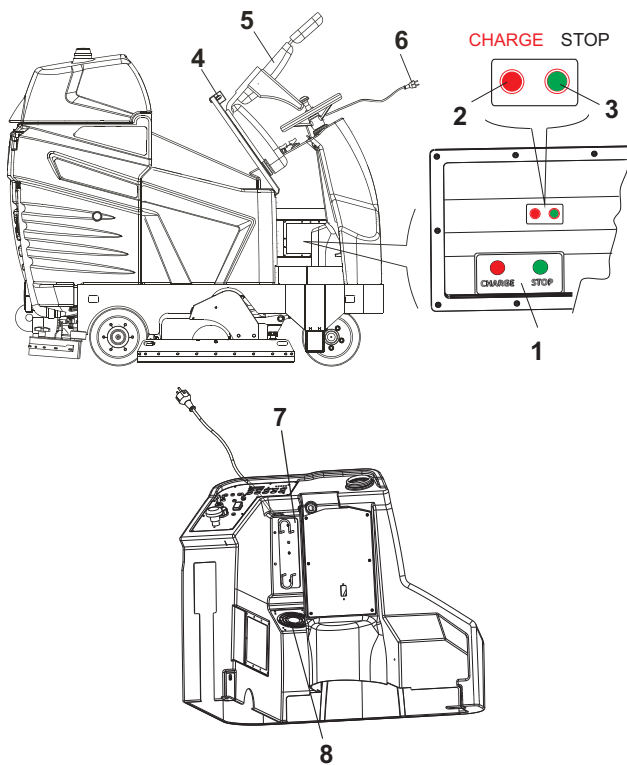

**WARNING! THE CHARGER IS PRESET FOR LEAD BATTERIES. TO MOUNT GEL OR AGM BATTERIES, BOTH THE STATUS LED AND THE CHARGER HAVE TO BE SET ACCORDING TO THE TYPE OF BATTERY WHICH IS TO BE USED. TO THIS AIM, PLEASE CONTACT EITHER A TECHNICIAN OR AN AUTHORIZED RETAILER.**

To charge the batteries follow the instructions below:

- Bring the machine into a flat surface area, turn it off and put on the brake;
  - Before charging the battery make sure to scrupulously follow the battery charger instruction manual provided with the machine;
  - The recharging of the battery is to take place in well-aired environments;
  - Open the hood of the seat pos.5 by releasing the locking device pos.4.
- The battery charger can run with a voltage range 230 VAC, for the use with different voltages it is advisable to use a proper charger;
- Unwind the cable from the cable reel pos.7 located on board the machine and connect the plug pos.6 into a standard electrical power socket. By inserting the socket, the red light led CHARGE pos.2 of the charger switches on;
  - By inserting the socket, the cooling fan pos.8 starts working.
- The fan works for about 13 hours;
- The label pos.1 indicates that the battery charger is charging (charge phase) when the red light led CHARGE pos.2 is on. When the green light led STOP pos.3 is on, it means that the charge phase is finished.

**WARNING: WHEN PLUGGING THE BATTERY CHARGER INTO THE ELECTRICAL SOCKET, THE MACHINE FUNCTIONS ARE AUTOMATICALLY DISABLED;**

- Before disconnecting the charger from the power socket, check that the green light led STOP pos.3 is on.

Once the charge is completed the plug can be disconnected from the electrical socket and rolled back into the cable reel

Once the battery is charged make sure to check the electrolyte level and if necessary fill it up only using distilled water;

- The gas released during the charging process can cause explosions if it comes into contact with flames or sparks;
- Battery acid should never come into contact with the eyes, skin or clothes, make sure to wear goggles, gloves and appropriate clothing;
- If it comes into contact with the eyes or skin, wash immediately with abundant water;
- Do not place metal objects on the batteries;
- Do not fill the batteries with sulphuric acid or other products.

# DIMENSIONAL TECHNICAL DRAWINGS

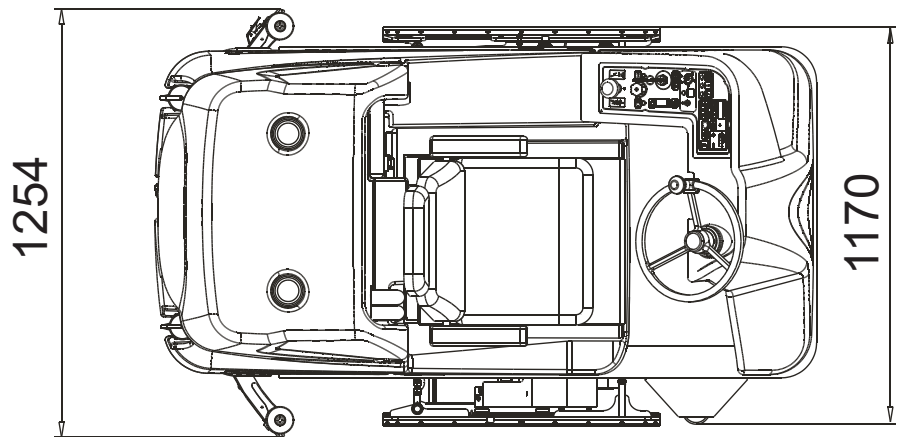
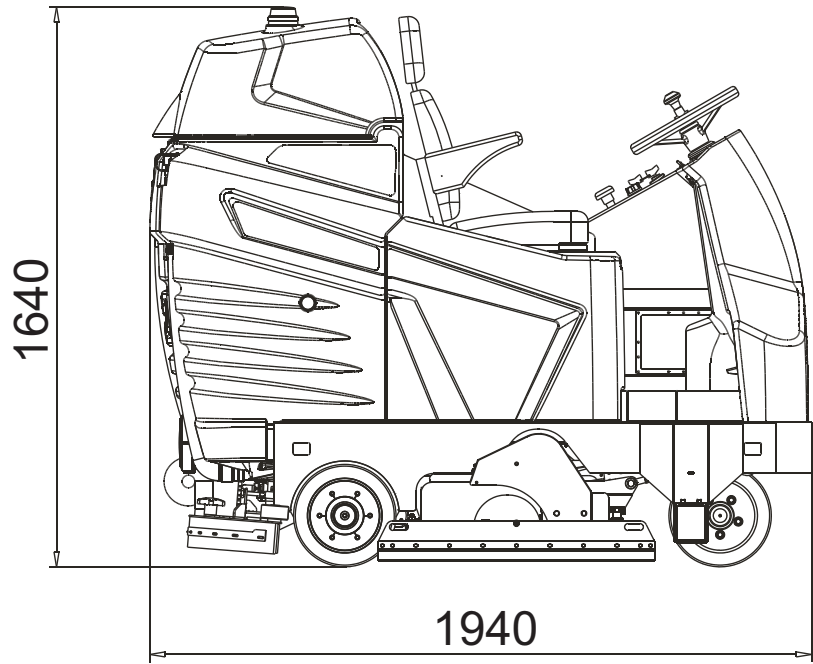
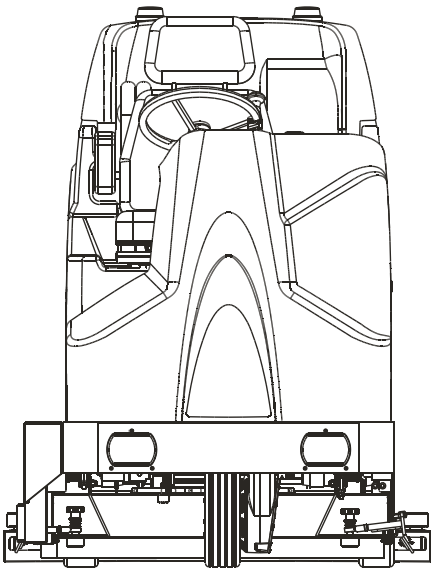

# TECHNICAL CHART

TECHNICAL SPECIFICATIONS		
<b>MAIN SPECIFICATIONS</b>	Cleaning path	1.100 mm
	Hourly performance	8.800 m <sup>2</sup> /h
	Solution tank capacity	220 L
	Recovery tank capacity	240 L
	Forward speed	0 - 8 km/h
	Maximum gradient	19 %
	Turning radius	1.125 mm
<b>DIMENSIONS AND WEIGHT</b>	Dimensions (without squeegee)	1.940 x 1.150 x 1.640 mm
	Width (with squeegee)	1.260 mm
	Weight	720 kg
	Weight (with type A batteries)	1.200 kg
	Weight (with type B batteries)	1.200 kg
	Packaging dimensions	2.270 x 1.360 x 1.770 mm
	Packaging weight	115 kg
	Packaging volume	5,46 m <sup>3</sup>
<b>BRUSHES</b>	Brush dimensions	Ø 180 - 980mm
	Pad size (only with pad holder)	/
	Brush motor	Gear motor: 36V - 950 W - 1700 RPM - IP 20
<b>TRACTION SYSTEM</b>	Traction type	Forward and reverse traction via front drive wheel, electronically controlled
	Traction motor	36V - 2600 W - IP 20 - 4060 RPM
	Front wheel RPM (machine unloaded)	160 RPM
<b>BATTERIES</b>	Batteries	1 x 36
	Battery tray dimensions	614 x 620 x 458 mm
<b>TYPE A BATTERIES</b>	Type	1 lead acid battery 36V 400A C5 with auto watering system
	Dimensions ea.	614 x 620 x 458 mm
	Weight (with acid) ea.	480 kg
	Autonomy (theoretical)	4 h
<b>TYPE B BATTERIES</b>	Type	1 gel battery 36V 350A C5
	Dimensions ea.	614 x 620 x 458 mm
	Weight (with acid) ea.	490 kg
	Autonomy (theoretical)	3 h 30 min

TECHNICAL SPECIFICATIONS		
<b>BATTERY CHARGER</b>	Model	230V (±15%) 50/60 Hz
	Settings	Calibrated for lead acid, AGM/gel, or gel Sonnenschein batteries
<b>SOLUTION FLOW</b>	Solution control	24V 150W - 1/5A
	Flow rate	Min level: 6 L/min, max level 13 L/min
<b>VACUUM SYSTEM</b>	Vacuum motor	3 stage, 36V 600W 17A
	Water pick up	1.800 mm/H <sub>2</sub> O
	Standard filter	Stainless steel mesh
<b>WHEELS</b>	Front wheel	Ø 300 x 100 mm - solid rubber, super elastic, non-marking and oil resistant Hub made of steel coated in polyurethane
	Rear wheels	Ø 300 x 100 mm - solid rubber, super elastic, non-marking and oil resistant. Hub made of nylon coated in polyurethane
	Brakes	Drum brakes on rear wheels
<b>SOUND LEVEL (UNI EN ISO 11201)</b>	Noise emission value LpA	69.8 dB (A)
	Uncertainty KpA	2.4 dB (A)
<b>VIBRATION LEVEL</b>	Whole-body vibration level aW	0.47 m/s <sup>2</sup>
	Uncertainty K	-
<b>TEMPERATURE RATING</b>	Storage temperature	+5 / +40 °C
	Operating temperature	+5 / +40 °C

# OPTIONAL

## RIGHT SIDE SWEEPING BRUSH EXTENDIBLE

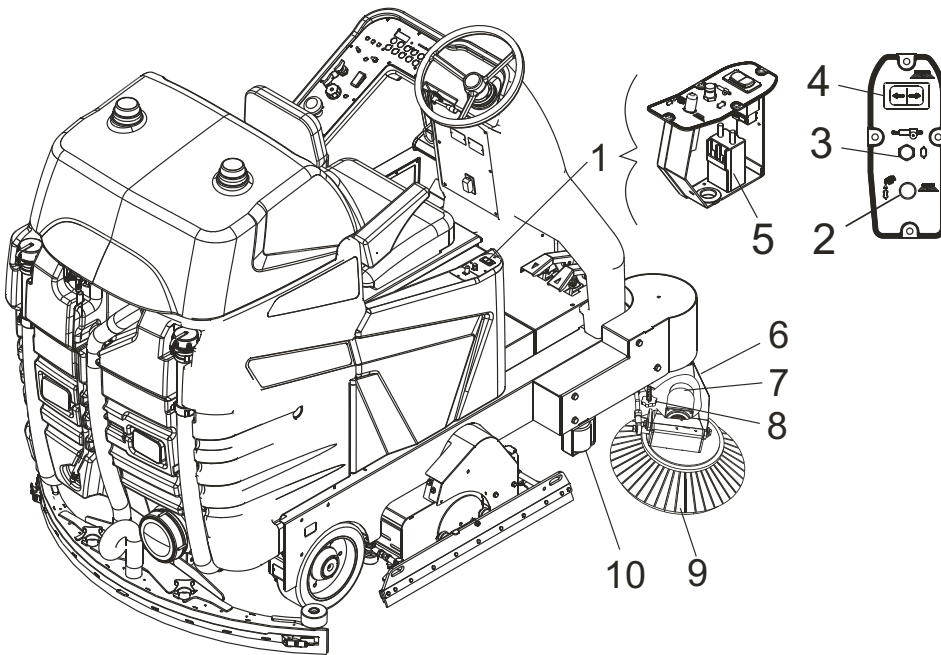

1. SIDE BRUSH CONTROL PANEL
2. RESET FUSE – When the brush motor exceeds the established current draw for a few minutes, the fuse trips and stops the motor. Wait 1-2 minutes, press the fuse button and the brush will start working again.
3. FUSE - 5A glass fuse to protect the brush lifting actuator.
4. BRUSH CONTROL BUTTON – By pressing the right side of the button, the brush drops and comes out of the side. By pressing on the left side of the button, the brush returns in and lifts up.  
NOTE – the side brush only turns when the main brushes are operating.
5. REMOTE-CONTROL SWITCH
6. BRUSH PLATE
7. GEAR MOTOR
8. BRUSH PRESSURE ADJUSTMENT HANDWHEEL
9. BRUSH
10. BUFFER ROLLER

## REPLACING AND ADJUSTING THE RIGHT-SIDE SWEEPING BRUSH

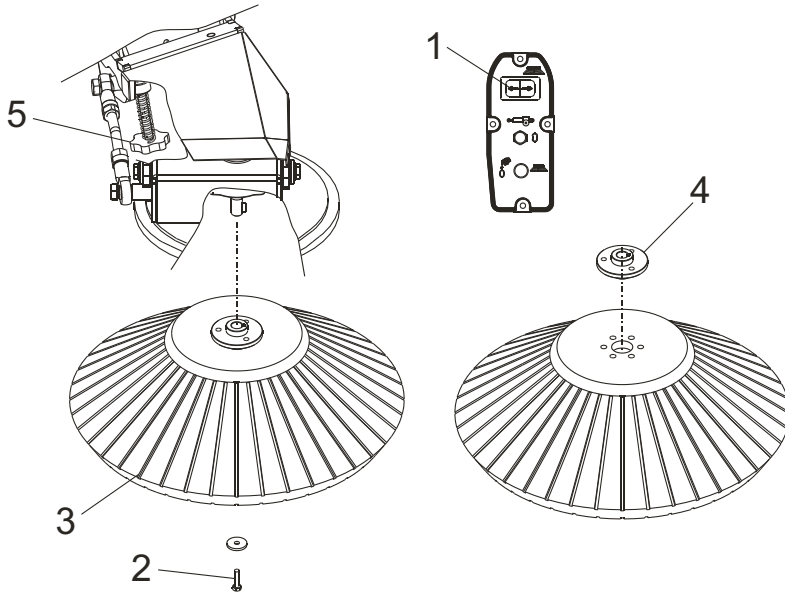

To replace the brush, proceed as follows:

- Position the brush in idle condition by means of the control pos.1;
- Stop the machine on a flat section of floor, engage the parking brake, switch off the machine and interrupt the power supply;
- Using a specific wrench, loosen the screw pos.2, remove the brush pos.3 from the gear motor shaft;
- Remove the flange pos.4 from the old brush and fit it on the new one;
- Fit everything back together again.

The pressure of the brush on the floor is adjusted by means of the handwheel pos.5:

- By tightening the handwheel, the pressure drops;
- By loosening the handwheel the pressure of the brush on the floor increases.

## RIGHT SIDE SCRUBBING BRUSH EXTENDIBLE

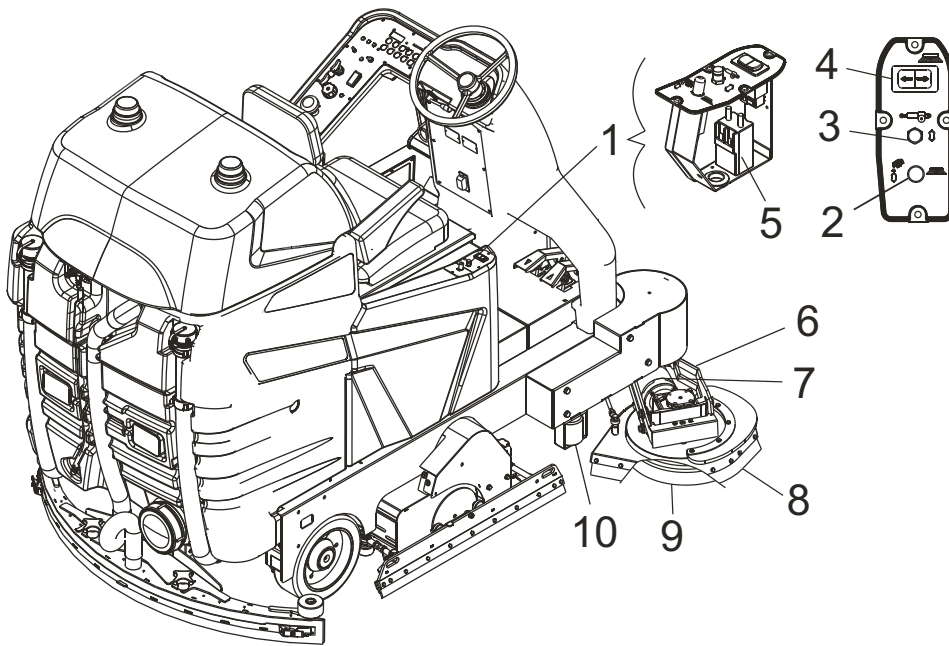

1. SIDE BRUSH CONTROL PANEL
2. RESET FUSE – When the brush motor exceeds the established current draw for a few minutes, the fuse trips and stops the motor. Wait 1-2 minutes, press the fuse button and the brush will start working again.
3. FUSE - 5 A glass fuse to protect the brush lifting actuator.
4. BRUSH CONTROL BUTTON – By pressing the right side of the button, the brush drops and comes out of the side. By pressing on the left side of the button, the brush returns in and lifts up. NOTE – the side brush only turns when the main brushes are operating.
5. REMOTE-CONTROL SWITCH
6. BRUSH PLATE
7. MOTOR REDUCER
8. SPLASHGUARD
9. BRUSH
10. BUFFER ROLLER

## FASTENING AND RELEASING THE BRUSH OR THE ABRASIVE DISC

To automatically fasten the side brush or the disc pad holder with abrasive disc, proceed as follows:

- Make sure there is water in the solution tank;
- Stop the machine on a flat piece of floor and engage the parking brake;
- Insert the key pos.3;
- By pressing the right side of the button pos.1 the side brush plate pos.2 will come out and drop;
- Remove the key pos.3;
- Using your hand, lift the splashguard pos.5 and the brush plate pos.2 and position the brush or the disc pad holder pos.6 underneath the brush plate;
- Turn the key pos.3 to position 1 and wait for the machine to perform the entire ignition procedure until the battery charge level appears on the screen;
- Lower the brush plate pos.4 by means of the button pos.7 on the panel.

NOTE – the side brush only turns when the main brushes are operating;

- Press the forward movement pedal pos.8 lightly. The brush motors will start to turn and the machine will start moving slowly. Move forward for a short distance and then reverse the direction of movement by pressing the reverse pedal pos.9 and move backwards slowly until the brush has fastened on. If necessary, repeat the operation. During fastening on operations, we suggest setting the detergent solution flow at 0 (all the LEDs pos. 10 off) to avoid any waste;

To manually fasten the side brush or the disc pad holder with abrasive disc, operate as follows:

- Stop the machine on a flat piece of floor with the brush plate pos.2 raised and engage the parking brake and remove the key;
- Manually position the brush pos.11 underneath the plate and turn it anti-clockwise.

To release the side brush or the disc pad holder with abrasive disc, proceed as follows:

- Stop the machine on a flat piece of floor and engage the parking brake;
- Raise the brush plate by pressing on the left side of the button pos.1 and remove the key pos.3;
- Manually take the brush and turn it clockwise.

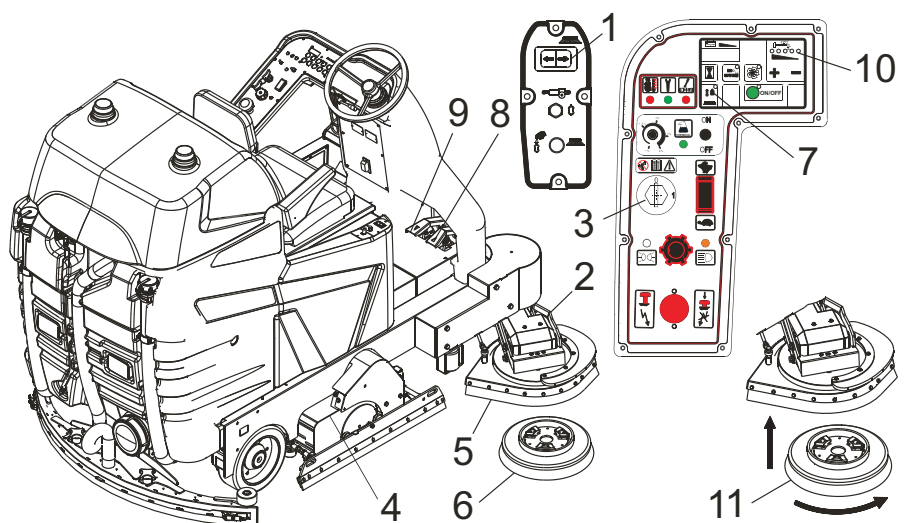

## CLEANING THE SOLUTION DOSER CONNECTOR

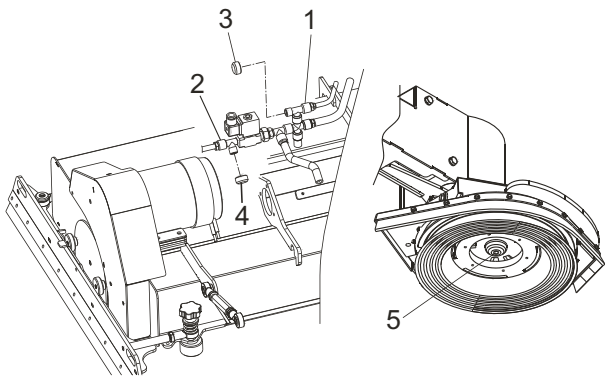

The machine features a pump that regulates the flow of clean water and a metering pump that regulates the flow of detergent. In case of any flow blockage, make sure the nozzles indicated in pos. 1 and 2 are not blocked.

POS. 1: detergent flow nozzle;

POS. 2: clean water or solution flow nozzle.

To do this, proceed as follows:

- Stop the machine on a flat section of floor and engage the parking brake;
- Keep the side brush plate raised;
- Lower the central brush plate by pressing the relevant key on the panel;
- In this situation, switch off and remove the key; remove the battery connector;

NOZZLE POS.1: unscrew the cap pos.3 manually; with a piece of metal wire ( $\varnothing$  2-3 mm) remove any scale from the nozzle pos.1 and fit the cap back on.

NOZZLE POS.2: unscrew the cap pos.4 manually; blow compressed air inside the water pipe through the hole on the hub pos.5 until this comes out of the nozzle pos.2. To make the operation easier, if necessary remove the brush; at the end tit the cap back on.

To start the machine again:

- Fit the battery connector, insert the key and turn it in the direction of ignition;
- After a few moments, the machine will automatically raise the central brush plate and will be ready to operate again.

## REPLACING THE SPLASHGUARD BLADES

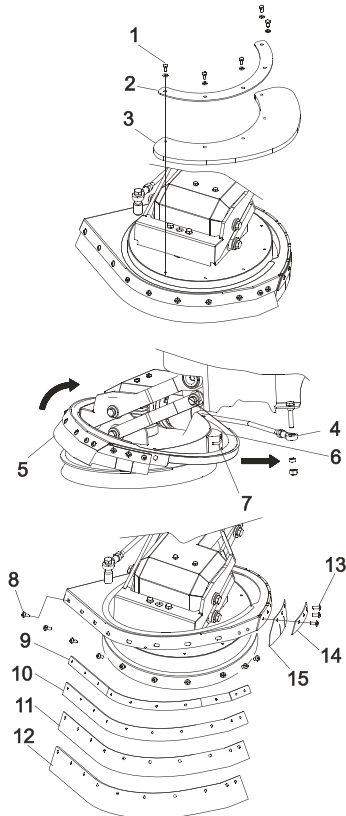

Position the machine on a flat section of floor with the side brush plate lowered and engage the parking brake; remove the battery connector

- Remove the screws and the relevant washers pos.1;
- Remove the plate pos.2 and the bumper pos.3.

- Release the tie-rod pos.4;
- Remove the splashguard pos.5 from its seat;

Lift in at the opposite point with respect to block position pos.6 just enough for it to come out, by pushing in the direction of the arrow, from the guide slit pos.7.

- Remove the screws pos.8, remove the plate pos.9, remove the nylon reinforcement pos.10 and then the inner blade pos.11 and the external blade pos.12;
- Replace the blades pos.11-12);
- Fit everything back together again making sure that the blades protrusion is uniform along its entire length with respect to the support.

- 
- Remove the screws pos.13, remove the plate pos.14, remove the blade pos.15;
  - Replace the blade pos.15 and fit everything back together.

## CONTROL AND REPLACEMENT OF THE FUSE ON THE PANEL

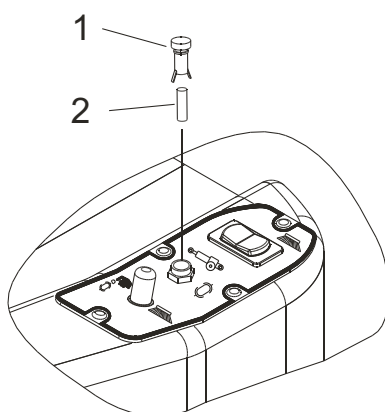

The side brush control panel features a 5 A glass fuse to protect the actuator which operates the brush.

To check and replace the fuse proceed as follows:

- Disconnect the battery connector;
- Turn the fuse carrier cover pos.1 by 1/4 of a turn anticlockwise and remove it; the fuse is connected to the cover;
- Check and if necessary replace the fuse pos.2, removing it from the cover, with another having the same ampere and features;
- Fit the new fuse in the cover and then fit everything back together again;
- Reconnect the connector to the battery.

## RIGHT AND LEFT SIDE SWEEPING BRUSH NO EXTENDIBLE

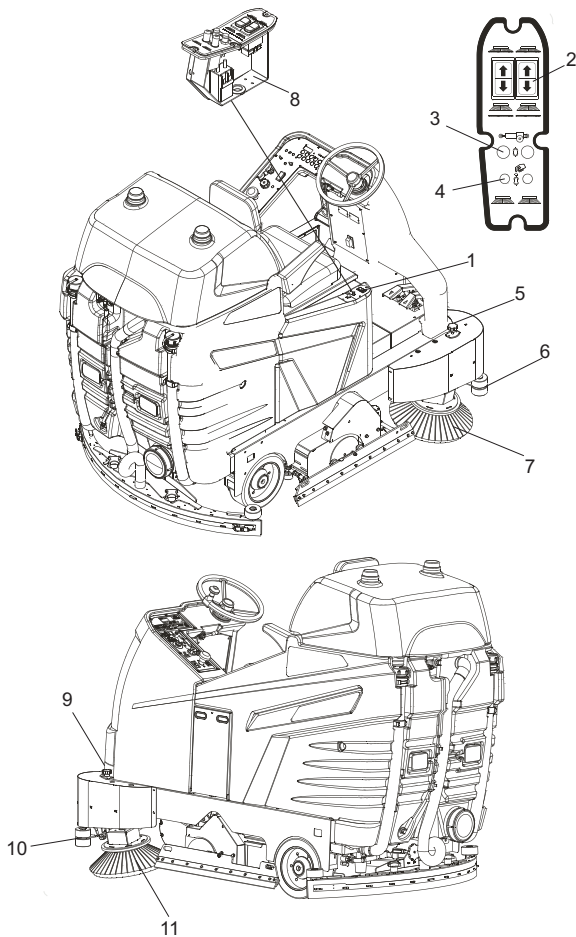

1. SIDE BRUSH CONTROL PANEL
2. BRUSH CONTROL SWITCH RIGHT AND LEFT – pressing the switch into the forward position the corresponding brush lowers and starts to work. Pressing the switch into the rear position the corresponding brush raises and stops working. N.B. – the side brushes function only when the main brushes are working.
3. FUSE - 5A glass fuse to protect the brush lifting actuator.
4. RESET FUSE – When the brush motor exceeds the established current draw for a few minutes, the fuse trips and stops the motor. Wait 1-2 minutes, press the fuse button and the brush will start working again.
5. RIGHT BRUSH PRESSURE ADJUSTMENT HANDWHEEL
6. RIGHT BUFFER ROLLER
7. RIGHT BRUSH
8. REMOTE-CONTROL SWITCH
9. LEFT BRUSH PRESSURE ADJUSTMENT HANDWHEEL
10. LEFT BUFFER ROLLER
11. LEFT BRUSH

## REPLACING AND ADJUSTING THE RIGHT-SIDE SWEEPING BRUSH

To replace the brush, proceed as follows:

- Raise the brush into the non-working position by putting the button into either position 2 or 3 according to the brush (left or right) to be substituted;
- Stop the machine on a flat section of floor, engage the parking brake, switch off the machine and interrupt the power supply;
- Using a specific wrench, loosen the screw pos.2, remove the brush pos.3 from the gear motor shaft;
- Remove the flange pos.4 from the old brush and fit it on the new one;
- Fit everything back together again.

The pressure of the brush on the floor is adjusted by means of the hand wheel pos.5:

- By tightening the hand wheel, the pressure drops;
- By loosening the hand wheel, the pressure of the brush on the floor increases.

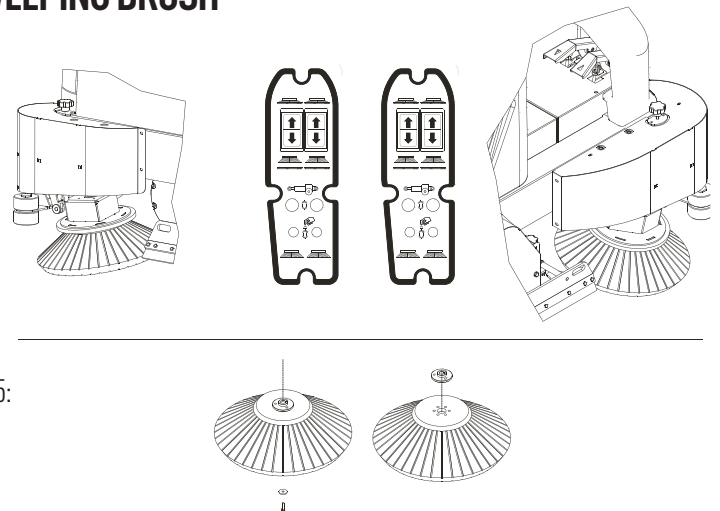

## CONTROL AND REPLACEMENT OF THE FUSE ON THE PANEL

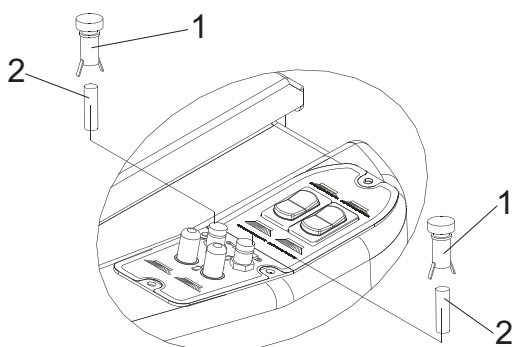

The side brush control panel features a 5A glass fuse to protect the actuator which operates the brush.

To check and replace the fuse proceed as follows:

- Disconnect the battery connector;
- Turn the fuse carrier cover pos.1 by  $\frac{1}{4}$  of a turn anticlockwise and remove it; the fuse is connected to the cover;
- Check and if necessary replace the fuse pos.2, removing it from the cover, with another having the same ampere and features;
- Fit the new fuse in the cover and then fit everything back together again;
- Reconnect the connector to the battery.

### RIGHT SIDE SWEEPING BRUSH EXTENDIBLE

<b>TECHNICAL SPECIFICATIONS</b>	Cleaning path	1.400 mm
	Hourly performance	11.200 m <sup>2</sup> /h
	Weight	730 kg
	Brush dimensions	Ø 420 - 100 RPM
	Brush motor	36V - 200 W
	Noise emission value LpA	67.4 dB (A)
	Whole-body vibration level aW	0.47 m/s <sup>2</sup>

### RIGHT SIDE SCRUBBING BRUSH EXTENDIBLE

<b>SPECIFICHE TECNICHE</b>	Cleaning path	1.335 mm
	Hourly performance	10.680 m <sup>2</sup> /h
	Weight	740 kg
	Brush dimensions	Ø 330x380 - 740 RPM
	Brush motor	36V - 400 W
	Noise emission value LpA	67.4 dB (A)
	Whole-body vibration level aW	0.47 m/s <sup>2</sup>

### RIGHT AND LEFT SIDE SWEEPING BRUSH NO EXTENDIBLE

<b>SPECIFICHE TECNICHE</b>	Cleaning path	1.400 mm
	Hourly performance	11.200 m <sup>2</sup> /h
	Weight	730 kg
	Brush dimensions	Ø 420 - 100 RPM
	Brush motor	36V - 200 W
	Noise emission value LpA	67.4 dB (A)
	Whole-body vibration level aW	0.47 m/s <sup>2</sup>

# SERVICE AND MAINTENANCE RECORDS

1°

## SERVICE AND MAINTENANCE RECORD

**TO 100 HOURS**

**DATE**

DAY	MONTH	YEAR	WORKING HOURS

- Check that the batteries clamps are not loosen or oxidized
- Check the batteries fluid level
- Check the cover gasket
- Check the vacuum motor filter
- Check the brake
- Check, and if necessary replace, the fuses
- Check the brushes and the components of the brush plate
- Check, and if necessary rotate or replace, the squeegee blades
- Check the adjusting/closing detergent solution tap
- Check the detergent solution filter (located just before the pump)
- Check the pump, the solenoid valve, the fitting outgoing from the pump and, if present, the one of the washing side brush
- Check the detergent pump
- Proceed with the cleaning of the ECO system device and its components
- Check the actuators of the squeegee, the brush plate one and the one of the vacuum motor cover (anyway if actuators have problems, they will be detected by the control board)
- Lubricate the squeegee pivot pin
- Test the machine in all its operating functions

**THE SERVICE WAS CARRIED OUT ON:**

**NAME:**

**SURNAME:**

**SIGNATURE:**

**STAMP OF DEALER WHO CARRIED OUT SERVICE**

**NOTES**

2°

## SERVICE AND MAINTENANCE RECORD

**TO 200 HOURS**

**DATE**

DAY	MONTH	YEAR	WORKING HOURS

- Check that the batteries clamps are not loosen or oxidized
- Check the batteries fluid level
- Check the cover gasket
- Check the vacuum motor filter
- Check the brake
- Check, and if necessary replace, the fuses
- Check the brushes and the components of the brush plate
- Check, and if necessary rotate or replace, the squeegee blades
- Check the adjusting/closing detergent solution tap
- Check the detergent solution filter (located just before the pump)
- Check the pump, the solenoid valve, the fitting outgoing from the pump and, if present, the one of the washing side brush
- Check the detergent pump
- Proceed with the cleaning of the ECO system device and its components
- Check the actuators of the squeegee, the brush plate one and the one of the vacuum motor cover (anyway if actuators have problems, they will be detected by the control board)
- Lubricate the squeegee pivot pin
- Test the machine in all its operating functions

**THE SERVICE WAS CARRIED OUT ON:**

**NAME:**

**SURNAME:**

**SIGNATURE:**

**STAMP OF DEALER WHO CARRIED OUT SERVICE**

**NOTES**

**3°**

**SERVICE AND MAINTENANCE RECORD**

**TO 300 HOURS**

**DATE**

DAY	MONTH	YEAR	WORKING HOURS

- Check that the batteries clamps are not loosen or oxidized
- Check the batteries fluid level
- Check the cover gasket
- Check the vacuum motor filter
- Check the brake
- Check, and if necessary replace, the fuses
- Check the brushes and the components of the brush plate
- Check, and if necessary rotate or replace, the squeegee blades
- Check the adjusting/closing detergent solution tap
- Check the detergent solution filter (located just before the pump)
- Check the pump, the solenoid valve, the fitting outgoing from the pump and, if present, the one of the washing side brush
- Check the detergent pump
- Proceed with the cleaning of the ECO system device and its components
- Check the actuators of the squeegee, the brush plate one and the one of the vacuum motor cover (anyway if actuators have problems, they will be detected by the control board)
- Lubricate the squeegee pivot pin
- Test the machine in all its operating functions

**THE SERVICE WAS CARRIED OUT ON:**

**NAME:**

**SURNAME:**

**SIGNATURE:**

**STAMP OF DEALER WHO CARRIED OUT SERVICE**

**NOTES**

**4°**

## SERVICE AND MAINTENANCE RECORD

**TO 400 HOURS**

**DATE**

DAY	MONTH	YEAR	WORKING HOURS

- Check that the batteries clamps are not loosen or oxidized
- Check the batteries fluid level
- Check the cover gasket
- Check the vacuum motor filter
- Check the brake
- Check, and if necessary replace, the fuses
- Check the brushes and the components of the brush plate
- Check, and if necessary rotate or replace, the squeegee blades
- Check the adjusting/closing detergent solution tap
- Check the detergent solution filter (located just before the pump)
- Check the pump, the solenoid valve, the fitting outgoing from the pump and, if present, the one of the washing side brush
- Check the detergent pump
- Proceed with the cleaning of the ECO system device and its components
- Check the actuators of the squeegee, the brush plate one and the one of the vacuum motor cover (anyway if actuators have problems, they will be detected by the control board)
- Lubricate the squeegee pivot pin
- Test the machine in all its operating functions

**THE SERVICE WAS CARRIED OUT ON:**

**NAME:**

**SURNAME:**

**SIGNATURE:**

**STAMP OF DEALER WHO CARRIED OUT SERVICE**

**NOTES**

**5°**

# SERVICE AND MAINTENANCE RECORD

**TO 500 HOURS**

**DATE**

DAY	MONTH	YEAR	WORKING HOURS

CHECK AND REMOVE THE MOTOR CARBON BRUSHES ONE AT A TIME SO AS NOT TO INVERT THEM. THE MOTOR CARBON BRUSHES SETTLE AND WEAR DIFFERENTLY THE ONE FROM THE OTHER, CONSEQUENTLY IF THESE ARE INSPECTED AND PUT BACK ON AGAIN BECAUSE THEY ARE NOT FULLY WORN, THEY MUST BE REFITTED IN THE SAME POSITION.

**VACUUM MOTOR**

Check the carbon brushes and replace them if they are shorter than 10 mm. Length of new motor carbon brush: 26.8 mm.

N°2 carbons (cod 640337) for each motor;

**BRUSHES MOTOR**

Check the carbon brushes and replace them if they are shorter than 9 mm. Length of new motor carbon brush: 19 mm.

N°4 carbons (cod 640307) for each motor;

**MOTORWHEEL**

Check the carbon brushes and replace them if they are shorter than 13 mm. Length of new motor carbon brush: 30 mm.

N°4 carbons (cod 640310) for each motor. Check also the motor oil level in the motorwheel.

- Check that the batteries clamps are not loosen or oxidized
- Check the batteries fluid level
- Check the cover gasket
- Check the vacuum motor filter
- Check the brake
- Check, and if necessary replace, the fuses
- Check the brushes and the components of the brush plate
- Check, and if necessary rotate or replace, the squeegee blades
- Check the adjusting/closing detergent solution tap
- Check the detergent solution filter (located just before the pump)
- Check the pump, the solenoid valve, the fitting outgoing from the pump and, if present, the one of the washing side brush
- Check the detergent pump
- Proceed with the cleaning of the ECO system device and its components
- Check the bearing of the wheels
- Check the actuators of the squeegee, the brush plate one and the one of the vacuum motor cover (anyway if actuators have problems, they will be detected by the control board)
- Lubricate the squeegee pivot pin
- Test the machine in all its operating functions

**THE SERVICE WAS CARRIED OUT ON:**

**NAME:**

**SURNAME:**

**SIGNATURE:**

**STAMP OF DEALER WHO CARRIED OUT SERVICE**

**NOTES**

<b>UP TO 500 HOURS AS FOR 50 HOURS</b>	<b>DATE</b>	<b>DAY</b>	<b>MONTH</b>	<b>YEAR</b>	<b>WORK. HOURS</b>
THE SERVICE WAS CARRIED OUT ON:		<b>STAMP OF DEALER WHO CARRIED OUT SERVICE</b>			
NAME:					
SURNAME:					
SIGNATURE:					

<b>UP TO 600 HOURS AS FOR 100 HOURS</b>	<b>DATE</b>	<b>DAY</b>	<b>MONTH</b>	<b>YEAR</b>	<b>WORK. HOURS</b>
THE SERVICE WAS CARRIED OUT ON:		<b>STAMP OF DEALER WHO CARRIED OUT SERVICE</b>			
NAME:					
SURNAME:					
SIGNATURE:					

<b>UP TO 700 HOURS AS FOR 200 HOURS</b>	<b>DATE</b>	<b>DAY</b>	<b>MONTH</b>	<b>YEAR</b>	<b>WORK. HOURS</b>
THE SERVICE WAS CARRIED OUT ON:		<b>STAMP OF DEALER WHO CARRIED OUT SERVICE</b>			
NAME:					
SURNAME:					
SIGNATURE:					

<b>UP TO 800 HOURS AS FOR 300 HOURS</b>	<b>DATE</b>	<b>DAY</b>	<b>MONTH</b>	<b>YEAR</b>	<b>WORK. HOURS</b>
THE SERVICE WAS CARRIED OUT ON:		<b>STAMP OF DEALER WHO CARRIED OUT SERVICE</b>			
NAME:					
SURNAME:					
SIGNATURE:					

<b>UP TO 900 HOURS AS FOR 400 HOURS</b>	<b>DATE</b>	<b>DAY</b>	<b>MONTH</b>	<b>YEAR</b>	<b>WORK. HOURS</b>
THE SERVICE WAS CARRIED OUT ON:		<b>STAMP OF DEALER WHO CARRIED OUT SERVICE</b>			
NAME:					
SURNAME:					
SIGNATURE:					

<b>UP TO 1000 HOURS AS FOR 500 HOURS</b>	<b>DATE</b>	<b>DAY</b>	<b>MONTH</b>	<b>YEAR</b>	<b>WORK. HOURS</b>
THE SERVICE WAS CARRIED OUT ON:		<b>STAMP OF DEALER WHO CARRIED OUT SERVICE</b>			
NAME:					
SURNAME:					
SIGNATURE:					

<b>NOTES</b>
--------------

# TROUBLE-SHOOTING CHART

## WARNING!

ANY TYPE OF SERVICE OPERATION OR TEST, WITH THE EXCEPTION OF THOSE SHOWN IN THE ENGINE'S MANUAL OR THE BATTERY'S MANUAL, MUST BE CARRIED OUT BY AUTHORIZED SERVICE CENTRES ONLY.

<b>BEFORE ANY INTERVENTIONS CHECK THE CORRECT VOLTAGE OF THE BATTERY: 36V</b>		
<b>PROBLEM</b>	<b>CAUSE</b>	<b>SOLUTION</b>
The battery gets discharged	Either exhaust or broken elements	Replace it
The display of the control card does not switch on when inserting the key	Flat or worn out battery	Recharge it
	5A fuse burn out (pos.2 fuses box)	Replace it
	30A fuse burn out (pos.3 fuses box)	Replace it
	Services supply remote switch faulty	Replace it
	Emergency switch pressed	Unblock it
	Battery mobile connector disconnected	Connect it
	Key operated switch broken	Replace it
	Control board is broken	Replace it
When you press the brush button the brush plate cannot be lowered	Flat or worn out battery	Recharge it
	Faulty actuator	Replace it
	Faulty card	Replace it
	Actuator control module on the control board is broken	Replace it
	Some material got entangled underneath the brush plate thus preventing it from lowering	Remove the material as to unlock the brush plate
	Empty tank. The water output pipe lights are flashing	Fill the tank
	Faulty floating device	Replace it
The brush motor does not rotate	Flat or worn out battery	Recharge it
	Electric remote switch is broken	Replace it
	Control board is broken	Replace it
	Amperometric protection cut-out switch of the motor reduces THE WRITING "E1" APPEARS ON THE CONTROL BOARD	Turn the machine off and start it again by the key, reactivate the cut-out switch. Check that there aren't any threads or any other material which might get tangled with the brush
	The thermal drill of the brush motor reducers intervenes	Wait until the machine gets cool and start it again. Check that there aren't any threads or any other material which might get tangled with the brush
	Carbons are worn out	Replace it
	80A Fuse burn out	Replace it
	Faulty engine	Replace it
The machine doesn't move in reserve speed, but the reverse buzzer works	The reverse microswitch in the pedal box is broken	Replace it
RED LIGHT on the control board; the alarm enters into function and the gear motor comes to a stop.	The temperature on the forward gear motor exceeds 75 – 85 °C	Wait till the temperature falls down before re-starting the machine- Check the reason of the over-heating (climbs, over absorption etc.) Clean the motor air inlets.
	Gear motor thermal probe disconnect or defect	Check the connection or replace the thermal probe
	Faulty relay	Replace it
RED LIGHT on the control board is on, the acoustic alarm enters into function but the traction does not work	Defect temperature alarm relay or disconnected cables	Check the connections or replace it

<b>PROBLEM</b>	<b>CAUSE</b>	<b>SOLUTION</b>
The drive does not work	Brake is engaged	Disengage it
	Flat or worn out battery	Recharge it
	Seat safety device engaged	Sit down
	Key disconnected	Insert it
	125A protection traction fuse is faulty	Replace it
	Wheel gear motor is faulty	Repair/replace it
	Wheel motor is broken or blocked	Repair/replace it
	Motor carbons are worn out	Replace it
	Faulty electric motor remote switch	Replace it
	Electronic control board is broken	Replace it
	Faulty pedal box	Repair/replace it
	Faulty pedal control	Repair/replace it
By pushing the brake pedal, the machine does not stop	Blocked pedal	Check it
	Blocked clamps	Replace it
	Worn clamps	Replace it
	Broken steel rope	Replace it
Not enough water flow on the brush	Pump cut out switch intervention	Engage the cut-out switch
	Tap is closed	Open the tap
	Faulty solenoid valve of the detergent solution.	Replace it
	Clogged detergent solution filter	Clean the filter
	The solution pipe from the tank to the brush is clogged	Make sure there is no incrustations
	Faulty 15A pump fuse	Replace fuse pos. 4 of the fuse-holder.
	Worn out carbons of the pump motor	Replace them
	Pump either clogged or faulty	Check the pump / replace it
	Clogged solution distributor	Clean the pipe fitting
	Control board is broken	Replace it
Not enough water flow on the brush with the ECO-SYSTEM	Pump cut out switch intervention	Engage the cut-out switch
	Faulty ECO-SYSTEM solenoid valve of the detergent solution	Replace it
	Clogged ECO-SYSTEM filter	Clean it
	Control board is broken	Replace it
	Clogged pipe from the recovery tank to the brush	Make sure there is no incrustations
	Faulty 15A pump fuse	Replace fuse pos.4 of the fuse-holder
	Worn out carbons of the pump motor	Replace it
	Pump either clogged or faulty	Check the pump / replace it
	Clogged solution distributor	Clean it
	Eco System cleaning device stuck or damaged	Verify it
When the detergent dosing device is started by means of the switch on the panel, there is little or no detergent flow	Detergent can finished	Replace the can
	Clogged filter on detergent suction pipe	Clean the filter
	Detergent pump blocked or faulty	Check the pump or replace it
	Function control board faulty	Have it replaced
	Dosing device connector blocked	Clean the connector

<b>PROBLEM</b>	<b>CAUSE</b>	<b>SOLUTION</b>
By pressing the vacuum button, the squeegee does not lower	Flat battery	Recharge it
	Reverse speed microswitch engaged	Put the forward speed microswitch
	Faulty actuator	Replace it
	Faulty card	Replace it
	Faulty actuator on the electronic control card	Replace it
	Material underneath the squeegee prevents it from lowering	Remove the material which got entangled in the squeegee
	The recovery tank is full; the floating device gets inserted and the button led is on	Empty the tank
	Faulty float device	Replace it
The vacuum motor does not work	Flat batteries	Recharge them
	30 A vacuum motor fuse worn out	Replace the fuse – Pos. 1 of the fuse holder
	Vacuum motor disconnected	Check the motor wiring
	Vacuum motor is faulty	Replace it
	Vacuum motor carbons are worn out	Replace it
	Control board is broken	Replace it
	Faulty remote switch	Replace it
When you start the vacuum motor, it works for 6/7 seconds, then it stops	Faulty floater	Clean the floater
	Dirty or blocked floater	Replace the floater
	Recovery tank full, floater engaged	Empty the tank
Not enough suction on the squeegee	Recovery tank is full	Empty the tank
	Lid on the exhaust pipe is open	Tight the lid
	Vacuum pipe disconnected	Verify that it is mounted properly
	Vacuum pipe is clogged	Clean the vacuum pipe
	Faulty vacuum pipe	Replace the pipe
	Dirty squeegee	Clean the squeegee
	The squeegee is not adjusted properly	Adjust inclination and pressure
	Material tangled with the squeegee blades	Clean the blades
	Squeegee blades either broken or worn out	Reverse the blade or replace them
	The tank is either open or not properly closed	Close or verify the lid
	Damaged lid gasket	Replace the gasket
	Faulty suction motor	Replace or check the motor
	Flat batteries	Recharge them
	Eco System cleaning device stuck or damaged	Verify it
Front lights and side lights not working	Light faulty	Replace
	Switch faulty	Have it replaced
	Fuse carrier 10A fuse pos.8 faulty	Replace it
	Transformer n°2 faulty	Replace it
	Service supply remote switch faulty	Have it replaced

<b>PROBLEM</b>	<b>CAUSE</b>	<b>SOLUTION</b>
Stop lights not working	Light faulty	Replace
	Micro switch on brake pedal faulty	Have it replaced
	Fuse carrier 10A fuse pos.8 faulty	Replace it
	Transformer n°2 faulty	Replace it
	Service supply remote switch faulty	Have it replaced
Reverse lights not working	Light faulty	Replace
	Reverse light relay faulty	Have it replaced
	Fuse carrier 5A fuse pos.7 faulty	Replace it
	Fuse carrier 10A fuse pos.6 faulty	Replace it
	Transformer n°1 faulty	Have it replaced
	Service supply remote switch faulty	Have it replaced
Reverse buzzer not working	Buzzer faulty	Have it replaced
	Fuse carrier 10A fuse pos. 6 faulty	Replace it
	Transformer n°1 faulty	Have it replaced
	Service supply remote switch faulty	Have it replaced
Flashing lights not working	Lights faulty	Replace
	Fuse carrier 3A fuse pos.5 faulty	Replace it
	Fuse carrier 10A fuse pos.6 faulty	Replace it
	Intermittence faulty	Have it replaced
	Transformer n°1 faulty	Replace it
	Service supply remote switch faulty	Have it replaced
Tank inspection cover does not open	Suction unit on	Switch off suction unit
	Toggle switch faulty	Replace switch
	Toggle switch connector disconnected or badly connected	Check the connector connection
	Relay faulty	Have it replaced
	Fuse carrier 3A fuse pos.10 burnt out	Replace it
	Service supply remote switch faulty	Have it replaced
	Fuse carrier 30A fuse pos.3 burnt out	Replace it
	Actuator faulty	Have it replaced
Charger cooling fan does not work during the battery charge	3A fuse pos.12 in the fuse holder defected	Replace it
	Faulty timer	Have it replaced
	Faulty fan	Have it replaced
When the machine is turned on, the detergent pump and solution pump are triggered at the same time	Check that the detergent pump button is not short-circuited	Replace it

<b>GUASTO</b>	<b>CAUSA</b>	<b>SOLUZIONE</b>
<b>RIGHT SIDE SWEEPING BRUSH EXTENSIBLE</b>		
Brush plate does not come out	Key detached	Insert key
	Fuse burnt out	Replace
	Actuator faulty	Replace
	Brush plate rotation pin blocked	Remove and check pin. If damaged, replace
Brush does not turn	Key detached	Insert key
	Main brush plate not lowered	Lower the brush plate
	Reset fuse tripped	Reset the fuse; if the problem continues, check the causes
	Gear motor faulty	Have it replaced
<b>RIGHT SIDE SCRUBBING BRUSH EXTENSIBLE</b>		
No water comes out	Brush plate not lowered	Lower the brush plate
	LEDs on panel relating to water flow are not lit up	Insert one or more LEDs on panel
	Water control solenoid valve blocked or faulty	Have it replaced.
	Pipe clogged	Clean pipe
<b>RIGHT AND LEFT SIDE BRUSHES FOR SWEEPING NO EXTENSIBLE</b>		
The scrub deck doesn't lower	Key detached	Insert key
	Fuse burnt out	Replace
	Actuator faulty	Replace
	Mechanism that lowers side brushes is blocked	Disassemble and check the mechanism
	Microswitch blocked or damaged	Check the microswitch, replace it if necessary
Brush does not turn	Key detached	Insert key
	Main brush plate not lowered	Lower the brush plate
	Reset fuse tripped	Reset the fuse
	Micro switch faulty	Have it replaced
	Gear motor faulty	Have it replaced

PROBLEM	CAUSE	SOLUTION
	<p>Amperometric protection for over-absorption of the brush motor. The led light of the brush bottom flashes for 1 minute and then the writing E1 appears, the brushes will stop lifting the plate.</p>	<p>Stop the machine and start it again. If the problem persists, check out the cause of over-absorption (threads or any other material which might get tangled with the brush; the brush is not suitable for the type of floor) If the alarm persists, check if there is any oxidation in the 80 Ah fuse that can give a wrong reading.</p>
	<p>The contact of both the brushes actuator limit switches is open.</p>	<p>Make sure that there are no foreign bodies preventing brush plate from functioning. If the problem persists, contact either a retailer or technician.</p>
	<p>The contact of both the squeegee actuator limit switches is open.</p>	<p>Make sure that there are no foreign bodies preventing the squeegee from functioning. If the problem persists, contact either a retailer or technician.</p>
	<p>The final position of the brush plate actuator is not reached within the max. lapse of time (10secs)</p>	<p>Make sure that there are no foreign bodies preventing brush plate from functioning. If the problem persists, contact either a retailer or technician</p>
	<p>The final position of the squeegee actuator is not reached within the max. lapse of time (10secs)</p>	<p>Make sure that there are no foreign bodies preventing the squeegee from functioning. If the problem persists, contact either a retailer or technician</p>
	<p>When starting up the machine, the brushes actuator does not reach the pos. 0 within the max. lapse of time (10 sec.)</p>	<p>Make sure that there are no foreign bodies preventing brush plate from functioning. If the problem persists, contact either a retailer or technician</p>
	<p>When starting up the machine, the squeegee actuator does not reach the pos. 0 within the max. lapse of time (10 sec.)</p>	<p>Make sure that there are no foreign bodies preventing the squeegee from functioning. If the problem persists, contact either a retailer or technician.</p>
	<p>That is not an alarm but rather a warning signal indicating that the brush plate is not in raised position when starting up the machine. The machine requires the brush plate to be lowered before being used for any other operation.</p>	<p>Wait for a few seconds till the brush plate has been raised completely.</p>
	<p>The battery charge level is too much low. Upon reaching level 20 the number on the display shall start blinking and the brush function will be disabled, lifting the plate</p>	<p>Complete drying. Empty the recovery tank and recharge the batteries.</p>
	<p>The battery charge level is too much low. Upon reaching level 10 the number on the display shall start blinking and the suction function will be disabled.</p>	<p>Lift the squeegee, empty the recovery tank and recharge the batteries</p>
	<p>The battery charge level is too much low. When 4 blinking dashes appear on the display unit, it means that the minimum discharge threshold of the battery has reached its maximum level and if the battery is used any further it will cause irreparable damages. At this point, the forward drive will move the machine at a very low speed.</p>	<p>The machine must be taken to the tank drainage area manually to charge the batteries</p>

**WHEN THE GREEN LIGHT IS OFF, THE MACHINE IS WORKING PROPERLY. WHEN THE LIGHT IS FLASHING, THE CONTROL (TRACTION BOARD) REPORTS AN ALARM.**

N° FLASHES	ERROR	CAUSE AND SOLUTION
1	Machine in motion before ignition	The vehicle is in motion when the key is turned on. If the error persists, the traction board can be replaced.
2	Contactor connection problem	Check the cables and coil connections regarding the line contactor. Check the 100A fuse (AN)
3	Low battery voltage	The battery voltage has dropped below the minimum permitted value. Recharge the battery.
4	Overvoltage	The battery voltage has gone above the maximum permitted value. Check that the battery installed is 24V.
6	Broken potentiometer	Check potentiometer cables and connections
7	Overheating	Restore correct temperature. Check wheel motor consumption. Check correct mounting of the controller
8	Shutdown during motion	The control was switched off while the vehicle was moving. Always switch off the traction board when the vehicle is stopped.
9	Incorrect parameter settings	Calibration values are incorrect. Check programming. If the error persists, contact service.
11	Electrical field not properly connected	The control (traction board) cannot get the required field current. Check field winding connections. Switch the machine off and on again.
12	Acquisition failed	Check the calibration of the feed potentiometer. If the error persists, replace the drive board.
23	Error in Serial Communication	Check the serial communication wiring (connector C). If the error persists, contact service.
24	Hardware error	Contact service

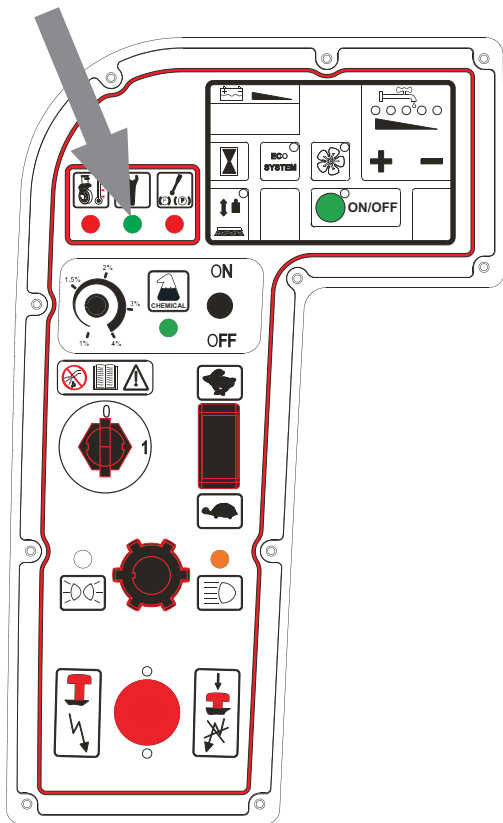

## EU DECLARATION OF CONFORMITY

according to Annex II A of the Machinery Directive 2006/42/CE

The manufacturer that places this product on the market:

**EUREKA S.p.A. Unipersonale**  
VIALE DELL'ARTIGIANATO 30/32, 35013 CITTADELLA (PD) - ITALY

formally declares that the product:

### Scrubber E110-R ECO

complies with the following EU Directives:

**2006 / 42 / CE**  
**2014 / 30 / UE**  
**2014 / 35 / UE**  
**2011/ 65 / UE + 2015 / 863**  
**2009 / 125 / CE**

Machinery Directive, Annex 1  
Electromagnetic Compatibility (EMC) Directive  
Low Voltage Directive  
RoHS 3 Directive  
Energy-Related Products (ErP) Directive

The following harmonised and technical standards have been applied:

<b>EN ISO 12100:2010</b>	Safety of machinery - General principles for design - Risk assessment and risk reduction.
<b>EN 60335-1:2013</b>	Household and similar electrical appliances - Safety - Part 1: General requirements.
<b>EN 60335-2-72:2016</b>	Household and similar electrical appliances - Safety - Part 2: Particular requirements for floor treatment machines with or without traction drive, for commercial use.
<b>EN 55014-1:2019</b>	Electromagnetic compatibility - Requirements for household appliances - electric tools and similar apparatus - Part 1: Emission.
<b>EN 55014-2:2015</b>	Electromagnetic compatibility - Requirements for household appliances, electric tools and similar apparatus - Part 2: Immunity - Product family standard.
<b>EN 61000-6-2:2016</b>	Electromagnetic compatibility (EMC) - Part 6-2: Generic standards - Immunity standard for industrial environments.
<b>EN 61000-6-4:2018</b>	Electromagnetic compatibility (EMC) - Part 6-4: Generic standards - Emission standard for industrial environments.
<b>EN 62233:2008</b>	Measurement methods for electromagnetic fields of household appliances and similar apparatus with regard to human exposure.

Legal representative and person authorized to compile the technical file: Antonio Barile

Cittadella, 15/12/2023

EUREKA S.p.A  
(Legal representative)

