

INSTRUCTION MANUAL

E65 TRAC M

E75/2 TRAC M

E83 TRAC M



EN

Instruction manual
(Original instruction)



Attention: Read the instruction before use
the machine



CONTENT INDEX

PRESENTATION	4
MACHINE IDENTIFICATION	5
GENERAL WARNINGS AND ADVICE	6
CLEANING AND MAINTENANCE	7
DISPOSAL	8
TRANSPORT	9
UNPACKING	9
MACHINE DESCRIPTION	12
MAIN FUNCTIONS AND CONTROLS	14
PREPARATION OF THE MACHINE	16
ADJUSTING THE SQUEEGEE	16
ADJUSTING THE SQUEEGEE WHEELS	16
INSTALLING THE SQUEEGEE	16
MOVING THE BRUSH PLATE.....	17
INSTALLING THE ABRASIVE DISC INTO THE DISC PAD HOLDER	17
INSTALLING BRUSHES AND ABRASIVE DISCS.....	17
ADJUSTING THE SOLUTION QUANTITY ON THE BRUSHES (WATER + DETERGENT)	18
REMOVING BRUSHES AND ABRASIVE DISCS.....	18
FILLING THE DETERGENT SOLUTION TANK	18
SPLASH GUARD LIFTING FOR PRE-WASHING	19
DETERGENT DOSING SYSTEM (OPTIONAL).....	19
USING THE MACHINE	20
CHECK BEFORE USE.....	20
OPERATION.....	20
MAINTENANCE	21
DRAINING AND CLEANING THE RECOVERY TANK.....	21
CHECKING BRUSHES OR ABRASIVE DISCS.....	22
CLEANING THE VACUUM FILTER	22
DRAINING AND CLEANING THE SOLUTION TANK.....	22
CLEANING THE SQUEEGEE	23
REPLACING SQUEEGEE BLADES.....	23
REPLACING THE SPLASH GUARD BLADES	24
CLEANING THE DETERGENT SOLUTION FILTER	24
CHECKING THE GASKET ON THE COVER	24
CHECKING OR REPLACING FUSES.....	25
CHECKING OR REPLACING FUSES IN THE INSTRUMENT PANEL.....	26
CHECKING TO BE MADE EVERY 400 HOURS ON THE DRIVE WHEEL.....	26
DIMENSIONAL TECHNICAL DRAWINGS	27
TECHNICAL CHART	28
SERVICE AND MAINTENANCE RECORDS	30
TROUBLE-SHOOTING CHART	36
EU DECLARATION OF CONFORMITY	40

PRESENTATION

Our company, a leader in the production of industrial cleaning machines, is delighted to have you among the owners of this scrubber and is sure you will be fully satisfied with it. We are sure that during its use, you will see the quality, robustness and possibilities of use it has to offer. This scrubber is suitable for private, industrial or public use. This manual describes the various installation operations, controls and maintenance interventions necessary to maintain perfect efficiency of your scrubber. These are normal maintenance operations that any operator can carry out using devices normally available in a company. For particular works, please contact specialist staff.

OUR COMPANY AIMS TO CONSTANTLY IMPROVE ITS PRODUCTS AND RESERVES THE RIGHT TO MAKE CHANGES AND IMPROVEMENTS WHEN NECESSARY WITHOUT ANY OBLIGATION TO UPGRADE PREVIOUSLY SOLD MACHINES.

ATTENTION!

THE MACHINE IS NOT CERTIFIED FOR ON-ROAD USE.

BEFORE USING THE MACHINE OR CARRYING OUT ANY OPERATION ON IT, ALL THE PROCEDURES AND WARNINGS DESCRIBED IN THIS MANUAL MUST BE READ AND UNDERSTOOD. STRICT COMPLIANCE WITH THE REGULATIONS AND THE INSTRUCTIONS CONTAINED IN THIS MANUAL, COMBINED WITH THE OPERATOR'S ATTENTION AND CAUTION, WILL BE THE BEST GUARANTEE AGAINST ACCIDENTS THAT CAN OCCUR IN THE WORKPLACE.

SCRUBBERS ARE DESIGNED TO PROVIDE UTMOST SAFETY IF USED ACCORDING TO INSTRUCTIONS. THIS MACHINE IS INTENDED FOR COMMERCIAL USE, FOR EXAMPLE IN HOTELS, IN SCHOOLS, IN HOSPITALS, IN FACTORIES, IN SHOPS, IN OFFICES AND IN BUSINESSES.

THIS MACHINE IS NOT INTENDED FOR USE BY PEOPLE (INCLUDING CHILDREN) WITH REDUCED PHYSICAL, SENSORY OR PSYCHOLOGICAL CAPACITY, OR WITH LACK OF EXPERIENCE AND KNOW-HOW. CHILDREN SHOULD BE MONITORED TO ENSURE THEY DO NOT USE THE EQUIPMENT TO PLAY ON.

THE USER MANUAL IS AN INTEGRAL PART OF THE SCRUBBER AND MUST ACCOMPANY IT UP TO ITS DEMOLITION.

PURSUANT TO DIRECTIVE 2006/42 EC, AND DPR 459 ON 24/07/1996 AND SUBSEQUENT UPDATES, IT IS MADE KNOWN THAT: OPERATOR IS INTENDED AS THE PERSON OR PEOPLE RESPONSIBLE FOR INSTALLING, OPERATING, ADJUSTING, CARRYING OUT ROUTINE MAINTENANCE, CLEANING, REPAIRING AND TRANSPORTING THE MACHINE.

THIS COMPANY CANNOT BE HELD LIABLE FOR PROBLEMS, BREAKAGES, ACCIDENTS OR OTHER ISSUES DUE TO LACK OF KNOW-HOW OR NON-APPLICATION OF THE PROCEDURES CONTAINED IN THIS MANUAL, OR DUE TO IMPROPER USE OF THE MACHINE.

THIS COMPANY ALSO CANNOT BE HELD LIABLE FOR CHANGES, INSTALLATION OF PARTS AND/OR ACCESSORIES WITHOUT PRIOR AUTHORISATION.



EMERGENCY SITUATIONS

**IN THE EVENT OF FIRE, ONLY USE POWDER EXTINGUISHERS
IF OCCURS ANY ABNORMAL BEHAVIOR (UNCONTROLLED SPEED INCREASE,
OVERHEATING, ...) TURN OFF THE MACHINE IMMEDIATELY**

MACHINE IDENTIFICATION

The machine and manufacturer are identified through three plates on the rear of the dirt container.

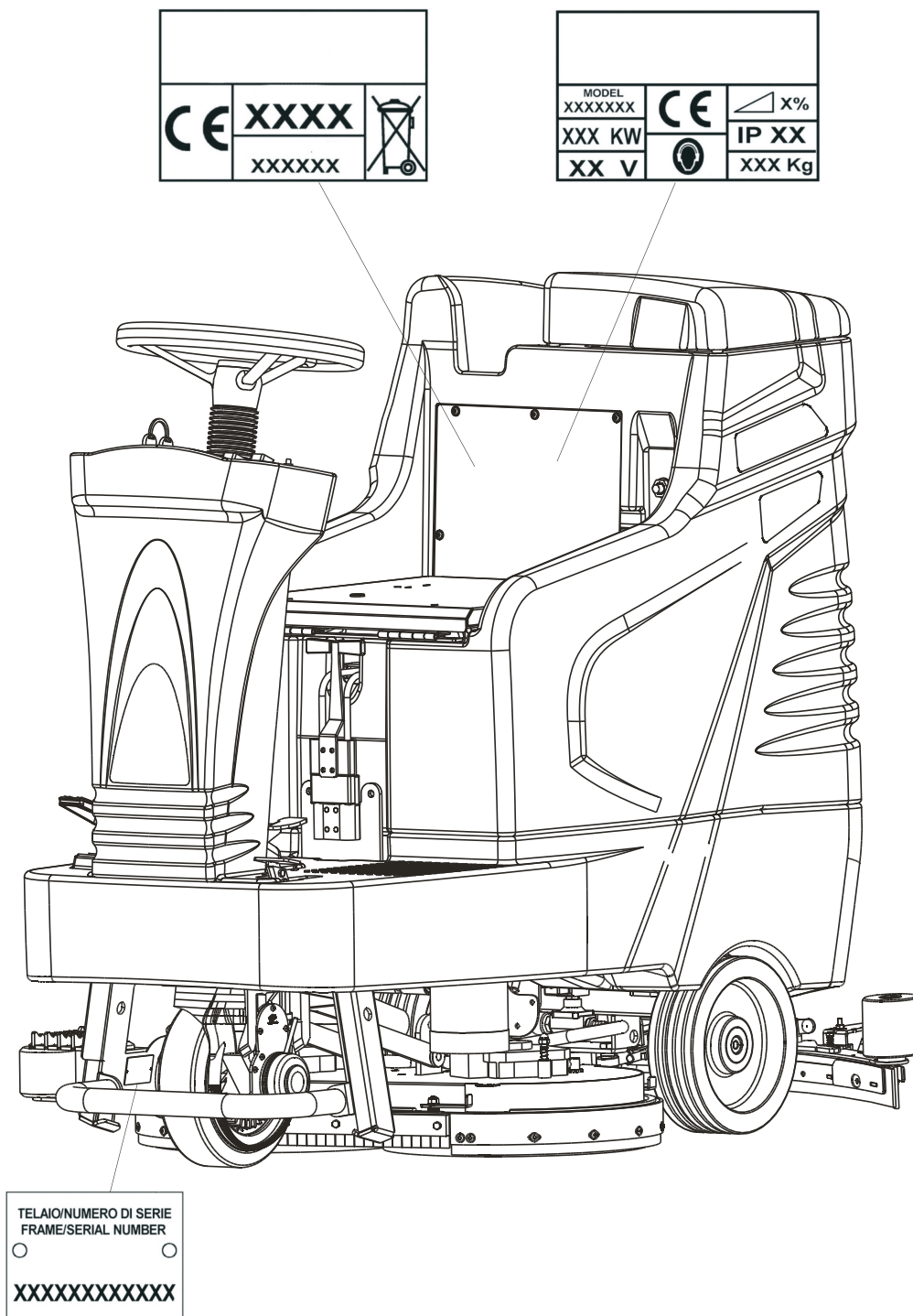

REFER TO THESE DETAILS TO ORDER SPARE PARTS OR WHEN SENDING ANY REQUEST TO THE MANUFACTURER.

The scrubbers comply with EEC directives and display the CE logo.

GENERAL WARNINGS AND ADVICE

DANGER - ATTENTION SIGNS



THIS SYMBOL HIGHLIGHTS ALL THE OPERATIONS THAT REPRESENT A SITUATION OF POTENTIAL DANGER FOR THE OPERATOR.
THEREFORE, PROCEED IN COMPLIANCE WITH THE CONDITIONS HIGHLIGHTED BY THIS SYMBOL



USE OF GLOVES COMPULSORY



USE OF GOGGLES COMPULSORY



ATTENTION: MOVING PARTS, RISK OF TRAPPING HANDS



ATTENTION: DO NOT WET
THE DEVICES MARKED WITH THIS INDICATION MUST NOT GET WET
(THEY ARE NORMALLY ELECTRICAL COMPONENTS)



USE OF ANTI-VAPOUR MASKS WHEN USING CORROSIVE DETERGENTS



RESPONSIBILITIES OF THE OPERATOR

- The operator is responsible for the day-to-day servicing of the machine.
- The operator must care for the machine and keep it in good operating condition.
- The operator must inform his or her superior or the technical department when scheduled maintenance is requested in the case of damage or breakage.
- The operator must not carry people, animals or objects on the machine.
- When moving the machine, observe the safety measures for circulation.
- The machine cannot be used for toxic-harmful materials.
- Never let people get close to the machine's sphere of action.
- Never leave the scrubber-dryer with the key inserted.
- If the machine malfunctions, have a look at the procedures shown in the various chapters.
- Never collect pieces of string, wire or anything else that could damage the brushes by winding around them.
- Never suck up pieces of wood, plastic waste etc. as they may clog the vacuum pipe.
- Never remove or alter the plates on the machine.

IMPORTANT COMMUNICATION

WARNING! DURING THE LAST FEW YEARS, A NEW AGGRESSIVE SOLVENT-BASED DETERGENT TYPE WAS MADE AND DISTRIBUTED IN THE MARKET. THIS DETERGENT IS CURRENTLY NAMED AS "DETER-SOLVENT". EVEN IF THE SOLVENT CONTAINED IN THE DETERGENT IS OBTAINED FROM THE FRUITS, IT STILL HAS TO BE CONSIDERED AS "SOLVENT". THE POLIETHYLENE MATERIAL USED IN THE SCRUBBER TANKS IS MIXED WITH A % OF RUBBER. THE "DETER-SOLVENT" PRODUCT, IF LEFT IN THE SCRUBBER'S TANKS FOR A LONG PERIOD OF TIME COULD ATTACK THE RUBBER'S MOLECULAS, CAUSING THE TANK TO SWELL AND CRACK. IF THE "DETER-SOLVENT" PRODUCT IS USED, IT'S MANDATORY TO RINSE THE TANKS PROPERLY WHEN THE MACHINE STOPS WORKING.



CLEANING AND MAINTENANCE

Machine cleaning must be carried out by staff correctly trained for the purpose, who know the controls to bypass energy sources and are familiar with the characteristics of the machine to avoid dangerous situations.

Clean the coverings of the machine, the panels and the controls with a cloth soaked in water or detergent solution.

No solvents must be used such as petrol, alcohol, etc.

Have specialist staff clean the electrical components who should use non-corrosive products, suitable for electrical circuits.

Maintenance of the machine must be carried out by specialist staff with in-depth knowledge of the machine and its components.

Any maintenance and cleaning must be carried out with the machine off, with all the mechanisms stopped, the hot parts cooled and the battery disconnected.

When using compressed air guns for cleaning, protect eyes and ears.

STORAGE OF THE MACHINE

If the machine is unused for long periods of time, it is essential to:

- Recharge the batteries before storing the machine as empty batteries may get damaged;
- Empty and wash the tanks as described in the relative section;
- Clean the clean water filter, empty the filter protection and drain the water completely from the system;
- Clean the machine inside and outside. Avoid washing the machine using direct water jet, pressurized water, or corrosive substances;
- Keep the brushes and the squeegee raised;
- Remove the key and remove the battery lead connections;
- Keep the machine in a protected place;
- Keep the machine within a temperature range of 5°C / 40 °C;
- Keep the machine within a humidity range of 30°C / 80 °C.

WARNING! When cleaning the machine, avoid using direct water jet, pressurised water, or corrosive substances on the following parts of the machine:

- the brushes gear motors (pos.1);
- the drive motor (pos.2);
- the instrument panel (pos.3).

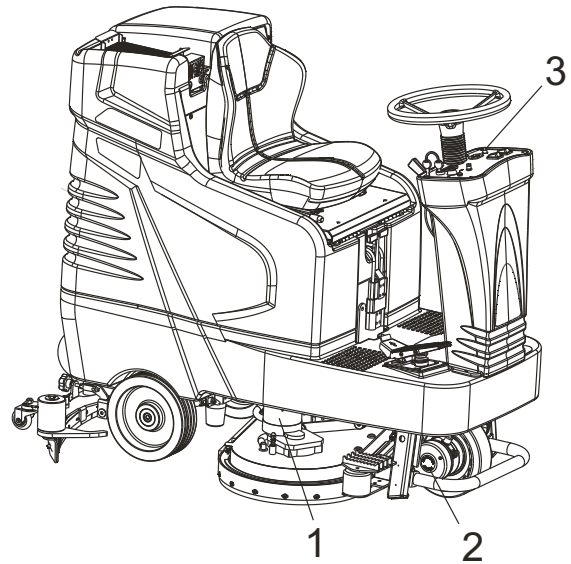

SAFETY PRECAUTIONS FOR OPERATORS AND TECHNICIANS

- The machine must not be used by non-authorized personnel who have not been trained to use it properly or by people who are under the influence of substances that could alter their nervous reflexes (alcohol, psycho pharmaceuticals, drugs etc.)
- Do not use the machine in inflammable areas or where there is the danger of explosions;
- Do not collect material that is alight or anything else that could cause a fire;
- Do not remove protections or guards when the machine is in operation;
- Do not use the machine to clean objects;
- Do not start to perform maintenance operations with parts in movement;
- Protect eyes and ears when using compressed air or water guns for cleaning the machine;
- To raise the machine make use of devices that are adequate to bare the weight of the machine itself;
- Do not cause flames or sparks around the machine;
- Disconnect the battery cables before working on the electrical circuit;
- Avoid contact with battery acid;
- Move carefully over uneven or crumbling paving and on slopes;
- Slow down on slopes and slippery surfaces;
- Make sure the machine is not exposed to rain and bad weather conditions, whether in motion or still;
- Temperature of usage of the machine must be kept within + 5 °C / + 40 °C;
- Humidity should be kept within 30% / 80 %.

RESIDUAL RISK

Residual risk is considered as a potential danger, which is impossible to eliminate or partially eliminate, that can cause harm to the operator if they do not follow correct practices in the work place.

Despite the safety devices provided, some residual risks, as described here below, remain:

1. Risk of electric motor heating, which can lead to burns if contact is prolonged

WAIT FOR AN ELECTRIC MOTOR TO COOL BEFORE TOUCHING IT

2. Risk of rolling

SLOW DOWN WHEN WORKING ON AN INCLINE

3. Risk of collision

SLOW DOWN WHEN WORKING ON WET OR SLIPPERY SURFACES IN ORDER TO AVOID COLLISIONS WITH PEOPLE OR OBJECTS

4. Risk of injury to people

DO NOT STOP IN THE AREA WHERE A MACHINE IS WORKING

5. Risk of fire or explosion during battery charging, with risk of burns or death

NEVER APPROACH THE BATTERY CHARGING AREA WITH AN OPEN FLAME DURING CHARGING. BATTERY CHARGING MUST BE CARRIED OUT IN A VENTILATED AREA, WHICH IS PROTECTED FROM OPEN FLAMES OR EXTERNAL AGENTS THAT COULD CREATE DANGEROUS SITUATIONS. BEFORE CHARGING, CAREFULLY READ THE INSTRUCTIONS IN THE MANUAL AND THE BATTERY SPECIFICATIONS

UPDATING OF THE USER'S MANUAL

When large-scale modifications are made to the machine or new parts are installed, the updated documentation must be sent to the Dealer along with the purchased part or as an update of the manual.

OBLIGATIONS OF THE EMPLOYER OR OWNER OF THE MACHINE

The employer or owner of the machine is responsible for giving the User's Manual to all the personnel who are going to have to use the machine.

The employer or owner of the machine also undertakes to update the manual with the documentation that the Manufacturer will send if modifications are made to the machine.

DISPOSAL



All packaging is recyclable. The packaging should not be thrown away with domestic waste, but sent to the relevant collection centres.

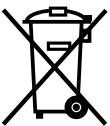

EXHAUSTED LEAD-ACID BATTERIES

Exhausted batteries are considered harmful toxic waste and therefore should be exclusively given to collection companies with specific authorisation (ascertain on hand-over).

MATERIAL COLLECTED FROM THE MACHINE

The waste collected by the machine must be given to the relevant urban cleaning company since it is considered urban waste or similar. The machine cannot be used to collect toxic-harmful materials.

SCRAPPING THE MACHINE

On scrapping, proceed with the correct disposal of the materials that make up the machine. It is compulsory to give the machine to authorised collection companies which will correctly dispose of oil, filters, plastic, metal, electric motors, electric boards, etc. in compliance with legislation in force. Decommissioned equipment contains precious recyclable materials and therefore should be given to the relevant collection centres. Please dispose of decommissioned equipment through differentiated collection systems.

DISPOSAL OF THE RECOVERY TANK SOLUTION

Prior to be moved to specific purification plants, the recovery tank solution is to be disposed of in appropriate sites.



DISPOSAL OF ELECTRICAL EQUIPMENT AND ELECTRONICS



TRANSPORT

The machine must be fixed to a pallet to make it easier to transport and more secure.

At the reception of the machine, check that the packaging is in good condition –in case of damage, inform the forwarder.

PAY ATTENTION WHILE TRANSPORTING THE MACHINE AT TEMPERATURES BELOW 0°C TO PREVENT THE WATER INSIDE THE TANKS AND THE PIPES FROM BECOMING FROZEN.

DRAIN THE TANKS, REMOVE THE SCREEN OF THE CLEAN SOLUTION FILTER AND LET THE WATER FLOW AWAY COMPLETELY OUT OF THE PIPES.



TRANSPORT- HANDLING

Per movimentare la macchina da un luogo d'impiego ad un altro si raccomanda di:

- Not load it on the vehicle with a forklift truck in order not to damage it;
- Lock the machine in place with the parking brake;
- Fix it well to the vehicle using belts, ropes and chains;



TRANSPORTING THE MACHINE BY MANUAL PUSHING

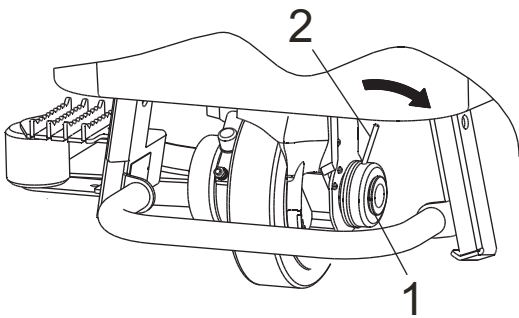

The machine is equipped with an electromagnetic brake (pos. 1) that keeps the machine braked when off or when the drive pedal is not pushed.

When moving the machine manually, the brake must be disengaged by pulling the lever (pos. 2) into the position indicated by the arrow and by keeping it in said position while moving the machine. Move the machine at a walking pace, do not tow it with fork lifts.



UNPACKING

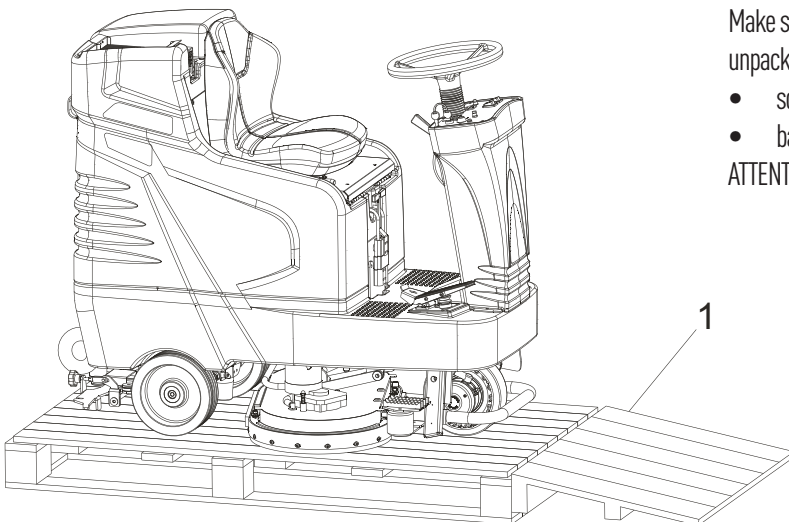

Make sure that all the parts indicated in the following list are present before unpacking the machine:

- squeegee;
 - batteries, cables fitted with connectors, terminals and terminal covers;
- ATTENTION:** brushes, discs and disc pad holders must be purchased separately.

Follow the instructions below to unpack the machine:

- Connect the inclined ramp to the front part of the pallet, as shown in the figure;
- Remove the fasteners fixing the front wheels and any other devices;
- Disengage the electric brake on the front wheel as explained above;
- Make use of the inclined ramp.

DO NOT USE A FORKLIFT TO REMOVE THE MACHINE FROM THE PALLET AS IT MAY CAUSE DAMAGE TO THE MACHINE.



INSTALLING BATTERIES

ATTENTION: USE PROTECTIVE GLOVES AND GOGGLES WHEN HANDLING BATTERIES, AVOIDING ANY CONTACT WITH THE ACID INSIDE THE BATTERIES.

Refer to the specification sheet for battery types and sizes suitable for the machine.

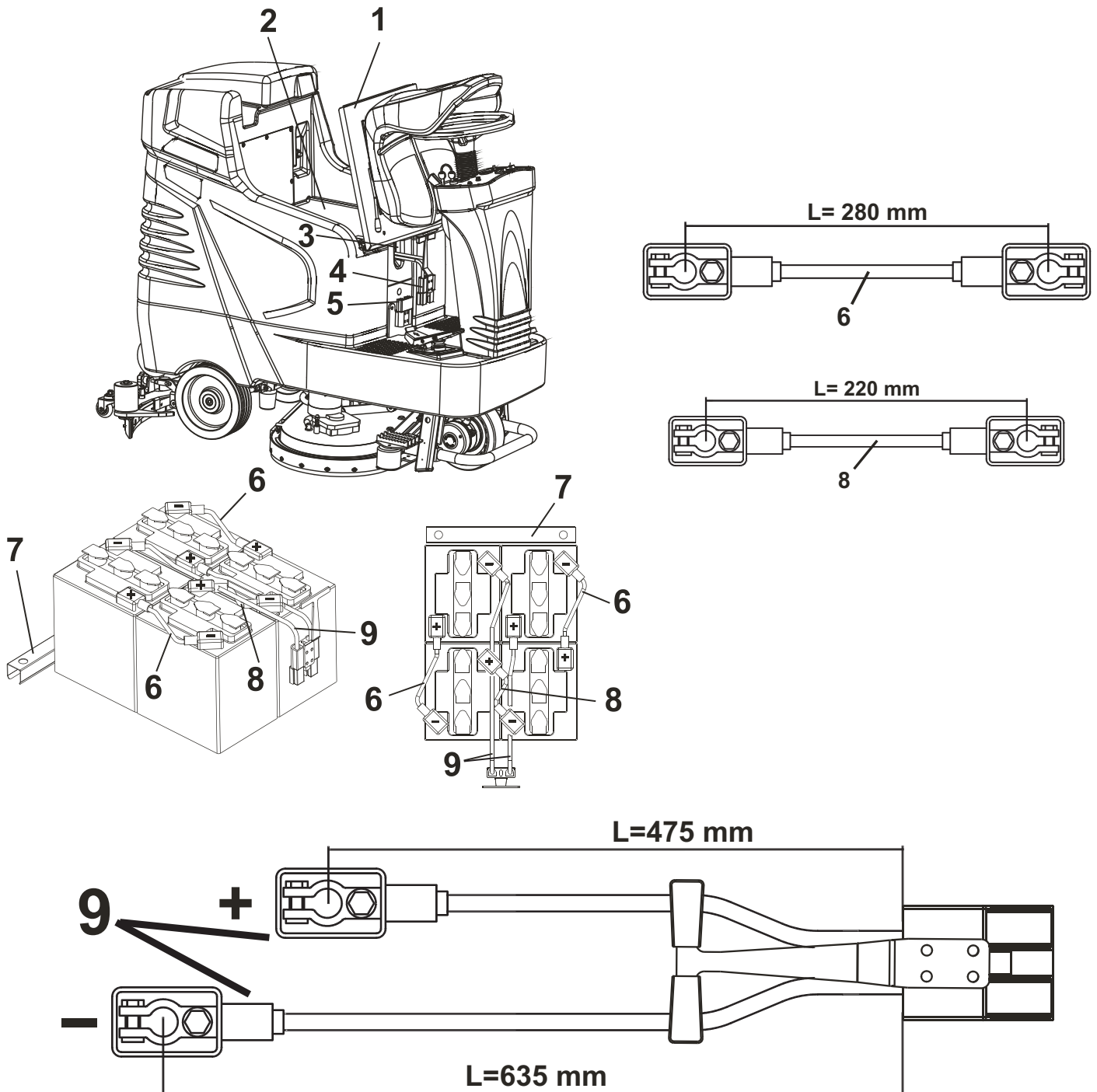

Follow the instructions below to mount the batteries to the machine:

- Park the machine on a levelled area, put on the brake and remove the key;
- Unplug the mobile connector (pos. 4) from the fixed connector (pos. 5);
- Open the hood of the seat (pos. 1);
- Position the four 6V batteries into the battery box inside the battery compartment (pos. 2), if necessary position the spacer (pos. 7) as shown in the figure;

BE VERY CAREFUL NOT TO TIP OVER THE BATTERIES AS ACID COULD SPILL AND DAMAGE THE MACHINE;

- Ensure that the poles of the batteries are clean and apply a thin layer of Vaseline;
- Use the cables (pos. 6-8) provided with the machine and connect the batteries, as shown the in the figure;
- Insert the cables (pos. 9) through the provided opening on the tank (pos. 3) and connect them to the batteries as shown in the figure;
- Connect the mobile connector (pos. 4) to the fixed connector (pos. 5);



RECHARGING BATTERIES USING AN EXTERNAL CHARGER

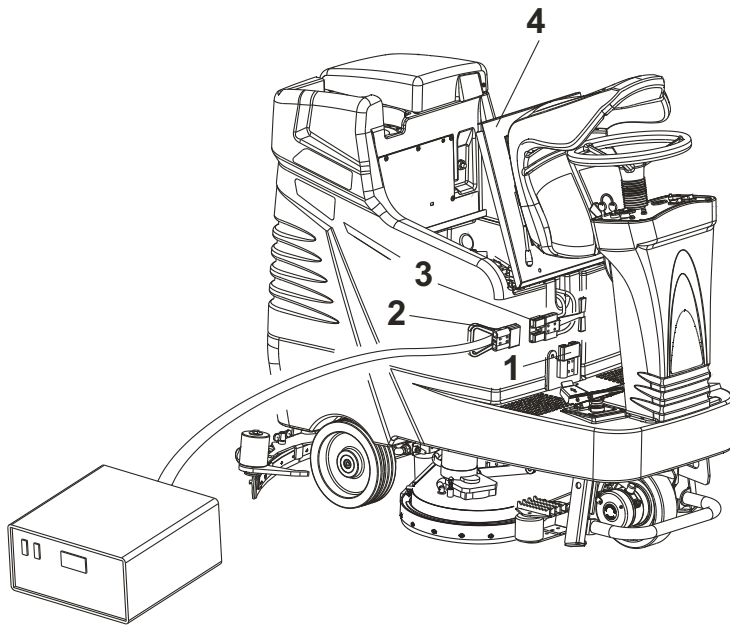

Follow the instructions below to charge the batteries:

- Stop the machine in a levelled area and turn it off;
- Make sure to read the battery charger instruction manual before charging the batteries;
- When charging the battery always do so in a well-ventilated area;
- Open the hood of the seat (pos. 4), unplug the mobile connector (pos. 3) and connect it to the battery charger connector (pos. 2);
- Charge the batteries at no more than one twentieth of their rated capacity;
- Once the batteries are charged make sure to check the electrolyte level and if necessary fill it up only using distilled water;
- Reconnect the mobile connector (pos. 3) to the fixed connector (pos. 1);
- It is recommended to read the battery user manual for further advice on charging the batteries;
- The gas released during the charging process can cause explosions if it meets flames or sparks;
- Battery acid should never come into contact with the eyes, skin or clothes. Make sure to wear goggles, gloves and appropriate clothing;
- In case of contact wash thoroughly with water;
- Do not place metal objects on the battery;
- Do not fill the battery with sulphuric acid or other products.

RECHARGING BATTERIES USING THE CHARGER ON BOARD THE MACHINE (OPTIONAL)

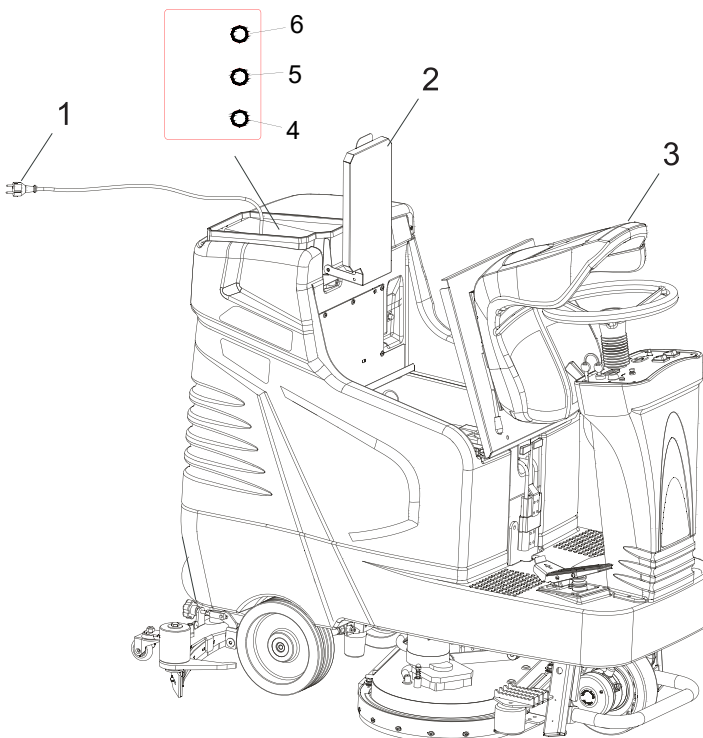

Follow the instructions below to charge the batteries:

- Stop the machine in a levelled area and turn it off;
- Before charging the battery make sure to read the battery charger instruction manual supplied with the machine;
- When charging the battery always do so in a well-ventilated area;
- Open the hood of the seat (pos. 3);
- Open the hood containing the charger pos.2. CHARGER HOOD MUST REMAIN OPEN FOR THE DURATION OF CHARGE.
- Uncoil the cable from the cable reel located on the battery charger and connect the plug (pos. 1) into a standard power socket; **WARNING: WHEN PLUGGING THE BATTERY CHARGER INTO THE ELECTRICAL SOCKET, THE MACHINE FUNCTIONS ARE AUTOMATICALLY DISABLED;**
- On the top of the charger, there are three led
- When the plug is inserted, a double flash of the red led at position 4 indicates that the charger is calibrated for charging lead-acid batteries.
- A double flash of the green LED at position 6 indicates that the charger is calibrated for charging GEL-AGM batteries.
- A double flash of the yellow led at position 5 indicates that the charger is calibrated for charging EXIDE SONNENSCHN / EUREKA GEL batteries.
- A double flash of the red/yellow led at positions 4/5 indicates that the charger is calibrated for charging LITHIUM / EUREKA batteries.
- Once the batteries are charged, make sure to check the electrolyte level and if necessary fill it up only using distilled water.
- The gas released during the charging process can cause explosions if it meets flames or sparks;
- Battery acid should never come into contact with the eyes, skin or clothes. Make sure to wear goggles, gloves and appropriate clothing;
- In case of contact, wash thoroughly with water;
- Do not place metal objects on the battery;
- Do not fill the battery with sulphuric acid or other products;

MACHINE DESCRIPTION

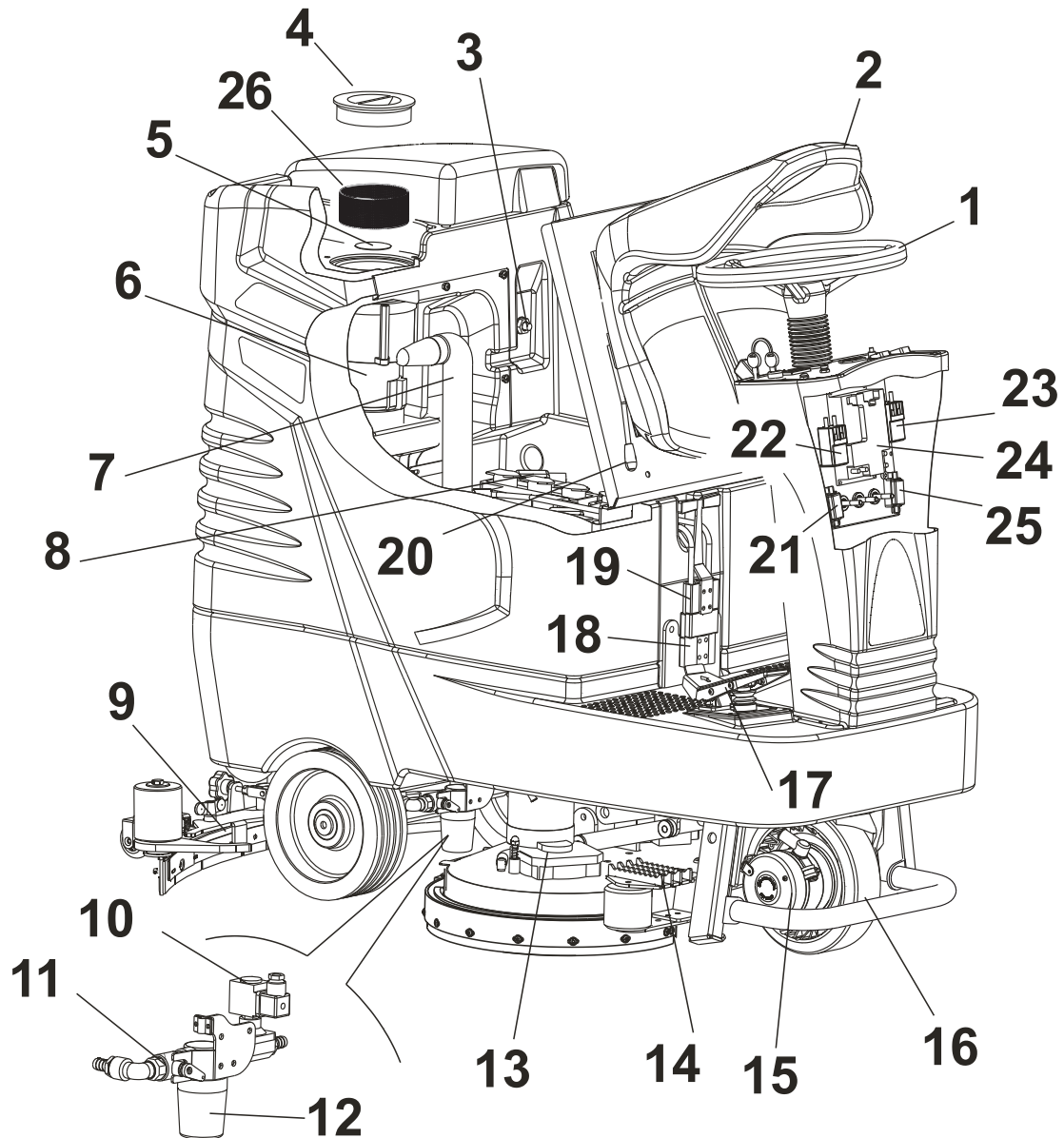

1. HAND WHEEL
2. SEAT
3. MAX LEVEL FLOATING DEVICE OF RECOVERY TANK
4. VACUUM MOTOR FILTER INSPECTION CAP
5. VACUUM MOTOR FILTER
6. VACUUM MOTOR
7. VACUUM MOTOR DISCHARGE PIPE
8. BATTERIES
9. SQUEEGE
10. SOLENOID VALVE
11. SOLUTION FAUCET
12. SOLUTION FILTER
13. BRUSH MOTOR

14. EASY LIFT PEDAL
15. DRIVE WHEEL
16. FRONT WHEEL
17. FORWARD AND REVERSE FOOT PEDAL
18. FIXED CONNECTOR
19. MOBILE CONNECTOR
20. SEAT ADJUSTING LEVER
21. FUSE HOLDER
22. REMOTE CONTROL SWITCH
23. REMOTE CONTROL SWITCH
24. DRIVE CONTROL CARD
25. FUSE HOLDER
26. REMOVABLE FILTER OF VACUUM MOTOR

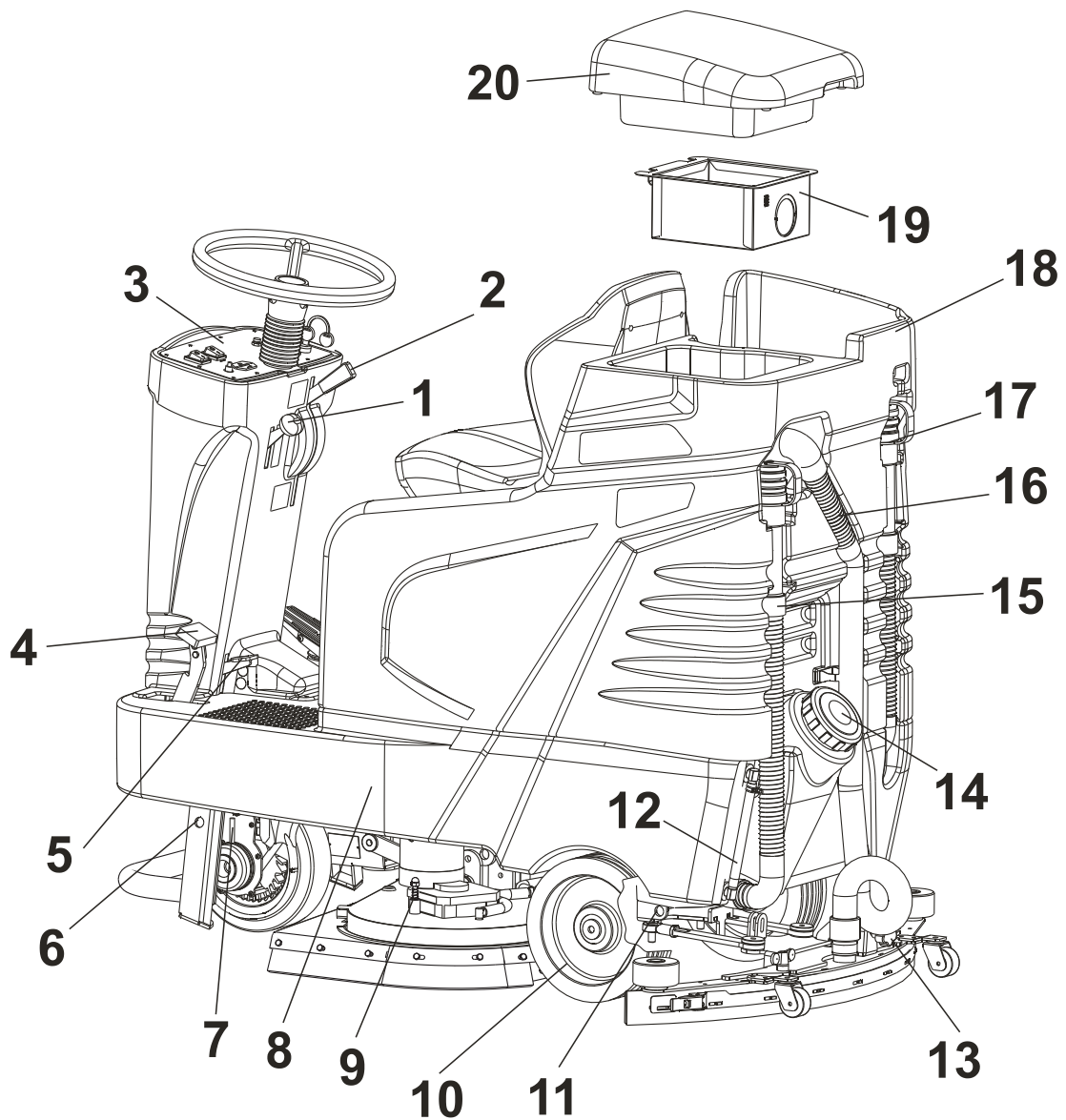

1. SOLUTION ADJUSTMENT LEVER

2. SQUEEGE LIFTING LEVER

3. CONTROL PANEL

4. BRUSH PLATE LIFTING PEDAL

5. BRUSH PLATE PEDAL RELEASE LEVER

6. REAR ANCHORPOINT

7. ELECTRIC BRAKE MANUAL RELEASE

8. SOLUTION TANK

9. BRUSH RELEASE PEG

10. REAR WHEEL

11. MACHINE REAR ANCHORING POINT

12. SOLUTION TANK LEVEL

13. SQUEEGE INCLINATION ADJUSTMENT KNOB

14. SOLUTION TANK FILLING CAP

15. SOLUTION TANK DISCHARGE HOSE

16. SQUEEGE VACUUM PIPE

17. RECOVERY TANK DRAIN PIPE





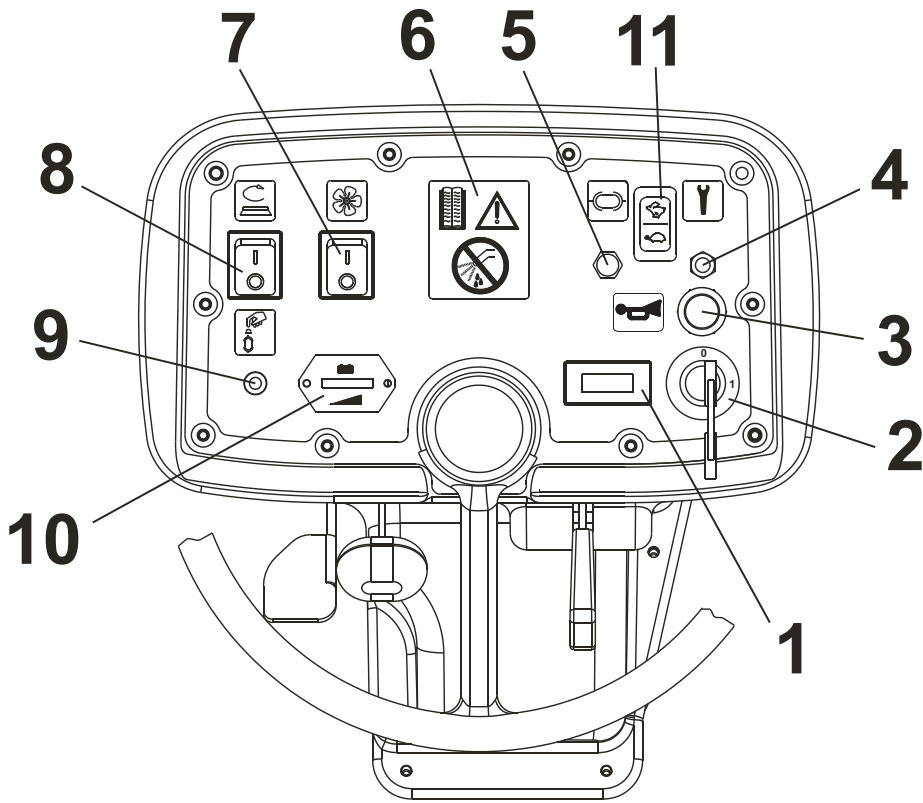

18. RECOVERY TANK

19. MATERIAL COLLECTION BOX

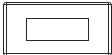
20. RECOVERY TANK COVER

MAIN FUNCTIONS AND CONTROLS



- 1  **HOUR METRE (OPTIONAL)**
- 2  **KEY-OPERATED SWITCH**
Turn it clockwise (pos.1) to turn on the machine.
WARNING: After turning off the machine by the key, wait until 3 -4 seconds before starting it again
- 3  **HORN SWITCH**
Press this button to emit the sound
- 4  **RED LIGHT: DRIVE ALARM**
Indicates any faults in the drive board of the drive motor.
The red indicator light is on during normal operation. The light will start flashing to indicate a fault in the drive system.
The number of flashes indicates the type of fault (consult the troubleshooting table).
- 5  **CONTROL PANEL INSTRUMENT PROTECTION FUSE**
5A glass fuse used to protect the instruments mounted on the control panel
- 6  **WARNING SYMBOLS**
The symbol on the left always recommends using the instruction manual to find any information on the machine, whereas the symbol on the lower part of the machine warns the operator not to get the control panels wet as the electrical parts could get damaged.
- 7  **VACUUM BUTTON**
Push the switch to position 1 to turn on the vacuum.
Push the switch to position 0 to turn off the vacuum.
The vacuum function could deactivate automatically if the solution tank is too full.
The machine is equipped with a float that turns off the vacuum when the tank reaches its maximum level.

8



BRUSH DRIVE BUTTON

Push this switch to position 1 to activate the brush function.

The brushes will start spinning when the brush plate is lowered and once the forward and reverse gear pedal is pushed.

When the pedal is released the brushes will spin for another 2 seconds before stopping.

The solenoid valve is connected to the brush function; it opens and closes the solution flow automatically.

Push this button to position 0 to stop the brushes and close the solenoid valve.

9



BRUSH MOTOR PROTECTOR FUSE

When the brush motors exceed a power draw the fixed consumption, the fuse will engage and stop the motors.

Wait 1-2 minutes then press the fuse button and the brushes will resume operation.

If it occurs repeatedly, check to see if there are any objects that prevent the brushes from spinning freely or if the type of brushes is suited for the type of floor.

10



BATTERY CHARGING INDICATOR

The green LED light indicates that the battery is charged.

When the red light comes on after about 20 seconds, the brush motors will stop running.

Go to the charging zone and charge the battery.

Warning: The indicator is configured for acid-lead batteries.

To avoid damaging the batteries, make sure to change the settings when installing other types of batteries (GEL, AGM, etc).

In case different batteries are fitted (GEL, AGM, etc.) the setting must be changed to avoid damaging the batteries (SEE AT THE BOTTOM OF THE PAGE)

11

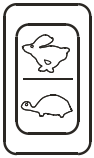

HIGH/LOW SPEED BOTTON

Pushing the hare side, there is a normal speed

Pushing the turtle side, the forward and reverse speed is reduced of a 50%



EMERGENCY SITUATIONS

To stop the machine in case of an emergency and lock all functions, unplug the mobile connector (pos. 2) from the fixed connector (pos. 1) by pulling the handle upwards (pos. 3).

To resume the machine's normal operation, plug the mobile connector (pos. 2) into the fixed connector (pos. 1) and push the handle (pos. 3) downwards until it is released.

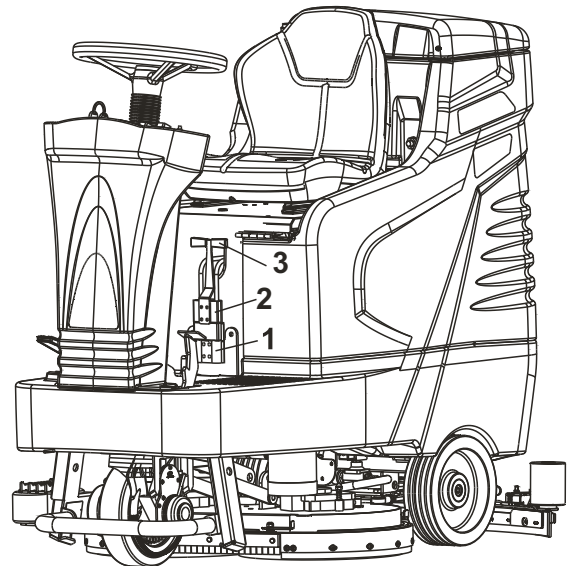

SETTING THE CHARGE INDICATOR

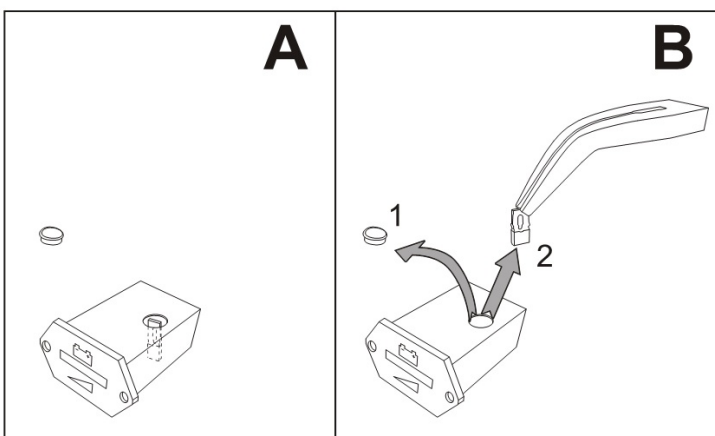

With the jumper inserted, the charge indicator is set for lead acid batteries (FIG.A). Without the jumper, the charge indicator is set for gel/agm batteries (FIG.B). If the indicator is set for gel/agm batteries and you want to install lead acid batteries, please contact the company for the jumper.

PREPARATION OF THE MACHINE



INSTALLING THE SQUEEGEE

Follow the instructions below to assemble the squeegee:

- Park the machine in a levelled area, turn it off and remove the keys;
- Lift the squeegee support with the provided lever (pos.9);
- Place the squeegee (pos.1) in the support (pos.5) and centre the knobs (pos.2) into the slits of the support (pos.5);
- Once it is placed correctly, fix the knobs (pos.2);
- Place the squeegee pipe from the curved end (pos.7) into the hole provided in the tank (pos.8) and push it thoroughly until it fits into place;
- Mount the other end of the pipe, the rolled end (pos.3), into the squeegee sleeve (pos.4);
- Place the pipe into the provided locking springs (pos.6).

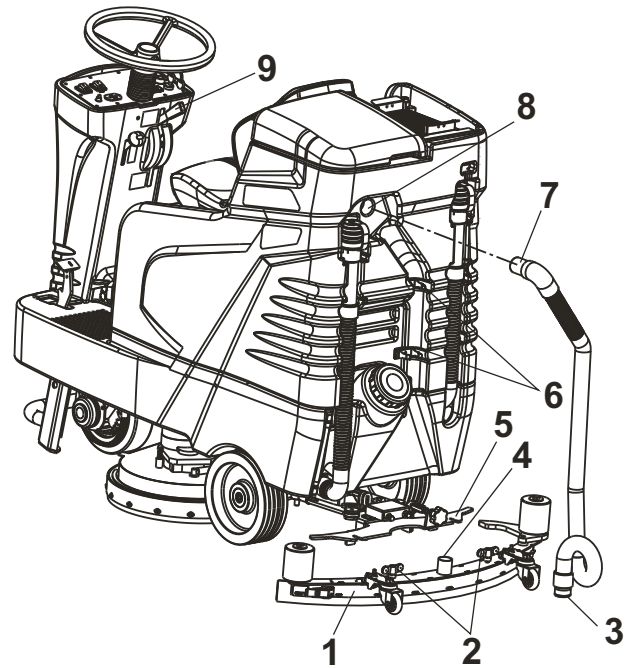

ADJUSTING THE SQUEEGEE

Adjust the squeegee inclination using the knob (pos.1).

The knob adjusts the squeegee so as to have a constant pressure throughout the entire length of the blade (pos.2).

If there is too much pressure on the external tips and little pressure on the central zone, turn the knob anti-clockwise.

If there is less pressure on the tips and too much pressure on the central zone, turn the knob clockwise.

To make the adjustments, lower the squeegee using the lever (pos. 3), turn on the vacuum and drive slowly.

Monitor the distribution of the pressure on the blade and if necessary correct the inclination as described above.

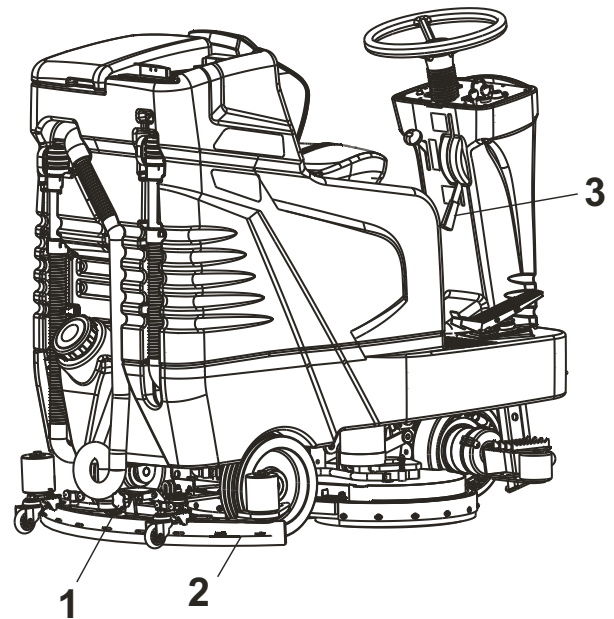

ADJUSTING THE SQUEEGEE WHEELS

Pressure adjustment, using the nut for the wheels' adjustment (pos.1)

This allows for optimal pressure on the blade (position 2 previous picture) which can be adjusted for each type of floor and for each type of blade.

For rough floors or uneven floors, increase the pressure by turning the knob (pos.1) counter-clockwise. For smooth floors, lower the pressure by turning the knob clockwise.

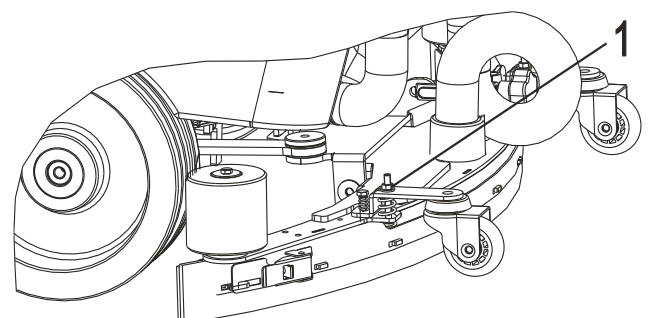



MOVING THE BRUSH PLATE

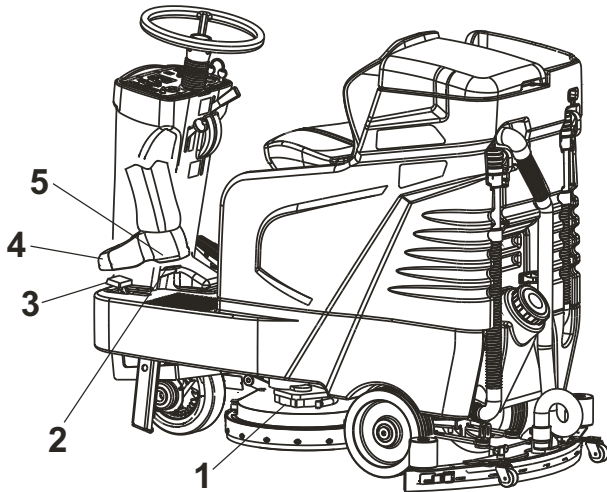

Use the pedal (pos.3) to move the brush plate (pos.1). To lower the brush plate use the heel of the foot (pos.5) to push the release lever (pos.2). Use the toes of the foot (pos.4) to follow the pedal (pos.3) until the brush plate (pos.1) leans against the floor.

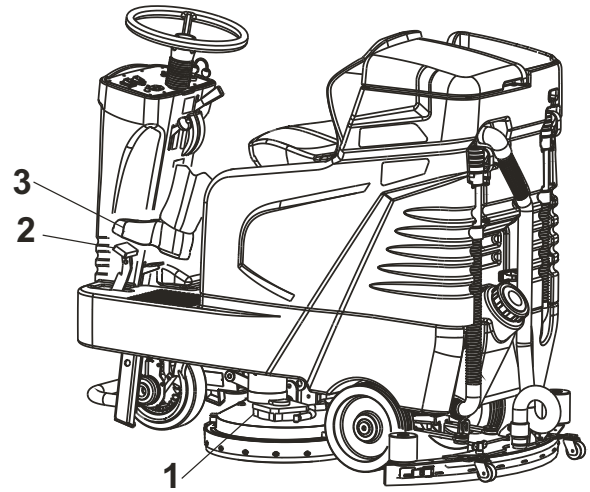

To raise the brush plate (pos.1) use the foot (pos.3) and push the pedal (pos.2) until it is locked into place.



INSTALLING THE ABRASIVE DISC INTO THE DISC PAD HOLDER

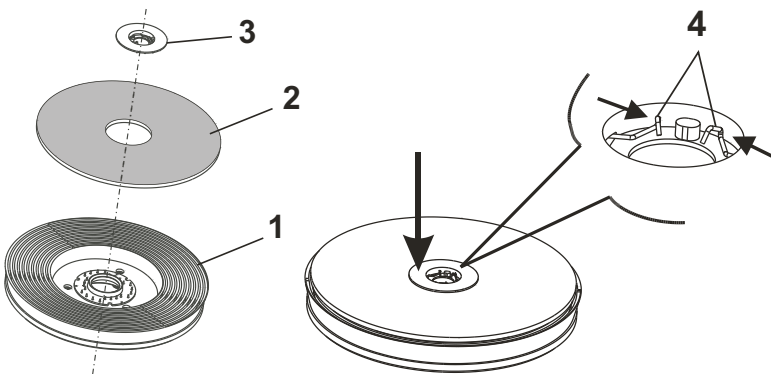

The machine can either work with brushes or with different types of abrasive discs mounted on the provided driving devices.

To mount the abrasive disc on the disc pad holder, follow the instructions:

- Remove the disc lock (pos. 3) from the driving device (pos. 1) by pushing the 2 ends of the fixing spring (pos. 4) against each other;
- Position the abrasive disc (pos. 2) and centre it on the driving device (pos. 1);
- Place the disc lock (pos. 3) on the centre and apply force pushing it until the spring (pos. 4) locks into place. Use the palm of the hand to do so or a foot if the driving device is placed on the floor.



INSTALLING BRUSHES AND ABRASIVE DISCS

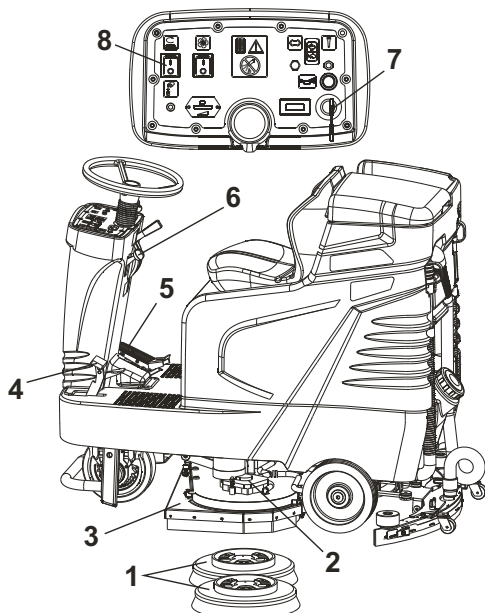

To attach the brushes or the driving devices with the abrasive discs, follow the instructions:

- Turn the key (pos. 7) to position 0 to turn off the machine, making sure that the brush plate is raised;
- Position the brushes or disc pad holders (pos. 1) beneath the brush plate (pos. 2) using two hands to lift the splash guard (pos. 3);
- Lower the brush plate (pos. 2) using the pedal (pos. 4) following the instructions on how to move the brush plate;
- Turn the key (pos. 7) into position 1 and push the brush switch into position 8;
- Slightly push the drive pedal (pos. 5). The brush motors will start running and the machine will start to move slowly.
- Go back and forth using the forward and reverse gear until the brushes are locked into place;
- While performing this operation, it is recommended to close the water using the lever (pos. 6) to avoid spills.



REMOVING BRUSHES AND ABRASIVE DISCS

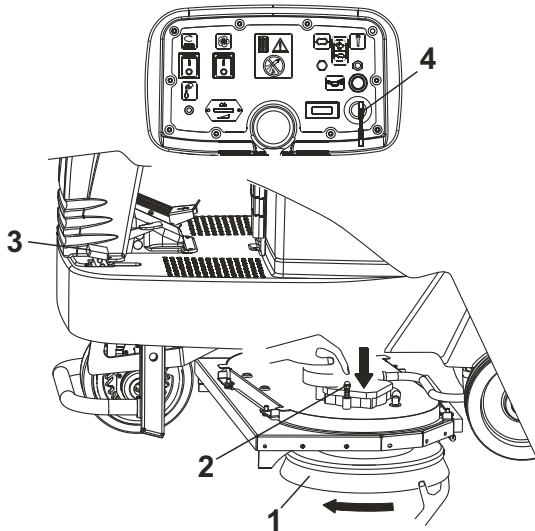

To remove the brushes or the driving devices with the abrasive discs, follow the instructions:

- Turn the key (pos. 4) into position 0 to turn off the machine;
- Unplug the battery mobile connector from the fixed connector by pulling the handle upwards;
- Use the pedal (pos. 3) to raise the brush plate;
- Press the button (pos. 2) and use one hand to turn the brush (pos. 1) into the direction indicated by the arrow until the brush no longer spins freely.
- At this point, pull towards the direction indicated by the arrow using force until the brush is detached;
- Repeat the same operation on the other brush following the opposite direction;



FILLING THE DETERGENT SOLUTION TANK

The tank should be filled using clean water mixed with appropriate detergent solution suited for the type of floor and based on the condition of the floor. A product suitable for cutting down excess foam should also be used.

- Go to the rear part of the machine;
- Unscrew the cap (pos. 1);
- Pour the detergent directly from the canister (pos. 2) into the tank. Consult the package for information about the percentage of detergent to use, the mixing procedures and safety measures to keep in mind.
- Use low-foaming liquid detergents or a suitable product to cut down foam.
- After pouring the detergent solution, use a rubber hose (pos. 3) connected to the water supply system to fill the T.
- The water used to fill the tank must not exceed 40°C.

WARNING: DO NOT POUR FLAMMABLE LIQUIDS INTO THE TANK

- Once the tank is full, screw the cap back on (pos.1).

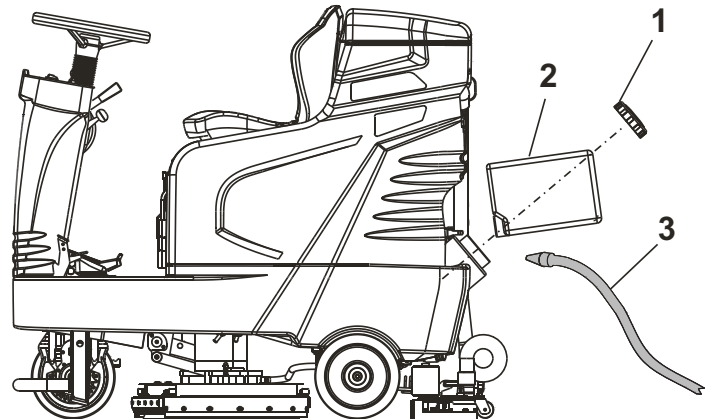

ADJUSTING THE SOLUTION QUANTITY ON THE BRUSHES (WATER + DETERGENT)

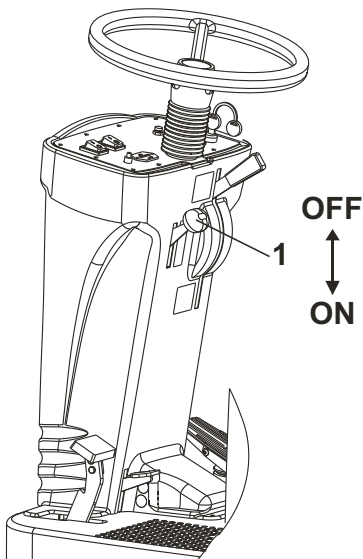

The solution quantity on the brushes can be adjusted using the lever (pos. 1).

While in up position, the lever will shut off the flow of the solution completely.

Push down the lever gradually so that the valve can open and increase the flow of the solution progressively.

Adjust the flow according to the operating speed and the dirt conditions of the floor.

A solenoid valve keeps the solution from spilling out when the machine comes into a stop position.

SPLASH GUARD LIFTING FOR PRE-WASHING

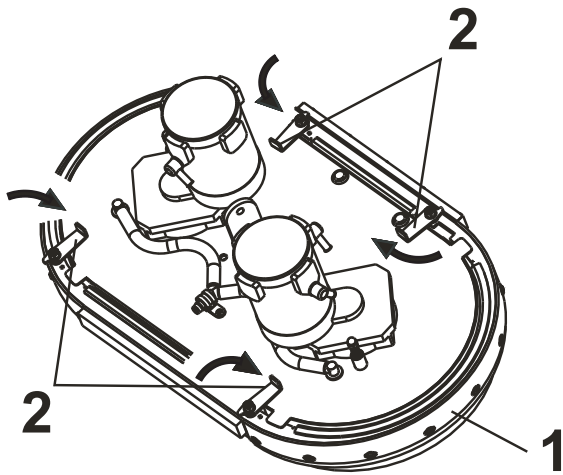

When using the machine to wash floors particularly filthy, it is recommended to pre-wash the floor, allowing the chemical product of the detergent solution to act more effectively to remove dirt.

Therefore, wash the floor without collecting the solution with the squeegee. During this operation, it is recommended to lift the splash guard of the machine to allow an even distribution of the detergent product on the floor.

Go over the area again after several minutes in order to dry the floor, once the splash guard is lowered and the vacuum function is engaged.

Follow the instructions below to lift the splash guard:

- Stop the machine in a levelled area, turn off the machine and remove the keys;
- Lower the brush plate following the procedure described above;
- Use one hand to lift the splash guard (pos.1) upwards;
- Rotate the 4 locking levers into the direction indicated by the arrows. In this manner, the splash guard will remain lifted from the floor.
- Once the pre-wash operation is completed, release the levers (pos.2) and allow the splash guard to descend (pos.1).

DETERGENT DOSING SYSTEM (OPTIONAL)

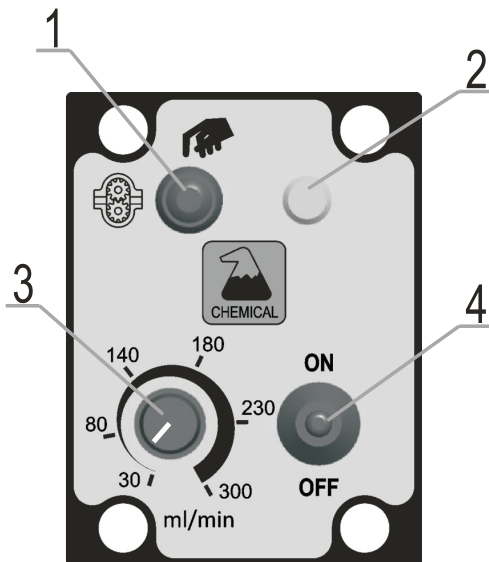

Fix the tank containing the detergent by strap pos.6 and put in the tank tube pos.7. To operate the detergent dosing pump turn ON the toggle switch pos.4. When the pump is on the light pos.2 comes on green. **WARNING: THE PUMP DETERGENT DOSING PUMP WORKS ONLY WHEN THE BRUSHES ARE ACTIVE.** The amount of detergent fed into the solution is adjusted by potentiometer pos.3 (the amount of detergent varies from 30 to 300 ml / min depending on the position of the potentiometer as indicated on the dashboard). To turn off the pump set the switch pos.4 to OFF.

To bleed the circuit, turn the switch pos.4 ON, press the button pos.1 and use clean water.

To remove the complete system of detergent dosage off the machine:

- Push the quick release fitting pos.8 towards the machine and pull the tube to disengage;
- Disconnect the connector pos.9;
- Pull the hook positioned under the structure pos.5, lifting the group and remove it from the machine.

To reassemble the kit on the machine, align 3 pegs on the back of the group with the holes on the fixing plate, lower the group that will snap automatically to the machine.

Reconnect the hose and the electrical connector to the machine.

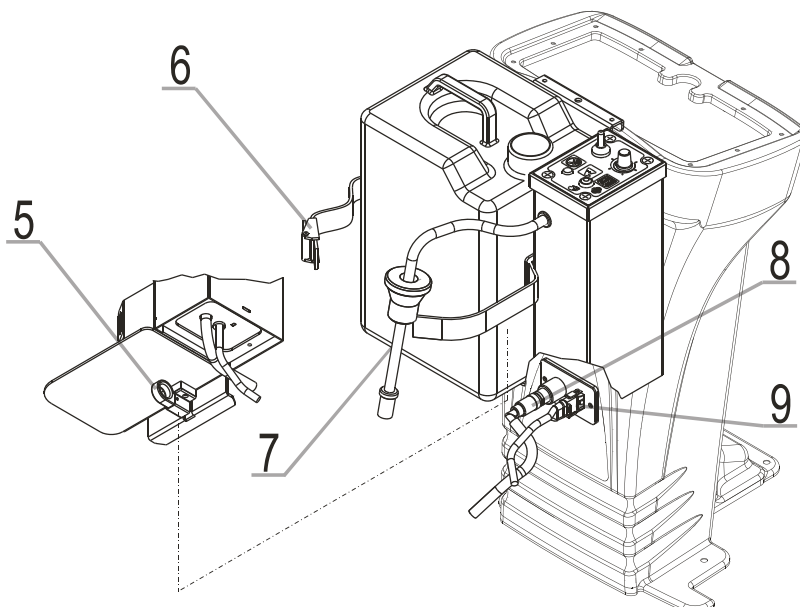

USING THE MACHINE

Our scrubber-dryers must be operated by authorised staff who have been properly trained. Scrubber-dryers that do not operate properly must be taken out of service immediately.

CHECK BEFORE USE

Make sure to check the following before using the machine:

- Make sure the battery connector is plugged-in;
- Make sure the key is inserted correctly;
- Check the battery charge level.

The charge indicator located in the instrument panel displays the charging level of the batteries.

Make sure to charge the batteries when the battery charging level is low.

- Make sure the brushes or discs are in good condition and mounted correctly;
- Make sure the splash guard mounted on the brush plate is in good condition;
- Check the integrity of the rubbers of the squeegee and ensure they are set properly.

OPERATION

- Turn the key to pos.1;

WARNING: After turning off the machine by the key, wait until 3 -4 seconds before starting it again



- Lower the brush plate and push the brush switch to pos.1.

The brushes will start spinning only when the machine starts moving forward;



- Lower the squeegee and push the vacuum switch to pos.1.

The vacuum will start immediately. The machine is also fitted with a float that shuts off the vacuum motor when the water level in the recovery tank is too high;



- Use the provided lever to set the desired solution quantity.

Before starting the washing operation, check the quantity of solution present in the tank using the gauge located in the rear part of the machine.

Fill the tank if the quantity is low;

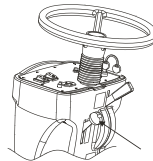

- The working speed can be selected by pressing the slow / fast button: choosing the hare side, the machine works at normal speed; choosing the turtle side the forward and reverse speed is reduced of a 50%;



- When starting the washing operation, make sure to lubricate the edge of the splash guard blades.

As soon as the brush plate lowers with the detergent solution opened, slowly move the machine back and forth for 1 metre in order to get the splash guard rubber wet. This operation will protect the edge of the splash guard blades and increase their durability;

- To avoid damaging the floor, be very careful not to stop the machine over the same area while the brushes continue to spin;
- When the operator stops the machine, the brushes will stop spinning automatically 2 seconds after the drive pedal is released. The flow of the solution will shut off when closing the solenoid valve. When resuming the drive operation, the brushes will restart spinning and the solution will restart to flow automatically;
- If the squeegee leaves wet streaks on the floor during the washing operation, it means that there are pieces trapped beneath the rear rubber of the squeegee. Lift the squeegee and remove the trapped pieces. Use a cloth to wipe off the rear rubber if the pieces cannot be removed.

In any case, it is always advisable to sweep the floors before washing;

- Before washing floors particularly filthy it is advisable to pre-wash the floors according to the instructions provided above;
- At the end of each washing operation, lift the brush plate and the brushes will stop spinning, shutting off the solenoid valve automatically every time the brush plate is lifted. Disengage the function by pushing the brush button to position 0.

After lifting the brush plate, proceed for several metres with the squeegee lowered to finish the drying operation. Lift the squeegee using the provided lever and wait for several seconds before turning off the vacuum using the switch, this will prevent water droplets from falling into the floor.

MAINTENANCE

SERVICING YOUR SCRUBBER-DRYER REGULARLY AND PERIODICALLY WILL ENSURE BETTER PERFORMANCE AND MORE DURABILITY. THE FOLLOWING PAGES CONTAIN INFORMATION THAT WILL HELP YOU PLAN THE MAINTENANCE AND CARE FOR THE MACHINE NEEDS.

WARNING!: DO NOT PERFORM ANY MAINTENANCE ON THE MACHINE OR ANY OF ITS COMPONENTS WITHOUT TURNING OFF THE MACHINE AND UNPLUGGING THE BATTERY CONNECTOR.

WARNING!: DO NOT TAMPER WITH ANY SAFETY DEVICE.

THESE DEVICES CAN ONLY BE REMOVED WHEN PERFORMING MAINTENANCE BY AN AUTHORISED ASSISTANCE CENTRE (AAC).



DRAINING AND CLEANING THE RECOVERY TANK

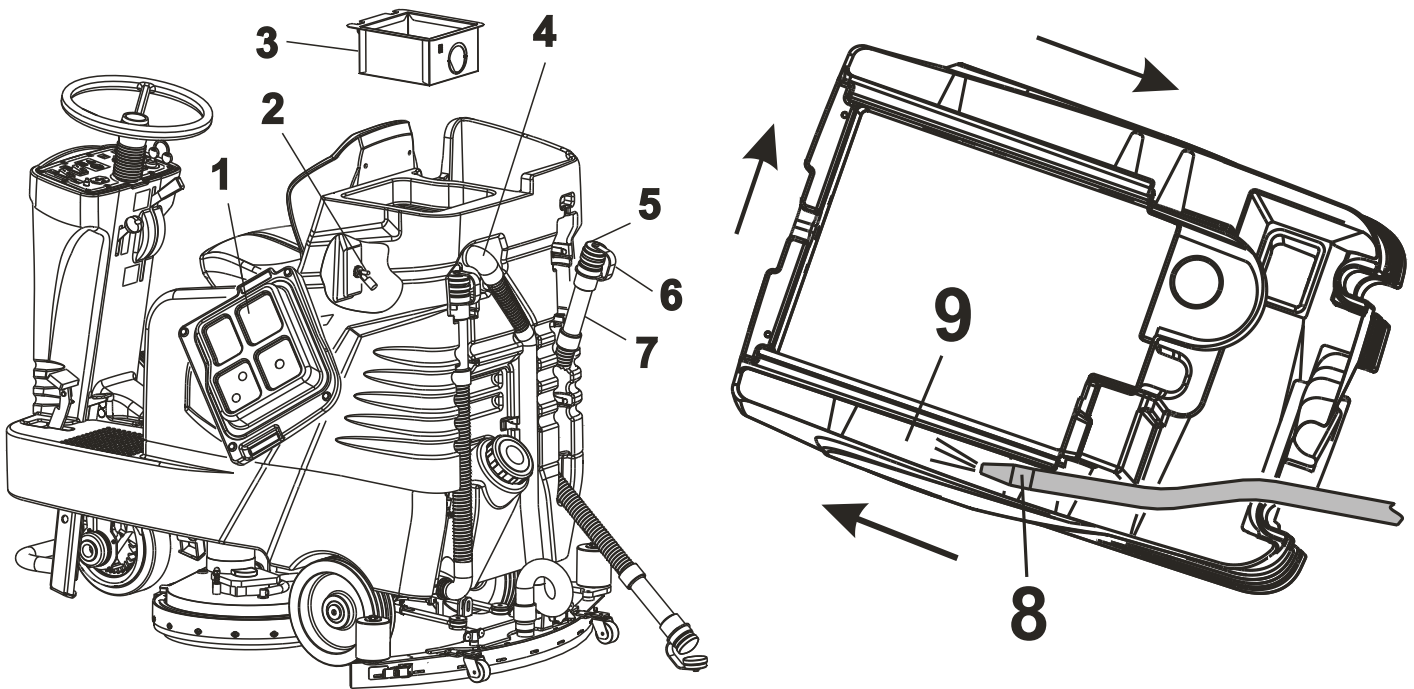

The recovery tank must be drained and cleaned after each washing operation.

Follow the instructions below to wash and drain the tank:

- Lift the brush plate and turn off the switch on the control panel;
- Lift the squeegee and turn off the vacuum function after 10 seconds, using the switch on the control panel;
- Go to the provided area to drain the tank;
- Turn off the machine and remove the key;
- Remove the cover (pos.1) and hang it next to the tank;
- Remove the dirt collection box (pos.3) by lifting it first from the front part to remove it from the tank. Empty the box into the provided waste container.

Wash the box with water and remove any pieces trapped in the mesh;

- Remove the drain pipe from the dirty water tank (pos.6) and while keeping the pipe vertically (pos.5) turn the cap counterclockwise to unscrew it. Part of the pipe is flexible (pos.7), allowing it to be squeezed to limit the water flow. Once it is open, place the pipe on the ground;
- After draining the tank, make sure to wash the inside thoroughly using water. Fit the water pipe (pos.8) into the left side of the tank (pos.9) and run abundant water to wash the front part and right side;
- Clean the level sensor (pos.2) very carefully. Do not apply water jet directly onto the sensor as this could damage it. If necessary, clean it using a piece of cloth and remove any deposits (metal residue) that could prevent the float from closing correctly;
- Wash the squeegee vacuum pipe regularly (pos.4) to prevent encrustation inside the pipe.



CLEANING THE VACUUM FILTER

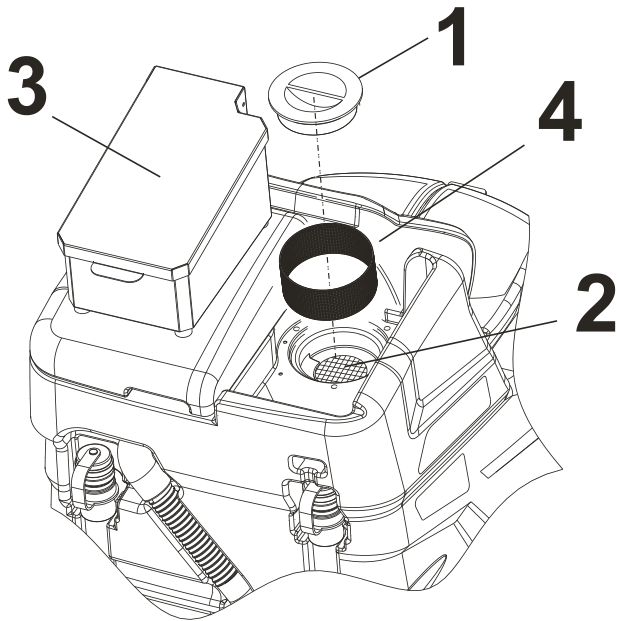

The machine is fitted with 2 stainless-steel mesh filters, a fix and a removable one, used to protect the vacuum motor. Weekly, or even daily for certain spaces, we suggest checking if filters are clean and if there is material that can block the aspiration. Follow the instructions below to clean the filter:

- Stop the machine in a flat area;
 - Turn off all the functions and remove the key;
 - Move the container of the battery charger pos.3, if present, above the cover of the recovery tank;
 - Unscrew and remove the cap (pos.1);
 - Remove and clean the removable filter (pos.4);
 - Clean the screen without removing it (pos.2);
 - Put the cap (pos. 1) back on and make sure to tighten it correctly.
- If the cap is not tightened properly, this may cause poor vacuum performance;
- Place again the container of the battery charger;



DRAINING AND CLEANING THE SOLUTION TANK

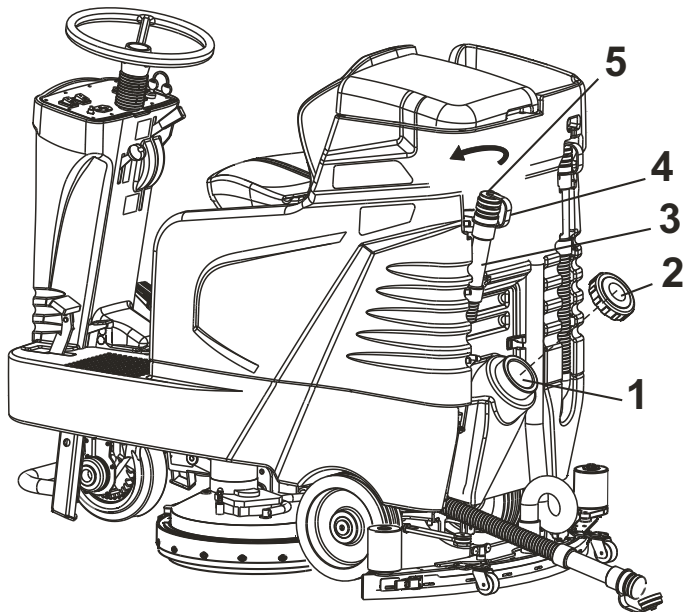

After completing the washing operation, in order to drain any leftover water from the solution tank and clean the tank, proceed as follows:

- Lift the brush plate and turn off the switch on the control panel;
- Lift the squeegee and turn off the switch on the control panel after 10 sec;
- Go to the provided area to drain the tank;
- Turn off the machine and remove the key;
- Remove the drain pipe (pos.4) from the clean water tank and while keeping the pipe vertically, remove the cap (pos.5) by turning it counter clockwise as indicated by the arrow. Part of the pipe is flexible (pos.3), allowing it to be squeezed to limit the water flow. Once the pipe is open, place it on the ground slowly;
- Remove the filling cap (pos.2) and wash the tank using a rubber hose. Try to direct the water flow towards the front part of the machine so as to clean it thoroughly;
- Once the washing operation is completed, close the cap (pos.2) and put the drain pipe (pos.4) back with the cap (pos.5) screwed into place;



CHECKING BRUSHES OR ABRASIVE DISCS

After using the machine, remove the brushes or discs following the instructions described above:

- Check the integrity of the brushes and replace them if worn (the length of the lower bristle should be 10 millimetres);
- Check the integrity of the abrasive discs and replace them if worn.



CLEANING THE SQUEEGEE

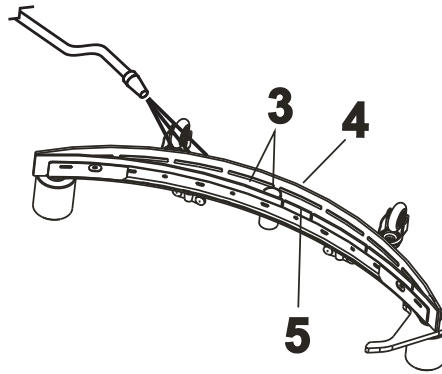
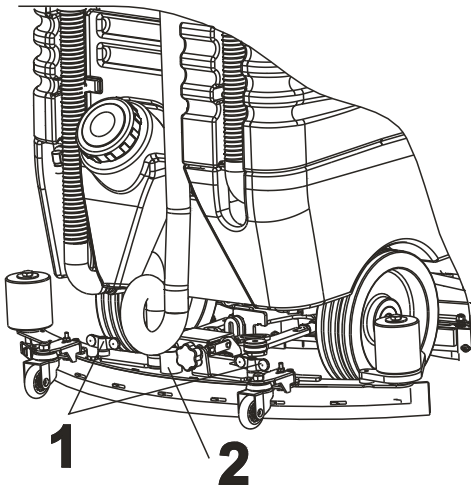

Once the washing operation is completed, clean the squeegee and check the integrity of the blades. Proceed as follows:

- Lift the brush plate and turn off the switch on the control panel;
- Lift the squeegee using the provided lever and turn off the switch on the control panel after 10 seconds;
- Stop the machine in a levelled area and turn the key to position 0;
- Unscrew both fixing knobs (pos.1) and remove the squeegee vacuum pipe (pos.2);
- Remove the squeegee; lay it on the ground facing up (as shown in the figure). Use water to wash and clean the lower part and the mouth of the squeegee (pos.3), removing any pieces or encrustations for better vacuum performance;
- Use a piece of cloth to wipe off the rear drying blade (pos.4) and the front drying blade (pos.5);
- Make sure the blades are in good condition and if necessary rotate them in order to have a new edge in contact with the floor.



REPLACING SQUEEGEE BLADES

The squeegee is fitted with two drying blades (a rear and a front blade) as specified in the previous paragraph. Each blade has 4 edges that can be used and rotated 4 times before being replaced, unless one of the edges is torn.

For better drying performance, make sure the edge of the rear blade in contact with the floor is not worn out. If the blade is worn out, rotate it or replace it.

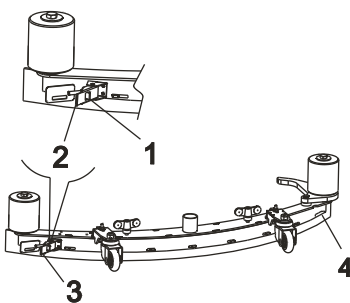

REPLACING THE REAR BLADE

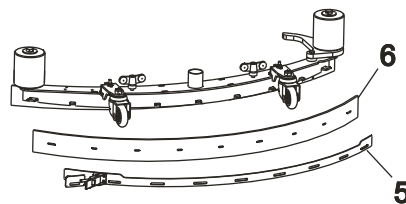

Follow the instructions below to rotate or replace the rear blade:

- Remove the squeegee from the machine;
- Remove the blade locking plate (pos.5) by unlocking the retainer (pos.3). This retainer is fitted with a safety device that keeps it from opening involuntarily. To release the retainer push the small lever (pos. 1) towards the outer part of the squeegee and pull the lever (pos. 2) towards the rear part of the squeegee;
- Remove the blade locking plate (pos.5) from the other end of the squeegee (pos.4);
- Remove the blade (pos.6);
- Rotate the blade and mount it back so that a new edge is on the drying side;
- Lock the locking plate (pos.4) and hook the retainer (pos.3) and lock it into place;
- By remounting the blade (6) please pay attention that the blade lays on the floor regularly and uniform in its entire length;

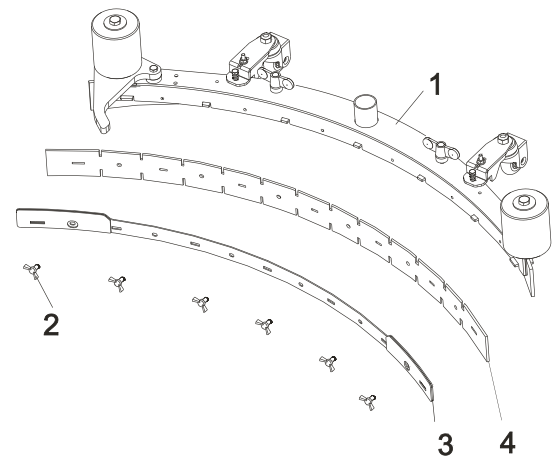

REPLACING THE FRONT BLADE

Follow the instructions below to replace the front blade:

- Remove the squeegee (pos.1) from the machine;
- Remove the wing screws (pos.2);
- Remove the blade locking plate (pos.3);
- Remove the blade (pos.4);
- If the external edge is in good condition, rotate the blade and mount it back so that a new edge is on the drying side; otherwise replace it with a new one;
- Put the blade locking plate back into place (pos.3);
- Put the wing screws (pos.2) back into place and check that the blade (pos.4) is regular and make sure not to tighten the screws excessively, causing the rubber blade to deform (swell);



REPLACING THE SPLASH GUARD BLADES

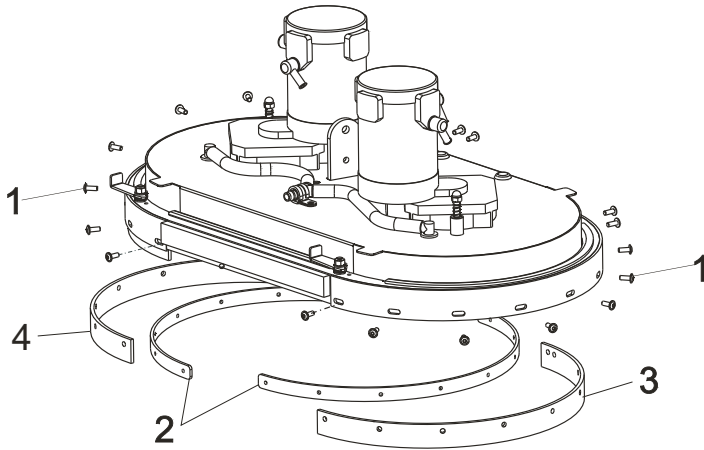

Follow the instructions below to replace the side blades of the splash guard:

- Lift the brush plate and turn off the switch on the control panel;
 - Turn off the machine and remove the key;
 - Use a 4mm hex wrench (pos. 1) to remove the screws;
 - Remove the internal blade locking plate (pos. 2);
 - Remove the blade pos. 3 or pos. 4 with a new one;
 - Put the rubber and the internal plate back into place using the screws (pos.1).
- Make sure that the rubber is equally distributed throughout its entire length;



CLEANING THE DETERGENT SOLUTION FILTER

The machine is fitted with a filter on the duct coming from the detergent solution tank. In theory, the solution in the tank should be free of impurities as the buckets or containers used to fill the solution must be clean. Follow the instructions below to clean the filter:

- Stop the machine in a levelled area, turn off the machine and remove the key;
- Close the valve using the lever (pos. 1);
- Use two hands to remove the clear cup (pos. 2);
- Remove the protective screen (pos. 3) and wash the cup and the screen with water;
- Put the cup (pos. 2) and the protective screen (pos. 3) on the fixed part of the filter (pos. 4), making sure that the protective screen is fitted correctly into its housing on the cup and in the support;
- Open the valve using the lever (pos. 1).

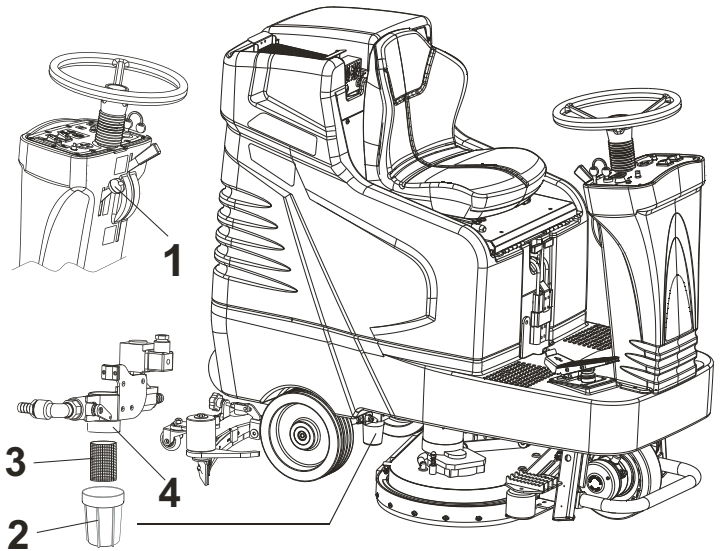

CHECKING THE GASKET ON THE COVER

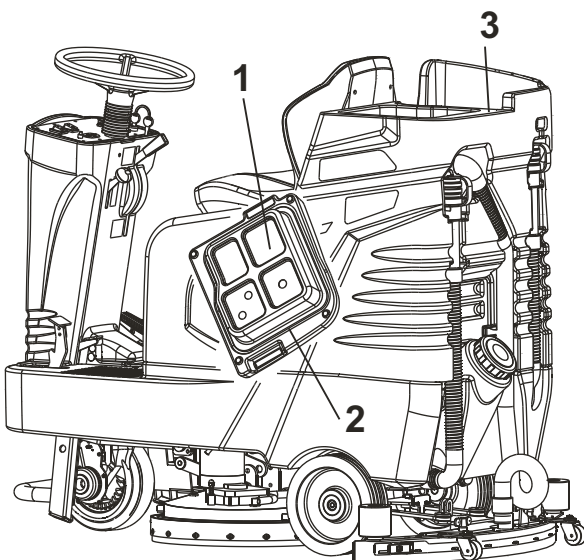

The gasket on the cover of the recovery tank seals the tank properly, providing a better vacuum performance on the squeegee. For this reason, it is very important to keep the gasket intact in order for the machine to work properly.

Follow the instructions below to clean and check the gasket:

- Open the cover (pos.1);
- Use a piece of cloth to wipe off the gasket (pos.2). Make sure it is not cut or damaged;
- If the gasket is damaged, remove it from its housing on the cover and mount a new gasket;
- Clean the area of the tank where the gasket rests (pos.3) when the cover is closed;



CHECKING OR REPLACING FUSES

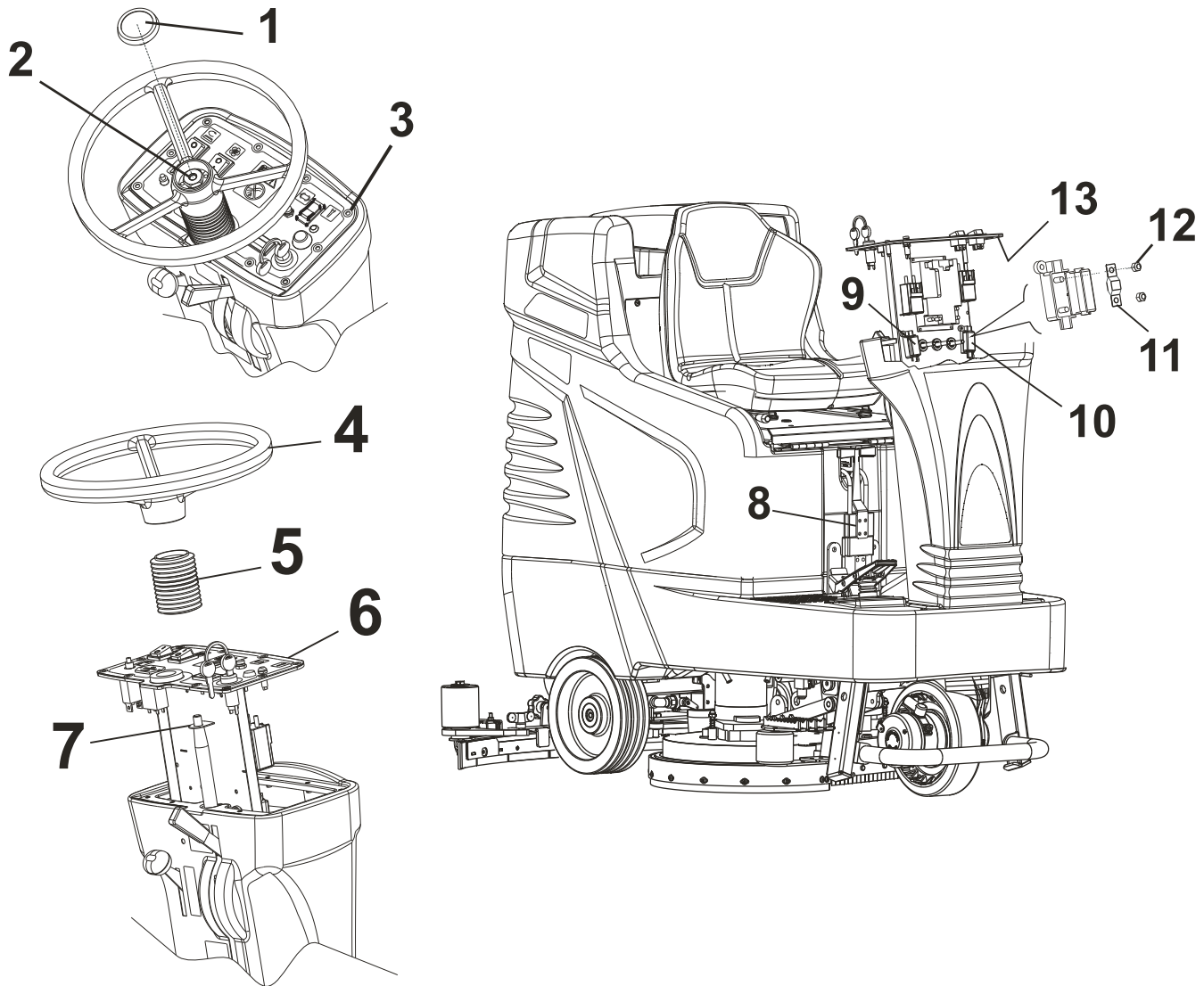

To check and replace fuses proceed as follows:

- Stop the machine in a levelled area and turn the key to position 0;
- Unplug the mobile connector (pos. 8) and remove the cap from the hand-wheel (pos.1);
- The hand-wheel (pos. 4) is fitted with a device designed for quick removal.

Use a 27mm wrench to unscrew the nut (pos. 2) until the hand-wheel is removed from its housing on the shaft;

- Remove the bellows (pos. 5);
- Use a 3mm Allen key to remove the 10 fixing screws (pos. 3) of the control panel;
- Remove the control panel (pos.6), lift it and attach it to the shaft of the wheel using the provided bracket (pos.7), ensuring not to jerk as this could damage the electrical system. From this position, the operator has access to all the components of the electrical system (remote switches, drive control board, control panel components, fuses, etc.);

- Fuse holder (pos. 10): 50A DRIVE SYSTEM PROTECTION fuse;

TO REPLACE IT PROCEED AS FOLLOWS:

- Open the fuse holder cover (pos. 10);
- Unscrew the 2 nuts (pos. 12) that hold the fuse;
- Replace the 50A fuse (pos. 11) with a fuse of equal amperage and with the same characteristics;
- Put the nuts back into place and close the cover of the fuse holder.

- Fuse holder (pos. 9): 30A VACUUM MOTOR PROTECTION fuse. To replace to carbon brushes, follow the instructions above;

- Put the control panel back inside the plastic end piece, ensuring not to jerk it as this could damage the electrical system;

- Put the screws (pos. 3) back into place and tighten them using the provided key so as to give good pressure on the gasket located beneath the panel

After checking or replacing the fuses, put everything back into place and resume the operation.

To mount the hand-wheel, align the key on the shaft with the housing located on the hand-wheel and screw the nut (pos. 2).



CHECKING OR REPLACING FUSES IN THE INSTRUMENT PANEL

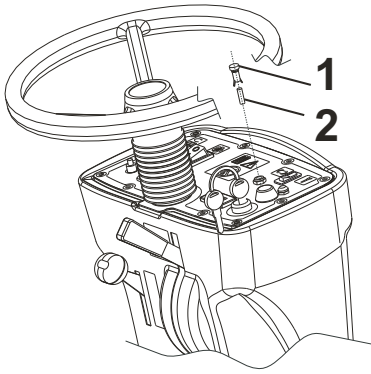

One 5A glass fuse used to protect the control panel instruments is mounted in the control panel. Follow the instructions below to check or replace the fuses:

- Unplug the battery connector;
- Do a 1/4 turn left on the cover of the fuse holder (pos.1) and remove it;
- The 5A glass fuse will also come out along with the cover;
- Check the fuse and if necessary replace it with one of equal amperage and with the same characteristics;
- Put the fuse and the cover in the fixed part of the fuse holder on the control panel, push and screw;
- Plug the battery connector back on;



CHECKING TO BE MADE EVERY 400 HOURS ON THE DRIVE WHEEL

DRIVE WHEEL

Check the motor carbon brushes and if necessary replace them when their length reaches 7 mm. Length of new motor brush: 20 mm.

Motor brush code: 640291, n°4 x motor.

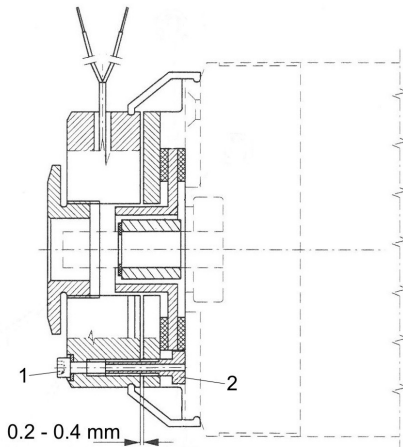
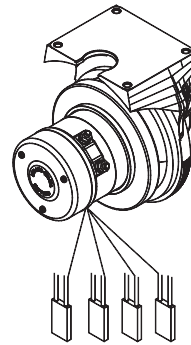

E65 TRAC M up to frame 650001790218
E75 TRAC M up to frame 750028050318
E83 TRAC M up to frame 830004350318

TELECO ELECTROBRAKE

- Check the correct functioning and that the following values are correct
 - Absorption 0.9 – 1.1 A
 - Ohmic resistance 22 – 25 Ω
- Check the play of the brake disc to be within: 0.2 - 0.4 mm; in case, adjust it
For the adjustment of the play:
 - Loosen the screws pos.1;
 - Adjust the bushings (by screwing / unscrewing them) pos.2 so as to get the play indicated.
 - Lock the screws pos.1;

Traction motor consumption: (with tyre lifted from the floor): 12 A

Traction motor consumption: (running on the floor) 18 A. This value has been obtained with two 0.6mm ppl brushes and machine running at the maximum speed, full tank (87 l). Flat and smooth floor (no slopes), men on board and 4 x 6V 180Ah C5 batteries.

IP65 PREC. ELECTROBRAKE (EUREKA CODE 490843)

Check the correct functioning and that the following values are correct:

- Absorption ≈ 1.17 A;
- Ohmic resistance 20 – 22 Ω;
- Brake lining minimum size 4.5 mm (brand new one measures 5 mm);

Tightening torque of the 3 screws = 3 Nm

Traction motor consumption: (with tyre lifted from the floor): 13-14 A

Traction motor consumption: (running on the floor) 25-29 A. This value has been obtained with two 0.6mm ppl brushes and machine running at the maximum speed, full tank (87 l). Flat and smooth floor (no slopes), men on board and 4 x 6V 180Ah C5 batteries.

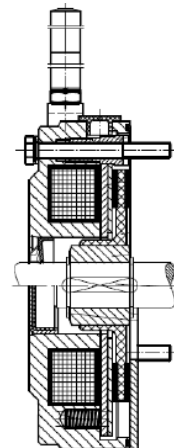

DIMENSIONAL TECHNICAL DRAWINGS

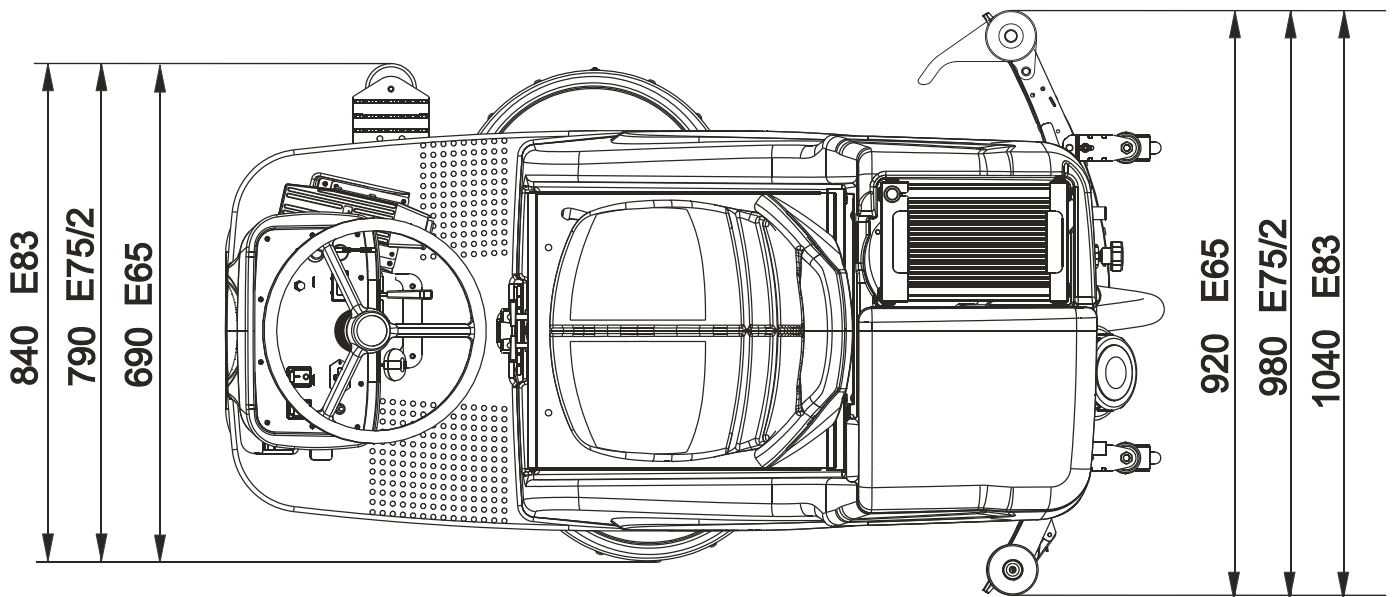
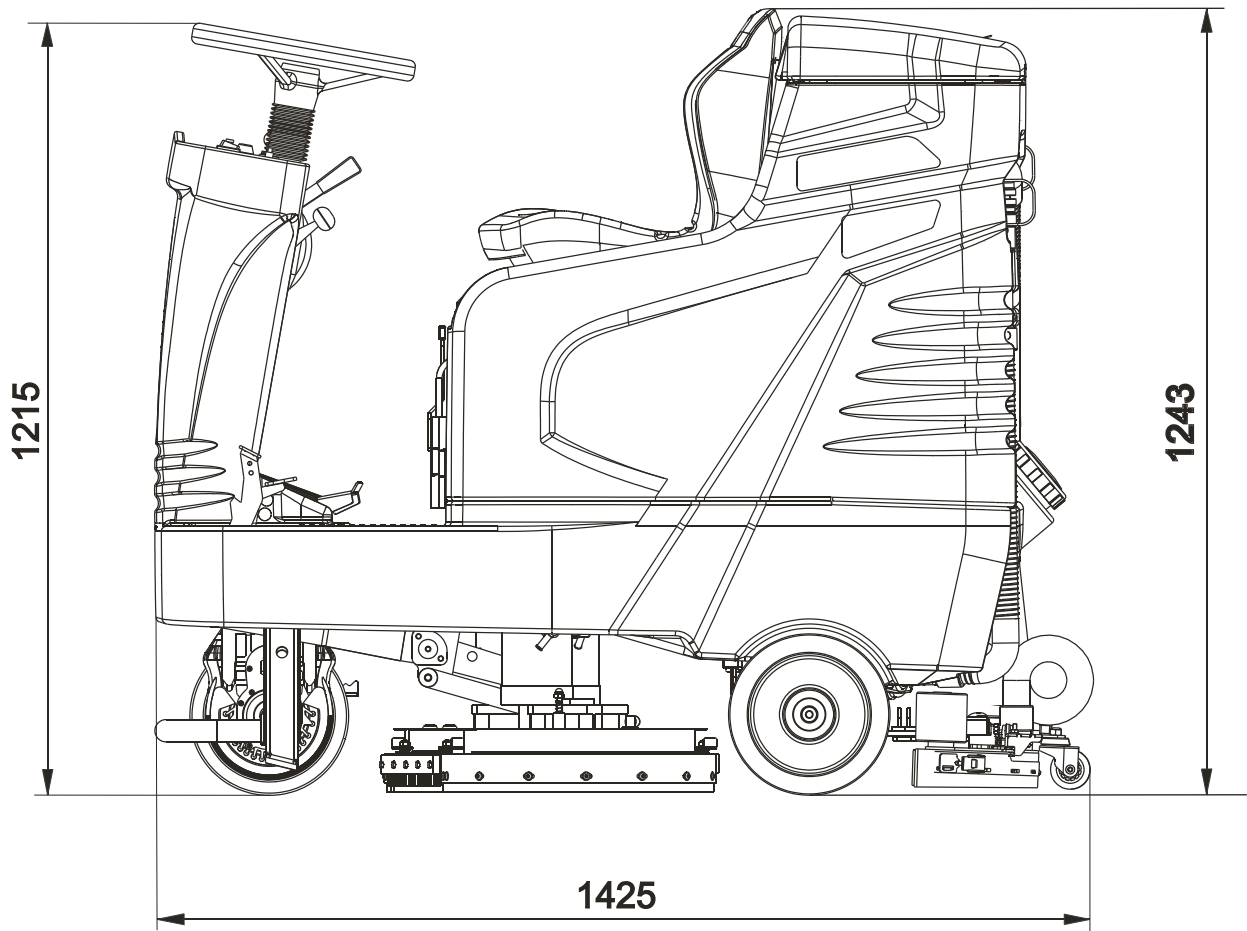

TECHNICAL CHART

TECHNICAL SPECIFICATIONS		E65 TRAC M	E75 TRAC M	E83 TRAC M
MAIN SPECIFICATIONS	Cleaning path	650 mm	760 mm	830 mm
	Hourly performance	3.900 m ² /h	4.560 m ² /h	4.980 m ² /h
	Solution tank capacity	110 L		
	Recovery tank capacity	125 L		
	Forward speed	0 - 6 km/h		
	Maximum gradient	20 %		
	Turning radius	1.560 mm		
DIMENSIONS AND WEIGHT	Dimensions (without squeegee)	1.425 x 690 x 1.243 mm	1.425 x 790 x 1.243 mm	1.425 x 840 x 1.243 mm
	Width (with squeegee)	920 mm	980 mm	1.040 mm
	Weight	221 kg	228 kg	235 kg
	Weight (with type A batteries)	351 kg	358 kg	365 kg
	Weight (with type B batteries)	345 kg	352 kg	359 kg
	Packaging dimensions	1.630 x 900 x 1.420 mm		
	Packaging weight	39 kg		
	Packaging volume	2,08 m ³		
BRUSHES	Brush dimensions	Ø 305 - 330 mm	Ø 355 - 380 mm	Ø 380 - 415 mm
	Pad size (only with pad holder)	330 mm / 13"	381 mm / 15"	406 mm / 16"
	Brush motor	Gear motor: 24V - 400 W - 20A - 190 RPM - IP 20		
TRACTION SYSTEM	Traction type	Forward and reverse traction via front drive wheel, electronically controlled		
	Traction motor	24V - 900 W - 46 A		
	Front wheel RPM (machine unloaded)	110 - 120 RPM		
BATTERIES	Batteries	4 x 6 V		
	Battery tray dimensions	531 x 385 x 290 mm		
TYPE A BATTERIES	Type	4 lead acid batteries 6V 240A (20H) - 180A (5H)		
	Dimensions ea.	242 x 190 x 285 mm		
	Weight (with acid) ea.	32,6 kg		
	Autonomy (theoretical)	4 h	4 h	3 h 30 min
TYPE B BATTERIES	Type	4 gel batteries 6V 180A (5H)		
	Dimensions ea.	242 x 190 x 285 mm		
	Weight (with acid) ea.	31 kg		
	Autonomy (theoretical)	3 h 45 min	3 h 45 min	3 h 15 min

TECHNICAL SPECIFICATIONS		E65 TRAC M	E75 TRAC M	E83 TRAC M
BATTERY CHARGER	Model	24V - 30 A (220 - 240 Volt 50/60 Hz input voltage)		
	Settings	Calibrated for lead acid, AGM / gel, or gel Sonnenschein batteries The setting can be subsequently changed by purchasing a programmer		
SOLUTION FLOW	Solution control	Manual control for solution flow + solenoid valve		
	Flow rate	0 - 3,5 L/min		
VACUUM SYSTEM	Vacuum motor	3 stage - 24V - 550 W - 25 A		
	Water pick up	1.250 mm/H ₂ O		
	Standard filter	Stainless steel mesh		
WHEELS	Front wheel	Ø 250 x 102 mm - solid rubber, super elastic, non-marking and oil resistant Hub made of aluminium coated in non-slip polyurethane		
	Rear wheels	Ø 250 x 80 mm - solid rubber, super elastic, non-marking and oil resistant. Hub made of nylon coated in polyurethane		
	Brakes	Electromagnetic with manual lever		
SOUND LEVEL (UNI EN ISO 11201)	Noise emission value LpA	72 dB (A)		
	Uncertainty KpA	2.4 dB (A)		
VIBRATION LEVEL	Whole-body vibration level aW	0.53 m/s ²		
	Uncertainty K	0.27 m/s ²		
TEMPERATURE RATING	Storage temperature	+5 / +40 °C		
	Operating temperature	+5 / +40 °C		

SERVICE AND MAINTENANCE RECORDS

1°

SERVICE AND MAINTENANCE RECORD

TO 100 HOURS

DATE

DAY	MONTH	YEAR	WORKING HOURS

- Check that the battery clamps are not loosen or oxidized
- Check the batteries fluid level
- Check the cover gasket
- Check the vacuum motor filter
- Check the brake
- Check, and if necessary replace, the fuses
- Check the brushes and the components of the brush plate
- Check, and if necessary rotate or replace, the squeegee blades
- Check the adjusting/closing detergent solution tap
- Check the detergent solution filter (located just before the pump)
- Check the pump, the solenoid valve and the fitting outgoing from the pump
- Check that the vacuum pipe on the squeegee and the drainpipes of the solution and recovery tanks are not broken or clogged
- Check the actuators of the squeegee and the brush plate (anyway if actuators have problems, they will be detected by the control board)
- Lubricate the squeegee pivot pin
- Test the machine in all its operating functions

THE SERVICE WAS CARRIED OUT ON:

NAME:

SURNAME:

SIGNATURE:

STAMP OF DEALER WHO CARRIED OUT SERVICE

NOTES

2°

SERVICE AND MAINTENANCE RECORD

TO 200 HOURS

DATE

DAY	MONTH	YEAR	WORKING HOURS

- Check that the battery clamps are not loosen or oxidized
- Check the batteries fluid level
- Check the cover gasket
- Check the vacuum motor filter
- Check the brake
- Check, and if necessary replace, the fuses
- Check the brushes and the components of the brush plate
- Check, and if necessary rotate or replace, the squeegee blades
- Check the adjusting/closing detergent solution tap
- Check the detergent solution filter (located just before the pump)
- Check the pump, the solenoid valve and the fitting outgoing from the pump
- Check that the vacuum pipe on the squeegee and the drainpipes of the solution and recovery tanks are not broken or clogged
- Check the actuators of the squeegee and the brush plate (anyway if actuators have problems, they will be detected by the control board)
- Lubricate the squeegee pivot pin
- Test the machine in all its operating functions

THE SERVICE WAS CARRIED OUT ON:

NAME:

SURNAME:

SIGNATURE:

STAMP OF DEALER WHO CARRIED OUT SERVICE

NOTES

3°

SERVICE AND MAINTENANCE RECORD

TO 300 HOURS

DATE

DAY	MONTH	YEAR	WORKING HOURS

- Check that the battery clamps are not loosen or oxidized
- Check the batteries fluid level
- Check the cover gasket
- Check the vacuum motor filter
- Check the brake
- Check, and if necessary replace, the fuses
- Check the brushes and the components of the brush plate
- Check, and if necessary rotate or replace, the squeegee blades
- Check the adjusting/closing detergent solution tap
- Check the detergent solution filter (located just before the pump)
- Check the pump, the solenoid valve and the fitting outgoing from the pump
- Check that the vacuum pipe on the squeegee and the drainpipes of the solution and recovery tanks are not broken or clogged
- Check the actuators of the squeegee and the brush plate (anyway if actuators have problems, they will be detected by the control board)
- Lubricate the squeegee pivot pin
- Test the machine in all its operating functions

THE SERVICE WAS CARRIED OUT ON:

NAME:

SURNAME:

SIGNATURE:

STAMP OF DEALER WHO CARRIED OUT SERVICE

NOTES

4°

SERVICE AND MAINTENANCE RECORD

TO 400 HOURS

DATE

DAY	MONTH	YEAR	WORKING HOURS

- Check that the battery clamps are not loosen or oxidized
- Check the batteries fluid level
- Check the cover gasket
- Check the vacuum motor filter
- Check the brake
- Check, and if necessary replace, the fuses
- Check the brushes and the components of the brush plate
- Check, and if necessary rotate or replace, the squeegee blades
- Check the adjusting/closing detergent solution tap
- Check the detergent solution filter (located just before the pump)
- Check the pump, the solenoid valve and the fitting outgoing from the pump
- Check that the vacuum pipe on the squeegee and the drainpipes of the solution and recovery tanks are not broken or clogged
- Check the actuators of the squeegee and the brush plate (anyway if actuators have problems, they will be detected by the control board)
- Lubricate the squeegee pivot pin
- Test the machine in all its operating functions

THE SERVICE WAS CARRIED OUT ON:

NAME:

SURNAME:

SIGNATURE:

STAMP OF DEALER WHO CARRIED OUT SERVICE

NOTES

5°

SERVICE AND MAINTENANCE RECORD

TO 500 HOURS

DATE

DAY	MONTH	YEAR	WORKING HOURS

CHECK AND REMOVE THE MOTOR CARBON BRUSHES ONE AT A TIME SO AS NOT TO INVERT THEM. THE MOTOR CARBON BRUSHES SETTLE AND WEAR DIFFERENTLY THE ONE FROM THE OTHER, CONSEQUENTLY IF THESE ARE INSPECTED AND PUT BACK ON AGAIN BECAUSE THEY ARE NOT FULLY WORN, THEY MUST BE REFITTED IN THE SAME POSITION.

VACUUM MOTOR

Check the carbon brushes and replace them if they are shorter than 10 mm. Length of new motor carbon brush: 26.8 mm.

N°2 carbons (cod 640337) for each motor;

BRUSHES MOTOR E65 TRAC M - E75 TRAC M

Check the carbon brushes and replace them if they are shorter than 12 mm. Length of new motor carbon brush: 24 mm.

N°2 carbons (cod 640258) for each motor, n°2 carbons (cod 640259) for each motor;

BRUSHES MOTOR E83 TRAC M

Check the carbon brushes and replace them if they are shorter than 11.5 mm. Length of new motor carbon brush: 19 mm.

N°4 carbons (cod 640281) for each motor (1 kit);

MOTORWHEEL

Check the carbon brushes and replace them if they are shorter than 7 mm. Length of new motor carbon brush: 20 mm.

N°4 carbons (cod 640291) for each motor. Check also the motor oil level in the motorwheel.

- Check that the battery clamps are not loosen or oxidized
- Check the batteries fluid level
- Check the cover gasket
- Check the vacuum motor filter
- Check the brake
- Check, and if necessary replace, the fuses
- Check the brushes and brush plate components
- Check, and if necessary rotate or replace, the squeegee blades
- Check the adjusting/closing detergent solution tap
- Check the detergent solution filter (located just before the pump)
- Check the pump, the solenoid valve and the fitting outgoing from the pump
- Check the recovery tank and solution drain lines
- Check that the vacuum pipe on the squeegee and the drainpipes of the solution and recovery tanks are not broken or clogged
- Check the wheel bearings
- Check the correct operation of the electric brake and the brake disc
- Lubricate the squeegee pivot pin
- Test the machine in all its operating functions

THE SERVICE WAS CARRIED OUT ON:

NAME:

SURNAME:

SIGNATURE:

STAMP OF DEALER WHO CARRIED OUT SERVICE

NOTES

UP TO 600 HOURS AS FOR 100 HOURS	DATE	DAY	MONTH	YEAR	WORK. HOURS
THE SERVICE WAS CARRIED OUT ON:		STAMP OF DEALER WHO CARRIED OUT SERVICE			
NAME:					
SURNAME:					
SIGNATURE:					

UP TO 700 HOURS AS FOR 200 HOURS	DATE	DAY	MONTH	YEAR	WORK. HOURS
THE SERVICE WAS CARRIED OUT ON:		STAMP OF DEALER WHO CARRIED OUT SERVICE			
NAME:					
SURNAME:					
SIGNATURE:					

UP TO 800 HOURS AS FOR 300 HOURS	DATE	DAY	MONTH	YEAR	WORK. HOURS
THE SERVICE WAS CARRIED OUT ON:		STAMP OF DEALER WHO CARRIED OUT SERVICE			
NAME:					
SURNAME:					
SIGNATURE:					

UP TO 900 HOURS AS FOR 400 HOURS	DATE	DAY	MONTH	YEAR	WORK. HOURS
THE SERVICE WAS CARRIED OUT ON:		STAMP OF DEALER WHO CARRIED OUT SERVICE			
NAME:					
SURNAME:					
SIGNATURE:					

UP TO 1000 HOURS AS FOR 500 HOURS	DATE	DAY	MONTH	YEAR	WORK. HOURS
THE SERVICE WAS CARRIED OUT ON:		STAMP OF DEALER WHO CARRIED OUT SERVICE			
NAME:					
SURNAME:					
SIGNATURE:					

NOTES

TROUBLE-SHOOTING CHART

WARNING!

ANY TYPE OF SERVICE OPERATION OR TEST, WITH THE EXCEPTION OF THOSE SHOWN IN THE ENGINE'S MANUAL OR THE BATTERY'S MANUAL, MUST BE CARRIED OUT BY AUTHORIZED SERVICE CENTRES ONLY.

BEFORE ANY INTERVENTIONS CHECK THE CORRECT VOLTAGE OF THE BATTERY: 24V		
PROBLEM	CAUSE	SOLUTION
The battery does not charge	Faulty or worn elements	Replace the battery
The instruments on the panel do not work when placing the key	Low Battery	Recharge the battery
	Burnt fuse	Replace the fuse
	Battery connector unplugged	Plug the battery connector
	Faulty ignition key	Replace the key
	On-board battery charger: Faulty internal remote switch	Replace the battery charger
	On-board battery charger: Machine charging	Unplug the battery charger from the mains
The brush motor is not spinning	Low battery	Recharge the battery
	Faulty electric motor remote switch	Replace the electric motor remote switch
	Faulty brush switch	Replace the brush switch
	Carbon contacts worn out	Replace the contacts
	30A magnetothermic circuit breaker engaged	Reset the magnetothermic circuit breaker
	Faulty motor	Replace the motor
	Brush plate lifted	Lower the brush plate
	Faulty micro-switch on the brush plate	Replace the micro-switch
	Locked or damaged electrobrake	Check the correct functioning and the absorptions
	Faulty traction board	Replace the traction board
The drive will not work	Low Battery	Recharge the battery
	Seat safety engaged	Sit down
	Key not inserted	Insert the key
	Faulty 50A drive system protection fuse	Replace the fuse
	Faulty drive wheel	Replace or repair the drive wheel
	Locked or damaged electrobrake	Check the correct functioning and the absorptions
	Drive wheel carbon contacts worn out	Replace the contacts
	Fault electronic control	Replace the electronic control
	Fault pedal control	Replace or repair the pedal control

TRACTION BOARD FORWARD MOVEMENT: INDICATOR LIGHT FLASHING DIAGNOSTICS

UP TO FRAME 65000237 - 75003151 - 83000720

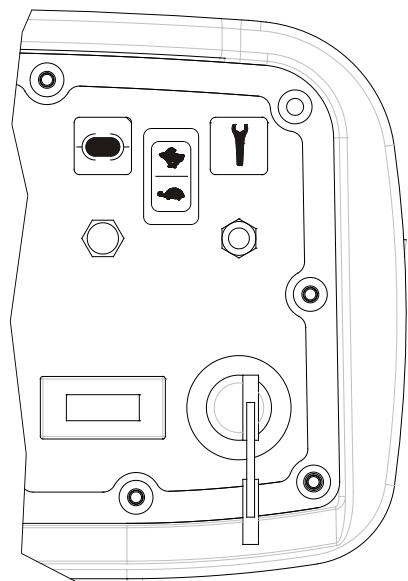

OFF: NO ERROR, NORMAL CONDITION

1 FLASH: forward movement micro on at switch-on	<ul style="list-style-type: none"> • Move the pedal to zero position • Make sure the pedal returns precisely to zero
2 FLASHES: reverse movement micro on at switch-on	<ul style="list-style-type: none"> • Check the microswitch on the pedal
3 FLASHES: interruption of potentiometer signal	Check the potentiometer cables
4 FLASHES: potentiometer not idle at switch-on	<ul style="list-style-type: none"> • Move the pedal to zero position • Make sure the control returns precisely to zero • Check the potentiometer on the forward movement pedal
5 FLASHES: - Thermal protection - Locked or damaged electrobrake	<ul style="list-style-type: none"> • Stop the machine, wait for several minutes and start the machine • Check the power draw of the motor • Check the correct functioning and the absorptions
6 FLASHES: - Power fuse damaged - Power stage damaged	<ul style="list-style-type: none"> • Make sure the 50A power fuse from the battery + to the drive unit is OK and that the battery and motor cables are correctly connected • Replace the traction board
7 FLASHES: overcurrent	The cables from the battery to the traction board or from the traction board to the motor are loose, oxidized or not correctly connected. Check the cables
8 FLASHES: - Fuse or internal relay damaged - Locked or damaged electrobrake	<ul style="list-style-type: none"> • Make sure that the 50A fuse from the + battery works correctly upon ignition and the battery cables and motor cables are connected correctly. If the problem persists, replace the traction board. • Check the correct functioning and the absorptions
9 FLASHES: undervoltage (< 19 V)	Check and charge the batteries
10 FLASHES: overvoltage	Battery voltage above 45V
11 LAMPEGGI: - Amperometric protection of the traction motor - Locked or damaged electrobrake	<ul style="list-style-type: none"> • The motor has worked for more than 10 seconds above the maximum nominal current value (15 A). Verify that the motor/wheel spins freely. Check with an amp meter the motor consumption. For the correct consumption values refer to the technical chart. • Check the correct functioning and the absorptions
13 FLASHES: temporary power supply interruption The traction board power supply could drop down below 19V, with batteries almost discharged, when the main brush gets activated for example	<p>Attention! If 13 flashes appear, the operator should first ensure that at least 3-4 seconds have passed between turning off the machine (key in position 0) and turning on the machine (key in position 1). This is the time required for the traction electronic card to activate. Otherwise 13 flashes are generated. If the problem persists it could be a bad electrical contact issue: check that in the ignition switch, fuses and the 16 poles connector of the chopper there isn't any intermittent contact. If the problem persists again replace the chopper. Charge the batteries and repeat the test with machine running and main brush activated.</p>
14 FLASHES: data reading failure	Remove the key and move the forward movement control to idle. If the problem continues, replace the traction board.

TRACTION BOARD FORWARD MOVEMENT: INDICATOR LIGHT FLASHING DIAGNOSTICS

FROM FRAME 65000238 - 75003152 - 83000721

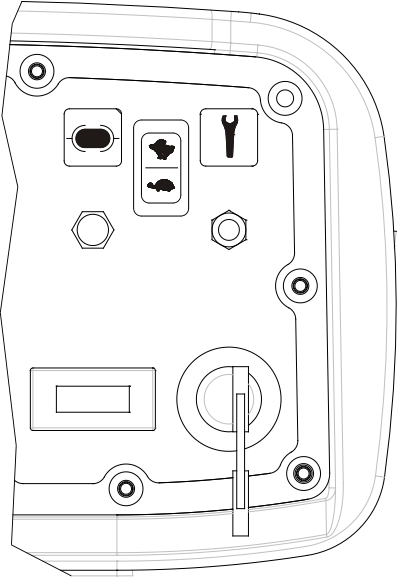
	Example of count flashes: ●●_●●●_●●_●●●_●●_●●●_etc.= 2+3 flashes		
	ALWAYS ON: NO ERROR, NORMAL CONDITION		
	1+2 FLASHES: overcurrent	<ul style="list-style-type: none"> ● The cables from the battery to the traction board or from the board to the motor are loose, oxidized or not correctly connected ● Check the cables ● Cycle the keyswitch 	
	1+3 FLASHES: current sensor. The controller's current sensors have invalid offset readings	<ul style="list-style-type: none"> ● Cycle the keyswitch ● Replace the traction board 	
	1+5 FLASHES: controller severe undertemperature. The heatsink temperature is below -40°C	<ul style="list-style-type: none"> ● Raise the heatsink temperature to above -40°C ● Cycle the keyswitch 	
	1+6 FLASHES: controller severe overtemperature. The heatsink temperature is above 85°C	<ul style="list-style-type: none"> ● Decrease the heatsink temperature to below 85°C ● Cycle the keyswitch 	
	1+7 FLASHES: B+ Undervoltage ● Battery voltage below 19V	<ul style="list-style-type: none"> ● Charge the battery ● Check battery terminal ● Cycle the keyswitch 	
	1+9 FLASHES: B+ Overvoltage ● Battery voltage above 28.8V	<ul style="list-style-type: none"> ● Check that the battery installed is 24V ● Cycle the keyswitch 	
	2+3 FLASHES: Speed reduction due to controller temperature too high. Heatsink temperature exceeds 75 °C ● The controller is operating in an extremely hot environment ● There is excessive load on the vehicle ● The controller is incorrectly mounted	<ul style="list-style-type: none"> ● Return the machine in the field of acceptable temperature ● Check absorption of the drive wheel ● Check the mounting of the controller ● Cycle the keyswitch 	
	2+4 FLASHES: Speed reduction due to too low battery voltage	<ul style="list-style-type: none"> ● Charge the battery ● Check battery terminal ● Cycle the keyswitch 	
	3+1 FLASHES: Electrobrake stop	<ul style="list-style-type: none"> ● Check the wiring and the terminals ● Check the solenoid valve ● Check the brush contactor ● Switch the machine off and on again 	
	3+7 FLASHES: The motor phase is open	<ul style="list-style-type: none"> ● Check the crimps and wiring M1-M2 ● Check the wheel drive wiring ● Cycle the keyswitch 	
	3+9 FLASHES: Blown B+ fuse	<ul style="list-style-type: none"> ● Replace the fuse ● Check the wiring and the B + fuse ● Check the key block 	
	4+4 FLASHES: Sequence error at power up. Forward / reverse microswitch inserted or potentiometer not idle at switch-on	<ul style="list-style-type: none"> ● Move the pedal to zero position ● Make sure the pedal returns precisely to zero ● Check the microswitch on the pedal ● Cycle the keyswitch 	
	5+8 FLASHES: The motor has stalled	<ul style="list-style-type: none"> ● Identify the possible causes of the stall ● Cycle the keyswitch ● Check the electric brake 	
8+8 FLASHES: An internal controller fault occurred	<ul style="list-style-type: none"> ● Cycle the keyswitch ● If it persists, replace the controller 		
11+8 FLASHES: The controller did not power up correctly	<ul style="list-style-type: none"> ● Check connections ● Cycle the keyswitch ● If it persists, replace the controller 		
11+11 FLASHES: motor short	<ul style="list-style-type: none"> ● Check the crimps and wiring M1-M2 ● Check the wheel drive wiring ● Cycle the keyswitch 		

GUASTO	CAUSA	SOLUZIONE
Little or no detergent solution flow on the brush	Closed valve	Open the valve
	Faulty detergent solution solenoid valve	Replace the solenoid valve
	Detergent solution filter clogged	Clean the filter
	The solution duct going from the tank to the brush is clogged.	Make sure that there is no encrustation
The vacuum motor does not work	Faulty vacuum motor switch	Replace the switch
	Recovery tank full, floater engaged	Empty the tank
	Faulty floater	Replace the floater
	Low Battery	Recharge the battery
	Faulty 30A vacuum motor fuse	Replace the fuse
	Unplugged vacuum motor	Check the motor wiring
	Faulty vacuum motor	Replace the vacuum motor
	Vacuum motor carbon contacts worn out	Replace the contacts
When you start the vacuum motor, it works for 6/7 seconds, then it stops	Faulty floater	Clean the floater
	Dirty or blocked floater	Replace the floater
	Recovery tank full, floater engaged	Empty the tank
Poor suction on the squeegee	The recovery tank is full	Empty the tank
	Cap on the drain pipe of the tank is open	Tighten the cap correctly
	The vacuum pipe is not connected properly	Make sure it is mounted correctly
	Suction duct clogged	Clean the suction pipe
	Damaged suction pipe	Replace the pipe
	Dirty squeegee	Clean the squeegee
	Incorrect squeegee adjustment	Adjust the inclination and the pressure
	Matter trapped on the squeegee's blades	Clean the blades
	Worn or broken squeegee blades	Rotate the squeegee blades or replace them
	Tank cover open or closed incorrectly	Close or check the cover
	Damaged cover gasket	Replace the gasket
	Damaged or faulty vacuum motor	Replace or check the motor
	Low Battery	Recharge the battery
	Filter inspection cap not present or tightened incorrectly	Position and tighten the cap correctly
	Damaged gasket on the vacuum filter inspection cap	Check the gasket and replace it if necessary
Vacuum filter clogged	Clean the filter	
Battery charger flashing troubleshooting	Flashing troubleshooting: 1) STOP AND CHARGE LED FLASHING: Overheating 2) Battery defective or wrong voltage 3) STOP AND CHARGE LEDS TURNED ON FIXED: Charger failure	1) Make sure that the hood is open during charging and that the vents are not obstructed 2) Check voltage and battery status 3) Replace charger

EU DECLARATION OF CONFORMITY

according to Annex II A of the Machinery Directive 2006/42/CE

The manufacturer that places this product on the market:

EUREKA S.p.A. Unipersonale
VIALE DELL'ARTIGIANATO 30/32, 35013 CITTADELLA (PD) - ITALY

formally declares that the product:

Scrubber E65 TRAC M
Scrubber E75/2 TRAC M
Scrubber E83 TRAC M

complies with the following EU Directives:

2006 / 42 / CE
2014 / 30 / UE
2014 / 35 / UE
2011/ 65 / UE + 2015 / 863
2009 / 125 / CE

Machinery Directive, Annex 1
Electromagnetic Compatibility (EMC) Directive
Low Voltage Directive
RoHS 3 Directive
Energy-Related Products (ErP) Directive

The following harmonised and technical standards have been applied:

EN ISO 12100:2010	Safety of machinery - General principles for design - Risk assessment and risk reduction.
EN 60335-1:2013	Household and similar electrical appliances - Safety - Part 1: General requirements.
EN 60335-2-72:2016	Household and similar electrical appliances - Safety - Part 2: Particular requirements for floor treatment machines with or without traction drive, for commercial use.
EN 55014-1:2019	Electromagnetic compatibility - Requirements for household appliances - electric tools and similar apparatus - Part 1: Emission.
EN 55014-2:2015	Electromagnetic compatibility - Requirements for household appliances, electric tools and similar apparatus - Part 2: Immunity - Product family standard.
EN 61000-6-2:2016	Electromagnetic compatibility (EMC) - Part 6-2: Generic standards - Immunity standard for industrial environments.
EN 61000-6-4:2018	Electromagnetic compatibility (EMC) - Part 6-4: Generic standards - Emission standard for industrial environments.
EN 62233:2008	Measurement methods for electromagnetic fields of household appliances and similar apparatus with regard to human exposure.

Legal representative and person authorized to compile the technical file: Antonio Barile

Cittadella, 15/12/2023

EUREKA S.p.A
(Legal representative)

