

# INSTRUCTION MANUAL

## E71 TRAC TRONIC - E71 ECO

## E81 TRAC TRONIC - E81 ECO



EN

Instruction manual  
(Original instruction)



Attention: Read the instruction before use  
the machine





# CONTENT INDEX

<b>PRESENTATION</b> .....	<b>4</b>
<b>MACHINE IDENTIFICATION</b> .....	<b>5</b>
<b>GENERAL WARNINGS AND ADVICE</b> .....	<b>6</b>
<b>CLEANING AND MAINTENANCE</b> .....	<b>7</b>
<b>TRANSPORT</b> .....	<b>8</b>
<b>DISPOSAL</b> .....	<b>8</b>
<b>UNPACKING</b> .....	<b>9</b>
<b>MACHINE DESCRIPTION</b> .....	<b>12</b>
<b>MAIN FUNCTIONS AND CONTROLS</b> .....	<b>14</b>
<b>SETTING UP THE MACHINE</b> .....	<b>18</b>
ADJUSTING THE SQUEEGEE .....	18
MOUNTING THE SQUEEGEE .....	18
ADJUSTING THE SQUEEGEE OSCILLATING.....	19
MOUNTING THE BRUSH OR ABRASIVE DISC ON MACHINE .....	19
MOUNTING THE ABRASIVE DISC ONTO THE DISC PAD HOLDER.....	19
ADJUSTING THE QUANTITY OF SOLUTION ON THE BRUSHES (WATER + DETERGENT) .....	20
FILLING THE DETERGENT SOLUTION TANK .....	20
<b>USING THE MACHINE</b> .....	<b>21</b>
CHECK BEFORE USE.....	21
OPERATION.....	21
<b>MAINTENANCE</b> .....	<b>22</b>
DRAINING AND CLEANING THE RECOVERY TANK.....	22
CLEANING INSTRUCTIONS ECO-SYSTEM.....	23
CHECKING BRUSHES OR ABRASIVE DISCS.....	23
DRAINING AND CLEANING THE SOLUTION TANK.....	23
CLEANING THE DETERGENT SOLUTION FILTER .....	24
CLEANING THE SQUEEGEE .....	24
CLEANING THE PUMP OUTPUT PIPE FITTING (ECO).....	24
CHECKING THE INSTALLATION OF THE SQUEEGEE BLADES .....	25
REPLACING SQUEEGEE BLADES.....	25
CHECKING THE BRUSH PLATE SPLASHGUARD.....	26
CLEANING THE SUCTION FILTER.....	26
CHECKING OR REPLACING FUSES IN THE FRONT SWITCHBOARD .....	27
CHECKING OR REPLACING FUSES IN THE INSTRUMENT PANEL.....	28
CHECK THE SEAL ON THE COVER .....	29
RECHARGING BATTERIES.....	29
<b>DIMENSIONAL TECHNICAL DRAWINGS</b> .....	<b>30</b>
<b>TECHNICAL CHART</b> .....	<b>32</b>
<b>SERVICE AND MAINTENANCE RECORDS</b> .....	<b>36</b>
<b>TROUBLE-SHOOTING CHART</b> .....	<b>42</b>
<b>EU DECLARATION OF CONFORMITY</b> .....	<b>46</b>

# PRESENTATION

*Our company, a leader in the production of industrial cleaning machines, is delighted to have you among the owners of this scrubber and is sure you will be fully satisfied with it. We are sure that during its use, you will see the quality, robustness and possibilities of use it has to offer. This scrubber is suitable for private, industrial or public use. This manual describes the various installation operations, controls and maintenance interventions necessary to maintain perfect efficiency of your scrubber. These are normal maintenance operations that any operator can carry out using devices normally available in a company. For particular works, please contact specialist staff.*

OUR COMPANY AIMS TO CONSTANTLY IMPROVE ITS PRODUCTS AND RESERVES THE RIGHT TO MAKE CHANGES AND IMPROVEMENTS WHEN NECESSARY WITHOUT ANY OBLIGATION TO UPGRADE PREVIOUSLY SOLD MACHINES.

## ATTENTION!

### **THE MACHINE IS NOT CERTIFIED FOR ON-ROAD USE.**

BEFORE USING THE MACHINE OR CARRYING OUT ANY OPERATION ON IT, ALL THE PROCEDURES AND WARNINGS DESCRIBED IN THIS MANUAL MUST BE READ AND UNDERSTOOD. STRICT COMPLIANCE WITH THE REGULATIONS AND THE INSTRUCTIONS CONTAINED IN THIS MANUAL, COMBINED WITH THE OPERATOR'S ATTENTION AND CAUTION, WILL BE THE BEST GUARANTEE AGAINST ACCIDENTS THAT CAN OCCUR IN THE WORKPLACE.

SCRUBBERS ARE DESIGNED TO PROVIDE UTMOST SAFETY IF USED ACCORDING TO INSTRUCTIONS. THIS MACHINE IS INTENDED FOR COMMERCIAL USE, FOR EXAMPLE IN HOTELS, IN SCHOOLS, IN HOSPITALS, IN FACTORIES, IN SHOPS, IN OFFICES AND IN BUSINESSES.

THIS MACHINE IS NOT INTENDED FOR USE BY PEOPLE (INCLUDING CHILDREN) WITH REDUCED PHYSICAL, SENSORY OR PSYCHOLOGICAL CAPACITY, OR WITH LACK OF EXPERIENCE AND KNOW-HOW. CHILDREN SHOULD BE MONITORED TO ENSURE THEY DO NOT USE THE EQUIPMENT TO PLAY ON.

THE USER MANUAL IS AN INTEGRAL PART OF THE SCRUBBER AND MUST ACCOMPANY IT UP TO ITS DEMOLITION.

PURSUANT TO DIRECTIVE 2006/42 EC, AND DPR 459 ON 24/07/1996 AND SUBSEQUENT UPDATES, IT IS MADE KNOWN THAT: OPERATOR IS INTENDED AS THE PERSON OR PEOPLE RESPONSIBLE FOR INSTALLING, OPERATING, ADJUSTING, CARRYING OUT ROUTINE MAINTENANCE, CLEANING, REPAIRING AND TRANSPORTING THE MACHINE.

THIS COMPANY CANNOT BE HELD LIABLE FOR PROBLEMS, BREAKAGES, ACCIDENTS OR OTHER ISSUES DUE TO LACK OF KNOW-HOW OR NON-APPLICATION OF THE PROCEDURES CONTAINED IN THIS MANUAL, OR DUE TO IMPROPER USE OF THE MACHINE.

THIS COMPANY ALSO CANNOT BE HELD LIABLE FOR CHANGES, INSTALLATION OF PARTS AND/OR ACCESSORIES WITHOUT PRIOR AUTHORISATION.



### **EMERGENCY SITUATIONS**

**IN THE EVENT OF FIRE, ONLY USE POWDER EXTINGUISHERS  
IF OCCURS ANY ABNORMAL BEHAVIOR (UNCONTROLLED SPEED INCREASE,  
OVERHEATING, ...) TURN OFF THE MACHINE IMMEDIATELY**

# MACHINE IDENTIFICATION

The machine and manufacturer are identified through three plates on the left of the driver's seat.

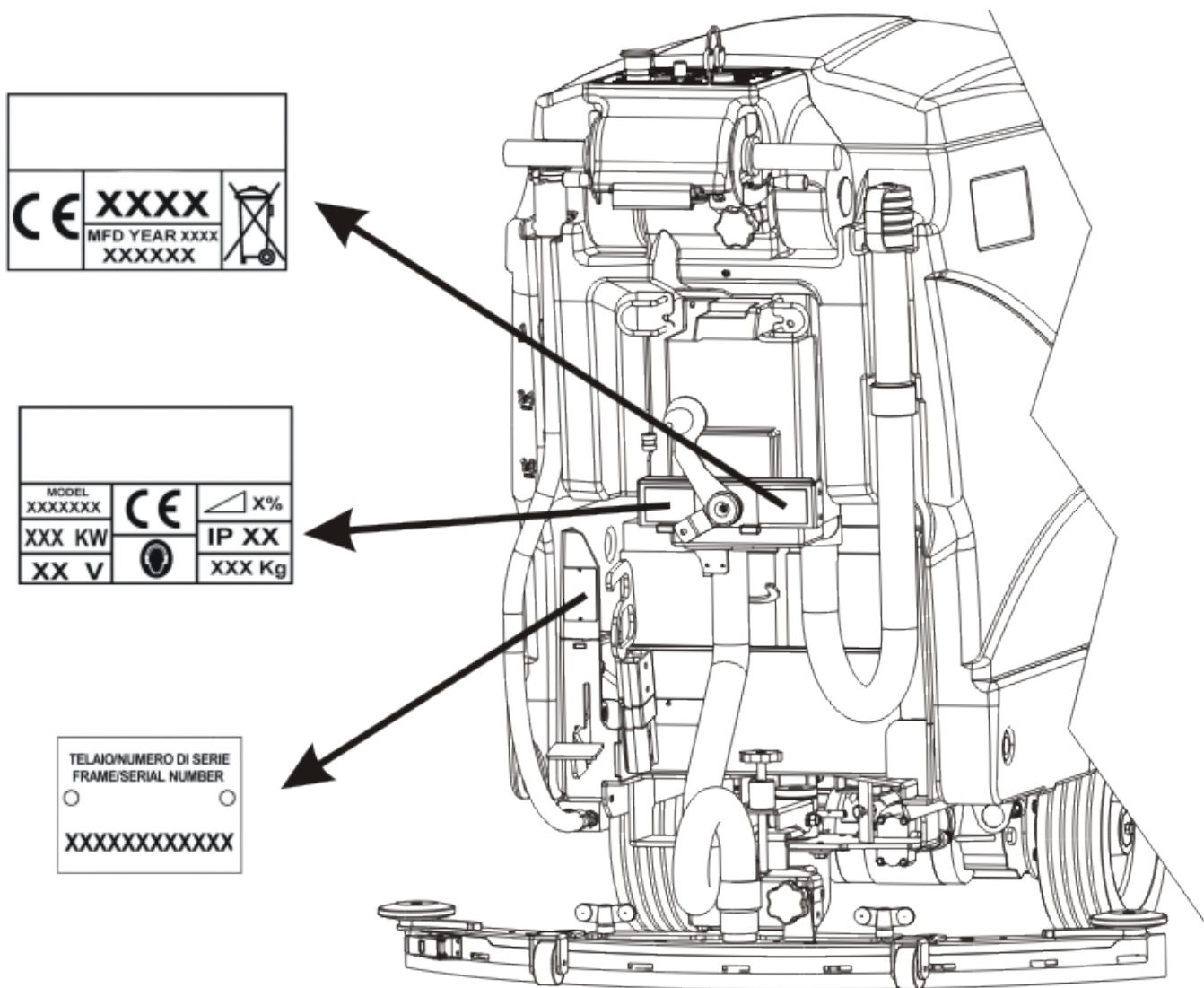

REFER TO THESE DETAILS TO ORDER SPARE PARTS OR WHEN SENDING ANY REQUEST TO THE MANUFACTURER.

The scrubbers comply with EEC directives and display the CE logo.

# GENERAL WARNINGS AND ADVICE

## DANGER - ATTENTION SIGNS



THIS SYMBOL HIGHLIGHTS ALL THE OPERATIONS THAT REPRESENT A SITUATION OF POTENTIAL DANGER FOR THE OPERATOR.  
THEREFORE, PROCEED IN COMPLIANCE WITH THE CONDITIONS HIGHLIGHTED BY THIS SYMBOL



USE OF GLOVES COMPULSORY



USE OF GOGGLES COMPULSORY



ATTENTION: MOVING PARTS, RISK OF TRAPPING HANDS



ATTENTION: DO NOT WET  
THE DEVICES MARKED WITH THIS INDICATION MUST NOT GET WET  
(THEY ARE NORMALLY ELECTRICAL COMPONENTS)



USE OF ANTI-VAPOUR MASKS WHEN USING CORROSIVE DETERGENTS



## RESPONSIBILITIES OF THE OPERATOR

- The operator is responsible for the day-to-day servicing of the machine.
- The operator must care for the machine and keep it in good operating condition.
- The operator must inform his or her superior or the technical department when scheduled maintenance is requested in the case of damage or breakage.
- The operator must not carry people, animals or objects on the machine.
- When moving the machine, observe the safety measures for circulation.
- The machine cannot be used for toxic-harmful materials.
- Never let people get close to the machine's sphere of action.
- Never leave the scrubber-dryer with the key inserted.
- If the machine malfunctions, have a look at the procedures shown in the various chapters.
- Never collect pieces of string, wire or anything else that could damage the brushes by winding around them.
- Never suck up pieces of wood, plastic waste etc. as they may clog the vacuum pipe.
- Never remove or alter the plates on the machine.

## IMPORTANT COMMUNICATION

WARNING! DURING THE LAST FEW YEARS, A NEW AGGRESSIVE SOLVENT-BASED DETERGENT TYPE WAS MADE AND DISTRIBUTED IN THE MARKET. THIS DETERGENT IS CURRENTLY NAMED AS "DETER-SOLVENT". EVEN IF THE SOLVENT CONTAINED IN THE DETERGENT IS OBTAINED FROM THE FRUITS, IT STILL HAS TO BE CONSIDERED AS "SOLVENT". THE POLIETHYLENE MATERIAL USED IN THE SCRUBBER TANKS IS MIXED WITH A % OF RUBBER. THE "DETER-SOLVENT" PRODUCT, IF LEFT IN THE SCRUBBER'S TANKS FOR A LONG PERIOD OF TIME COULD ATTACK THE RUBBER'S MOLECULAS, CAUSING THE TANK TO SWELL AND CRACK. IF THE "DETER-SOLVENT" PRODUCT IS USED, IT'S MANDATORY TO RINSE THE TANKS PROPERLY WHEN THE MACHINE STOPS WORKING.



## CLEANING AND MAINTENANCE

Machine cleaning must be carried out by staff correctly trained for the purpose, who know the controls to bypass energy sources and are familiar with the characteristics of the machine to avoid dangerous situations.

Clean the coverings of the machine, the panels and the controls with a cloth soaked in water or detergent solution.

No solvents must be used such as petrol, alcohol, etc.

Have specialist staff clean the electrical components who should use non-corrosive products, suitable for electrical circuits.

Maintenance of the machine must be carried out by specialist staff with in-depth knowledge of the machine and its components.

Any maintenance and cleaning must be carried out with the machine off, with all the mechanisms stopped, the hot parts cooled and the battery disconnected.

When using compressed air guns for cleaning, protect eyes and ears.

## STORAGE OF THE MACHINE

If the machine is unused for long periods of time, it is essential to:

- Recharge the batteries before storing the machine as empty batteries may get damaged;
- Empty and wash the tanks as described in the relative section;
- Clean the clean water filter, empty the filter protection and drain the water completely from the system;
- Clean the machine inside and outside. Avoid washing the machine using direct water jet, pressurized water, or corrosive substances;
- Keep the brushes and the squeegee raised;
- Remove the key and remove the battery lead connections;
- Keep the machine in a protected place;
- Keep the machine within a temperature range of 5°C / 40 °C;
- Keep the machine within a humidity range of 30°C / 80 °C.



## SAFETY PRECAUTIONS FOR OPERATORS AND TECHNICIANS

- The machine must not be used by non-authorized personnel who have not been trained to use it properly or by people who are under the influence of substances that could alter their nervous reflexes (alcohol, psycho pharmaceuticals, drugs etc.)
- Do not use the machine in inflammable areas or where there is the danger of explosions;
- Do not collect material that is alight or anything else that could cause a fire;
- Do not remove protections or guards when the machine is in operation;
- Do not use the machine to clean objects;
- Do not start to perform maintenance operations with parts in movement;
- Protect eyes and ears when using compressed air or water guns for cleaning the machine;
- To raise the machine make use of devices that are adequate to bare the weight of the machine itself;
- Do not cause flames or sparks around the machine;
- Disconnect the battery cables before working on the electrical circuit;
- Avoid contact with battery acid;
- Move carefully over uneven or crumbling paving and on slopes;
- Slow down on slopes and slippery surfaces;
- Make sure the machine is not exposed to rain and bad weather conditions, whether in motion or still;
- Temperature of usage of the machine must be kept within + 5 °C / + 40 °C;
- Humidity should be kept within 30% / 80 %.

### UPDATING OF THE USER'S MANUAL

When large-scale modifications are made to the machine or new parts are installed, the updated documentation must be sent to the Dealer along with the purchased part or as an update of the manual.

### OBLIGATIONS OF THE EMPLOYER OR OWNER OF THE MACHINE

The employer or owner of the machine is responsible for giving the User's Manual to all the personnel who are going to have to use the machine.

The employer or owner of the machine also undertakes to update the manual with the documentation that the Manufacturer will send if modifications are made to the machine.

# DISPOSAL



All packaging is recyclable. The packaging should not be thrown away with domestic waste, but sent to the relevant collection centres.



## EXHAUSTED LEAD-ACID BATTERIES

Exhausted batteries are considered harmful toxic waste and therefore should be exclusively given to collection companies with specific authorisation (ascertain on hand-over).

## MATERIAL COLLECTED FROM THE MACHINE

The waste collected by the machine must be given to the relevant urban cleaning company since it is considered urban waste or similar. The machine cannot be used to collect toxic-harmful materials.

## SCRAPPING THE MACHINE

On scrapping, proceed with the correct disposal of the materials that make up the machine. It is compulsory to give the machine to authorised collection companies which will correctly dispose of oil, filters, plastic, metal, electric motors, electric boards, etc. in compliance with legislation in force. Decommissioned equipment contains precious recyclable materials and therefore should be given to the relevant collection centres. Please dispose of decommissioned equipment through differentiated collection systems.

## DISPOSAL OF THE RECOVERY TANK SOLUTION

Prior to be moved to specific purification plants, the recovery tank solution is to be disposed of in appropriate sites.



## DISPOSAL OF ELECTRICAL EQUIPMENT AND ELECTRONICS



## TRANSPORT

The machine must be fixed to a pallet to make it easier to transport and more secure.

At the reception of the machine, check that the packaging is in good condition –in case of damage, inform the forwarder.

**PAY ATTENTION WHILE TRANSPORTING THE MACHINE AT TEMPERATURES BELOW 0°C TO PREVENT THE WATER INSIDE THE TANKS AND THE PIPES FROM BECOMING FROZEN.**

**DRAIN THE TANKS, REMOVE THE SCREEN OF THE CLEAN SOLUTION FILTER AND LET THE WATER FLOW AWAY COMPLETELY OUT OF THE PIPES.**



## TRANSPORT- HANDLING

When the machine is moved from one place to another you are advised to:

- Not load it on the vehicle with a forklift truck in order not to damage it;
- Lock the machine in place with the parking brake;
- Fix it well to the vehicle using belts, ropes and chains;



## TRANSPORTING THE MACHINE BY MANUAL PUSHING

In case of transport by means of manual pushing, for machines featuring electronic traction only, the machine must be pushed on at walking pace. Do not tow it with fork lifts



## UNPACKING

Make sure that all the parts indicated in the following list are present before unpacking the machine:

- Squeegee;
- Battery box;
- N° 1 battery jumper L = 26 cm, fitted with terminals and terminal covers;
- N° 2 battery jumpers L = 18 cm, fitted with terminals and terminal covers;
- Battery cable L = 48 cm, fitted with connector, terminals and terminal covers;
- Reducer for 6V battery box;
- On board battery charger;
- Four 6 Volt "dry-charged" batteries (optional).

NOTICE: brushes, discs and disc pad holders must be purchased separately.

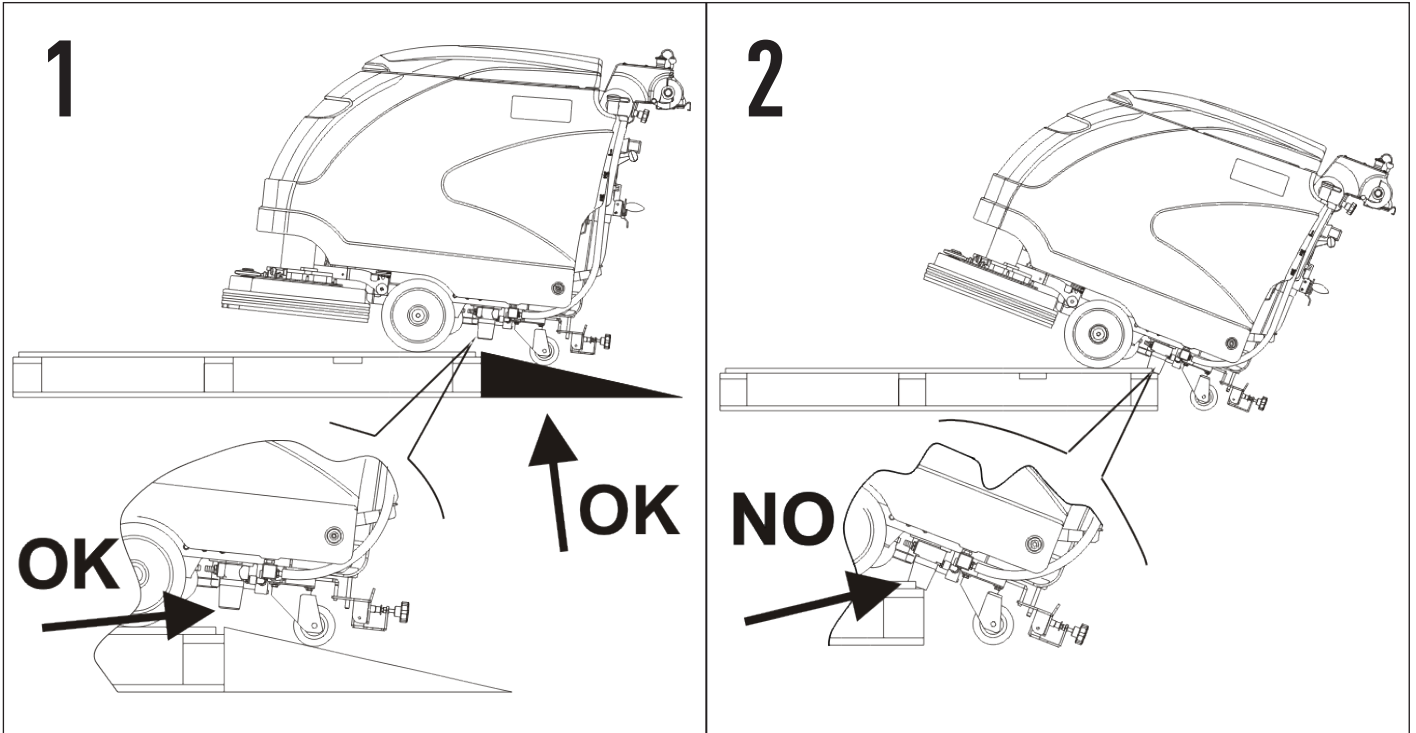

Follow the instructions below to unpack the machine:

- Connect the inclined ramp to the front part of the pallet, see figure 1;
- Remove the fasteners fixing the front wheels and eventual other devices;
- Make use of the inclined ramp (see fig. 1); do not try to unload the machine without the ramp as not to damage the clean water filter (see fig.2).

**CAUTION: DO NOT USE A FORKLIFT TO REMOVE THE MACHINE FROM THE PALLET AS IT MAY CAUSE DAMAGE TO THE MACHINE.**

**CAUTION: MOUNT THE BATTERIES ONLY AFTER REMOVING THE MACHINE FROM THE PALLET.**

# LIFTING THE TANK

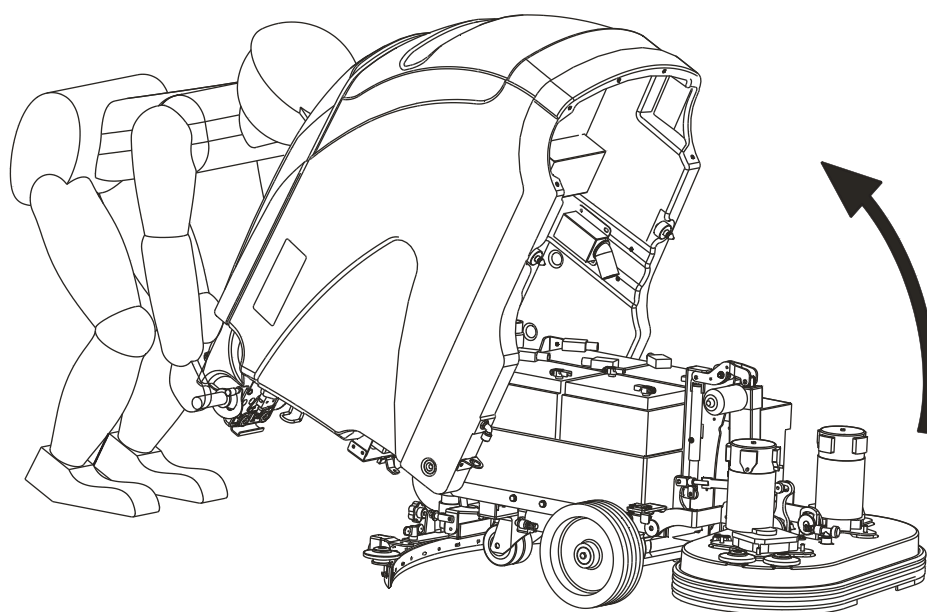
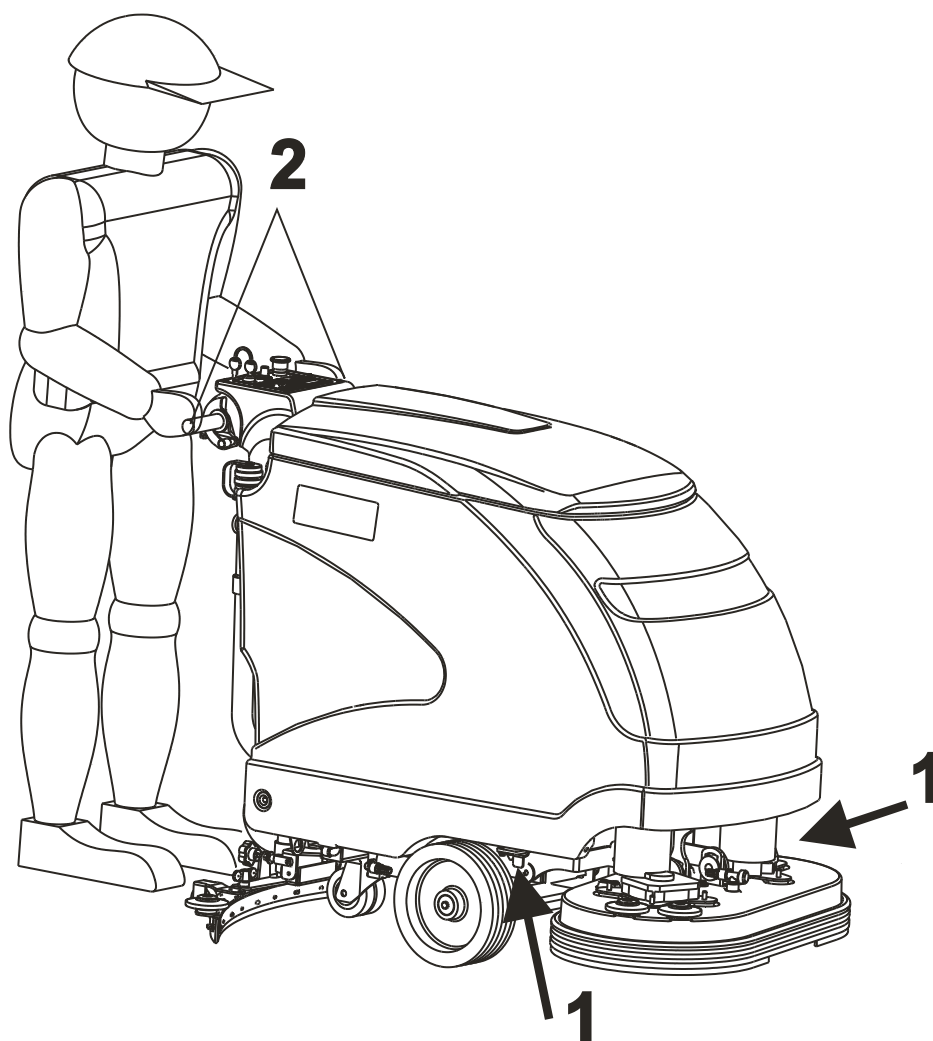

Follow the instructions below to lift the tank:

- Bring the machine into a stop position in a flat surface area, put on the brake and turn the key into pos.0;
- Unblock the tank by means of the two levers pos.1 placed on both sides;

**REACH THE DRIVER'S POSITION AND LIFT THE TANK BY THE GRIPS (POS.2) PAYING ATTENTION TO HANDLE IT WITH CARE WHILE PUTTING IT DOWN ON THE GROUND**



# INSTALLING BATTERIES

**CAUTION: USE PROTECTIVE GLOVES AND GOGGLES WHEN HANDLING BATTERIES, AVOIDING ANY CONTACT WITH THE ACID INSIDE THE BATTERIES.**

**CAUTION: THE BATTERY CHARGER AND THE CONTROL BOARD ARE SET ACCORDING TO THE TYPE OF BATTERIES SHOWN IN THE SHEET ATTACHED TO THE USER'S MANUAL.**

**IF YOU WANT TO MOUNT BATTERIES WITH A DIFFERENT AMPERAGE OR OF A DIFFERENT TYPE (I.E. LEAD-ACID, AGM OR GEL) THE SETTING SHOULD BE DONE ON THE BATTERY CHARGER AS WELL AS ON THE CONTROL BOARD ON THE MACHINE. CONTACT A RESELLER OR A TECHNICIAN BEFORE MOUNTING THESE TYPES OF BATTERIES.**

Refer to the specification sheet for battery types and sizes suitable for the machine.

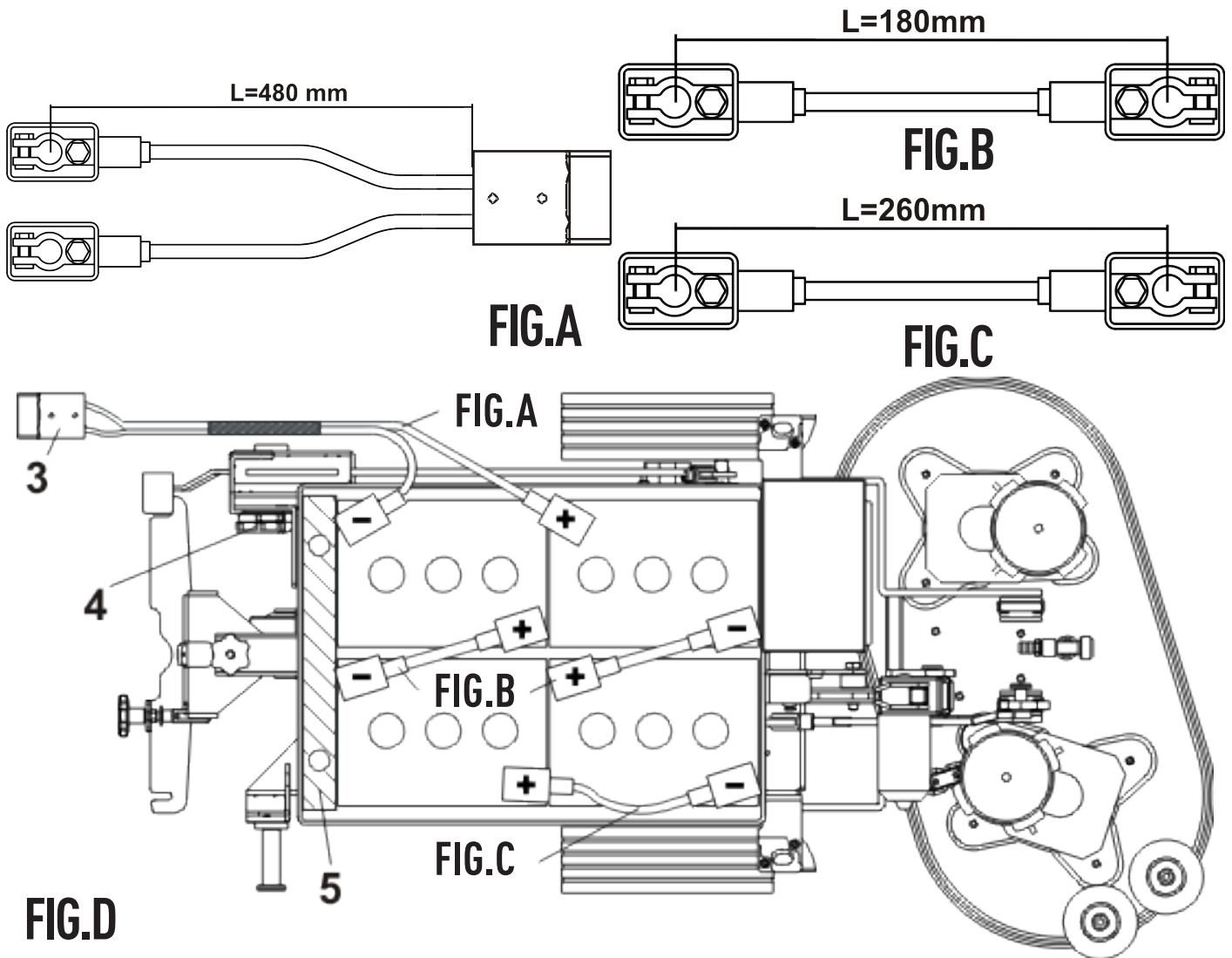

Follow the instructions below to mount the batteries to the machine:

- Park the machine on a flat surface, put on the brake (if available) and remove the key (if available);
- Lift the tank following the instructions as indicated in the previous section of the present manual;
- Place the batteries in the battery box. Make sure the poles are clean and apply a thin layer of petroleum jelly.

**BE VERY CAREFUL NOT TO TURN OVER THE BATTERIES AS IT COULD CAUSE ACID TO LEAK AND DAMAGE THE MACHINE.**

- Insert the battery box reducer pos.5 as shown in fig. D;
- Connect the two jumpers 1=180mm (fig. B), the jumper 1=260 mm (fig. C) and the battery cable (fig. A) as shown in fig. D; make sure to tighten the screws on the terminal clamps and place the terminal covers;
- Connect the mobile connector (pos.3 fig. D) with the fixed connector (pos.4 fig. D) into the machine.

# MACHINE DESCRIPTION

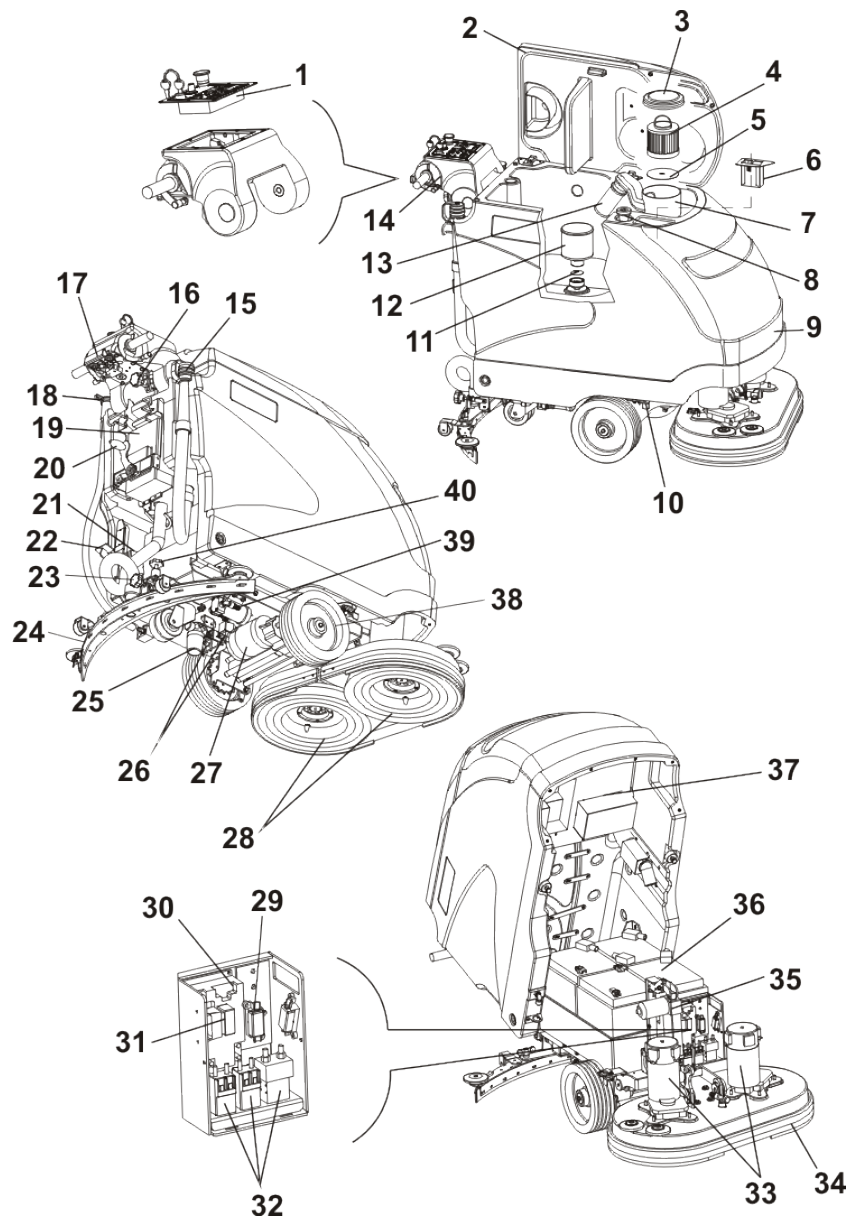

- |   |   |
|---|---|
| 1. CONTROL BOARD  | 21. BATTERY MOBILE CONNECTOR                |
| 2. TANK LID   | 22. BRAKE PEDAL                             |
| 3. SUCTION FILTER LID                                   | 23. SQUEEGEE ADJUSTMENT HAND-WHEEL          |
| 4. SUCTION FILTER                                       | 24. SQUEEGEE                                |
| 5. SAFETY SUCTION FILTER                                | 25. DETERGENT SOLUTION FILTER               |
| 6. CLEAN WATER TANK FILLING WATER                       | 26. SOLENOID VALVES                         |
| 7. FILTER SUPPORT                                       | 27. DRIVE GEAR MOTOR                        |
| 8. DRUM OF THE CLEAN WATER FILTER                       | 28. BRUSHES                                 |
| 9. TANK   | 29. FUSE HOLDER                             |
| 10. UNLOCK TANK LEVER                                   | 30. DRIVE BOARD                             |
| 11. ECO-SYSTEM SAFETY FILTER (ECO VERSION)              | 31. FUSE HOLDER                             |
| 12. ECO-SYSTEM FILTER (ECO VERSION)                     | 32. CONTACTORS                              |
| 13. SUCTION LOCK FLOAT WITH FILTER                      | 33. BRUSH GEAR MOTOR                        |
| 14. CONTROL PANEL                                       | 34. SPLASHGUARD                             |
| 15. RECOVERY TANK OUTLET DRAIN                          | 35. UP/DOWN BRUSH PLATE ACTUATOR            |
| 16. SQUEEGEE SLOPE ADJUSTMENT HAND-WHEEL                | 36. BATTERIES                               |
| 17. ANTI-CRUSHING DEVICE                                | 37. SUCTION MOTOR BOX                       |
| 18. LEVEL INDICATOR PIPE AND SOLUTION TANK OUTLET DRAIN | 38. WHEELS                                  |
| 19. BATTERY CHARGER                                     | 39. WATER PUMP                              |
| 20. SQUEEGEE LEVER                                      | 40. SQUEEGEE PRESSURE ADJUSTMENT HAND-WHEEL |

## CONTROL PANEL

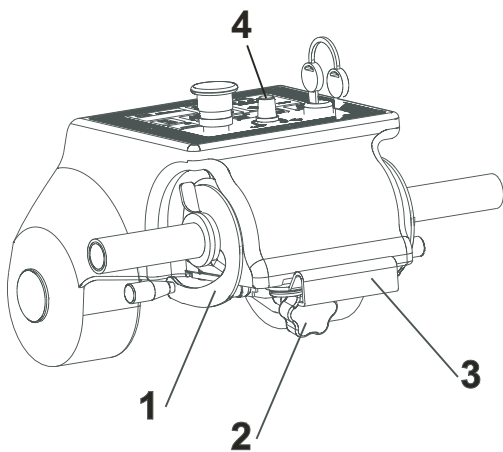

### 1 - DRIVE OR REVERSE DRIVE CONTROL

Rotate the mechanism forward to drive the machine. Rotate the mechanism backwards for reverse drive. The speed of the machine will either increase or decrease progressively when rotating the control progressively forward or backwards, it will go from speed level 0 (machine in halt position) to the maximum speed set with the potentiometer (pos.4) located on the instrument panel.

### 2 - INSTRUMENT PANEL INCLINATION ADJUSTMENT HAND-WHEEL

Enables the instrument panel to be positioned in three different inclinations.

### 3 - ANTI-CRUSHING DEVICE

This is a safety device that halts the machine in reserve drive and makes it go forward for a brief period in case the operator is trapped between the machine and an obstacle behind him.

## BRAKE PEDAL

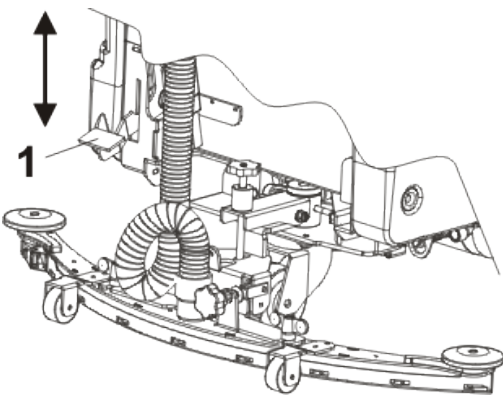

The machine is fitted with a parking and emergency brake that operates on both front wheels. To lock the machine, push the brake pedal (pos.1) down and hook it into the pre-set housing. The machine will then be locked. Use the brake pedal (pos.1) to unlock the machine, unhook it from the housing and release it slowly. The machine will then be unlocked.

## SETTING THE CHARGE INDICATOR

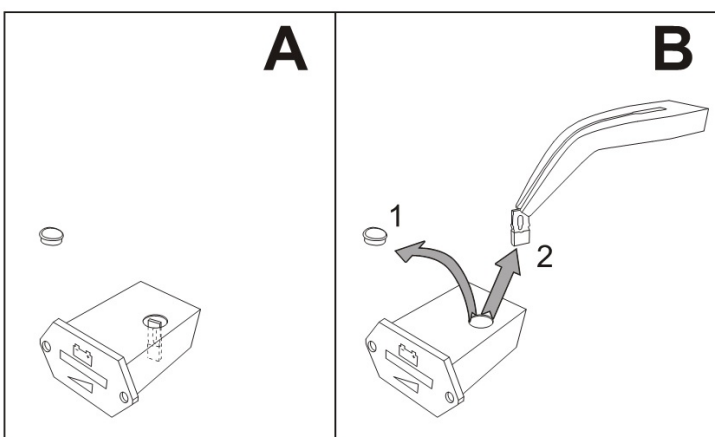

With the jumper inserted, the charge indicator is set for lead acid batteries (FIG.A). Without the jumper, the charge indicator is set for gel/agm batteries (FIG.B). If the indicator is set for gel/agm batteries and you want to install lead acid batteries, please contact the company for the jumper.

# MAIN FUNCTIONS AND CONTROLS

## E71 TRAC TRONIC - E81 TRAC TRONIC

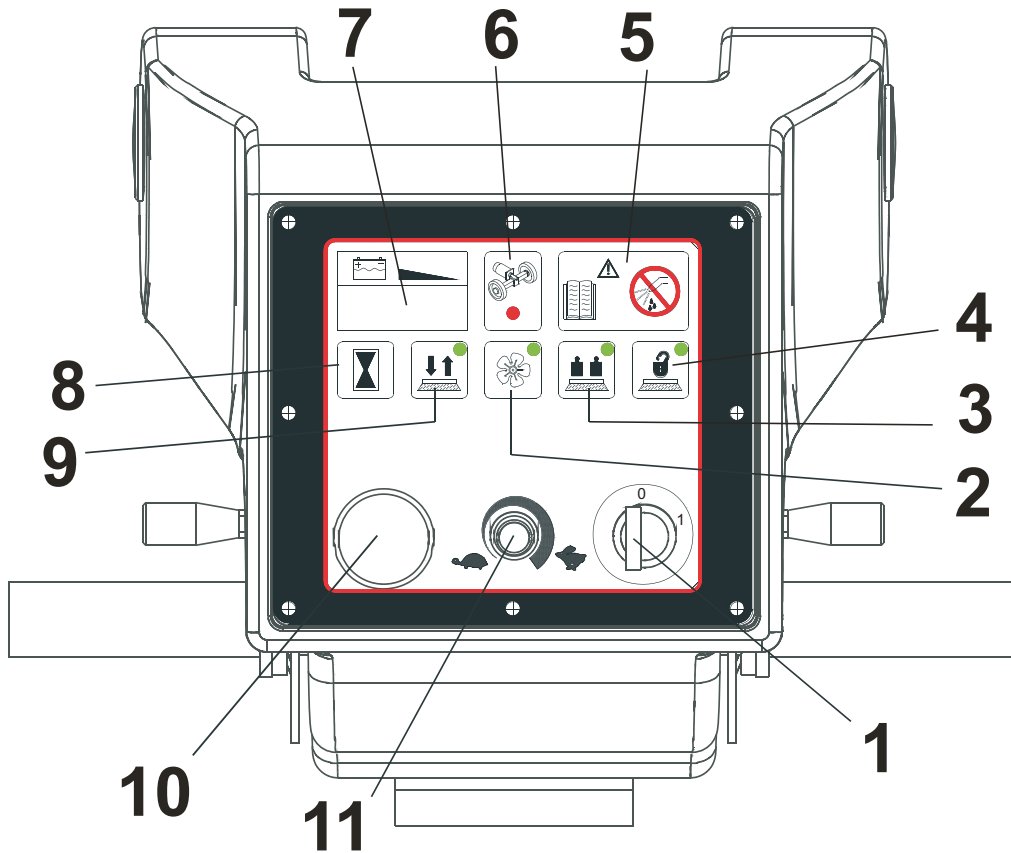

### KEY-OPERATED SWITCH

1



The ignition sequence will start by rotating the key-operated switch clockwise (position 1); a series of information will appear on the display in successive order. **THE BUTTONS ON THE INSTRUMENT PANEL AND THE DRIVE CONTROLS SHALL NEVER BE TOUCHED DURING THIS SEQUENCE.** The charge level of the battery will appear on the display at the end of the sequence, e.g. 100 - 90 - 80 etc.  
The machine is ready to be used only at this point.

2



### SUCTION FAN BUTTON

If the suction fan is switched off, this button can be used to turn it on and a green light indicator will come on. If the suction fan is switched on, this button can be used to turn it off after a pre-set delay.

3



### EXTRA-PRESSURE BUTTON

Press this button to increase pressure on the brush plate; a green led light will come on. This function can be activated only if the brush function is already active. Switch it off to disable extra-pressure and work in normal conditions. By pressing the brush button when working on extra-pressure mode, you will cause the brushes to stop rotating and the brush plate to automatically rise.

4



### BRUSH RELEASE BUTTON

This button will enable the brush release sequence. The led light will start blinking during this sequence. This operation shall be carried out with the machine in halt position and with the brush plate in raised position.

5



### WARNING SYMBOLS

The symbol on the left advises using the instruction manual at all times for any information regarding the machine, whereas the symbol on the right forbids washing the instrument panel with heavy water jets as there are electrical parts.

6

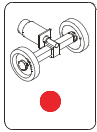

### RED WARNING LIGHT: DRIVE ALARM

It shows any anomalies present on the motor's drive board.  
The number of blinks indicates the type of fault (see troubleshooting table).

7

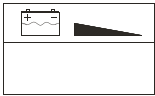

### CHARGE BATTERY LEVEL INDICATOR AND DISPLAY

The charge level of the battery is displayed when the machine is switched on (100 – 90 – etc). When the battery charge level reaches 20, the number on the display starts blinking and the brush operation is disabled since a protection device is triggered to prevent the battery from getting damaged, however the suction and drive functions remain active.

At this point, the brush plate shall be raised and the floor shall be dried quickly.

Upon reaching level 10, the number on the display shall start blinking and the suction function will also be disabled, the drive function will be the only active function. Lift the squeegee, go to the tank drainage area and charge the batteries.

When 4 blinking dashes (----) appear on the display, the drive will also be disabled as the battery reaches a minimum discharging threshold. Therefore, the machine must be pushed over to the tank drainage area and then pushed over to the battery charging area.

8



### HOUR METER BUTTON

Hold down this button to display the operating hours of the machine.

9



### BRUSH BUTTON

Press this button to enable the brush function; a green led light will come on. The brushes will start rotating when the machine is set in motion. When the control is released, the brush will rotate for a further 3 seconds before stopping. In case of a prolonged halt, after 1 min the brush plate will automatically rise.

When the machine is in motion with lowered brushes, by pressing the brush button the brushes will stop rotating and the brush plate will automatically rise. With the extra-pressure function on, by pressing the brush button the brushes will stop rotating and the brush plate will automatically rise. The solenoid valve is also connected to the brush function and allows the user to automatically open or shut the flow of the solution while the brush is rotating.

10

### EMERGENCY BUTTON

This button is used to halt the machine in case of emergency and to lock all its functions.  
Turn the knob clockwise to reset the power.

11



### SPEED ADJUSTING POTENTIOMETER

To set up the maximum speed of the machine turn the knob clockwise or counter-clockwise.

# MAIN FUNCTIONS AND CONTROLS

E71 ECO - E81 ECO

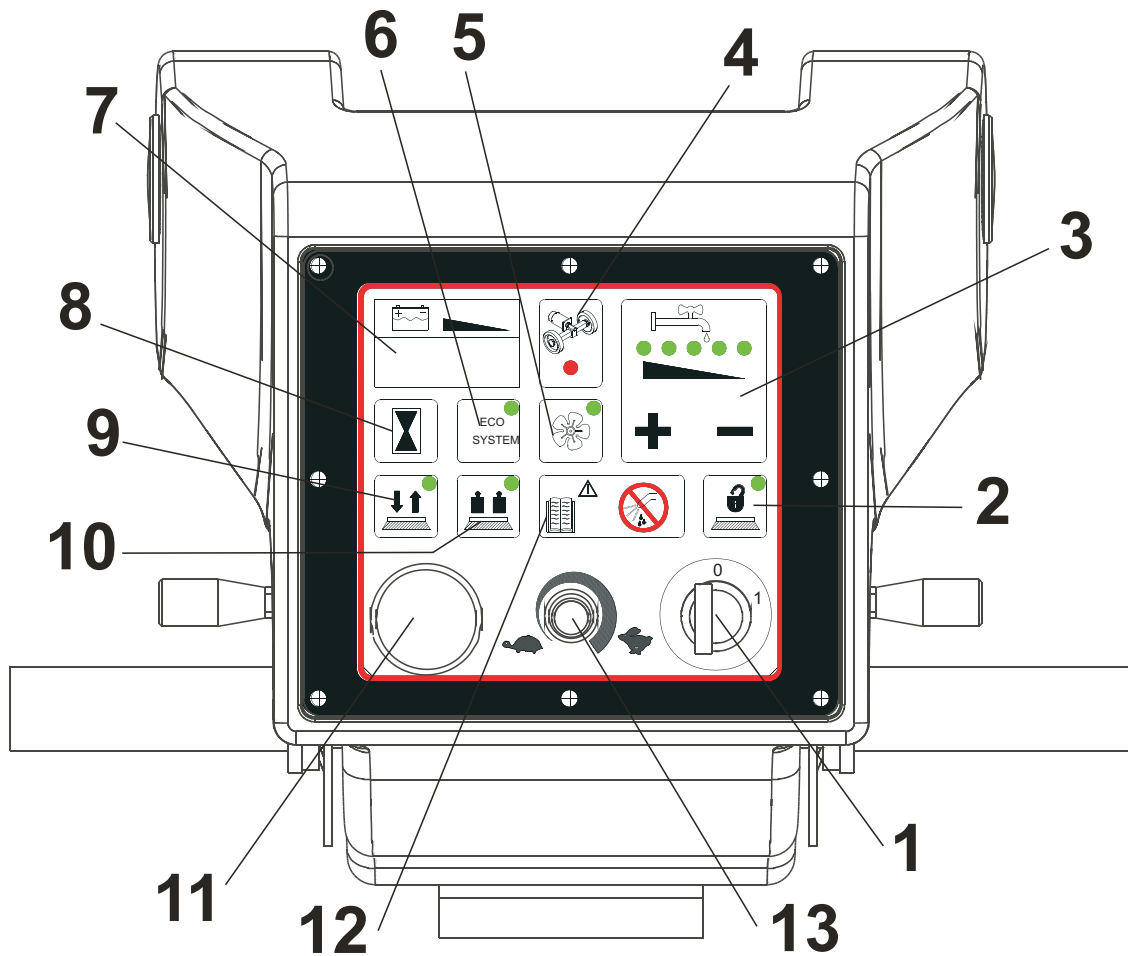

## KEY-OPERATED SWITCH

1



The ignition sequence will start by rotating the key-operated switch clockwise (position 1); a series of information will appear on the display in successive order. **THE BUTTONS ON THE INSTRUMENT PANEL AND THE DRIVE CONTROLS SHALL NEVER BE TOUCHED DURING THIS SEQUENCE.** The charge level of the battery will appear on the display at the end of the sequence, e.g. 100 - 90 - 80 etc. The machine is ready to be used only at this point.

2



## BRUSH RELEASE BUTTON

This button will enable the brush release sequence. The led will start blinking during this sequence. This operation shall be carried out with the machine in halt position and with the brush plate in raised position.

3

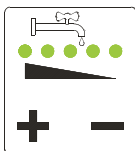

## WATER ADJUSTMENT BUTTONS

Use the buttons + or - to set the maximum quantity of water to use for the operation. Press the + button to increase the quantity of water; the 5 green led lights on the panel come on progressively one at a time. Each led light is associated with a maximum pre-set quantity of water. Press the - button to decrease the quantity of water; the 5 led lights will go out progressively one at a time. The water is shut off when all the leds are off. The machine keeps memory of the adjusted quantity of water even when switched off.

4

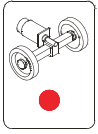

#### RED WARNING LIGHT: DRIVE ALARM

It shows any anomalies present on the motor's drive board.  
The number of blinks indicates the type of fault (see troubleshooting table).

5



#### SUCTION FAN BUTTON

If the suction fan is switched off, this button can be used to turn it on and a green light indicator will come on.  
If the suction fan is switched on, this button can be used to turn it off after a pre-set delay.

6



#### ECO-SYSTEM OPERATION BUTTON

Press this button to enable the ECO-SYSTEM.  
The green light is on when the system is operating.

7

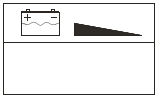

#### CHARGE BATTERY LEVEL INDICATOR AND DISPLAY

The charge level of the battery is displayed when the machine is switched on (100 – 90 – etc). When the battery charge level reaches 20, the number on the display starts blinking and the brush operation is disabled since a protection device is triggered to prevent the battery from getting damaged, however the suction and drive functions remain active.

At this point, the brush plate shall be raised and the floor shall be dried quickly.

Upon reaching level 10, the number on the display shall blink and the suction function will also be disabled; the machine drive function will be the only active function. Lift the squeegee, go to the tank drainage area and charge the batteries.

When 4 blinking dashes (----) appear on the display, the machine drive will be also disabled as the battery reaches a minimum discharging threshold. Therefore, the machine must be pushed over to the tank drainage area and then pushed over to the battery charging area.

8



#### HOUR METER BUTTON

Hold down this button to display the operating hours of the machine.

9



#### BRUSH BUTTON

Press this button to enable the brush function; a green led light will come on.

The brush will start rotating when the machine is set in motion.

When the control is released, the brush will rotate for other 3 seconds before stopping. The solenoid valve is also connected to the brush function and allows the user to automatically open or shut the flow of the solution when the brush is rotating.

10



#### EXTRA-PRESSURE BUTTON

Press this button to increase pressure on the brush plate; a green led light will come on. This function can be activated only if the brush function is already active. Switch it off to disable extra-pressure and work in normal conditions. By pressing the brush button when working on extra-pressure mode, you will cause the brushes to stop rotating and the brush plate to automatically rise.

11

#### EMERGENCY BUTTON

This button is used to halt the machine in case of emergency and to lock all its functions.

Turn the knob clockwise to reset the power.

12



#### SPEED ADJUSTING POTENTIOMETER

To set up the maximum speed of the machine turn the knob clockwise or counter-clockwise.

13



#### WARNING SYMBOLS

The symbol on the left advises using the instruction manual at all times for any information regarding the machine, whereas the symbol on the right forbids the use of water on the instrument panel as there are electrical parts.

# SETTING UP THE MACHINE



## MOUNTING THE SQUEEGEE

Follow the instructions below to mount the squeegee to the machine:

- Park the machine on a flat surface, put on the brake (if available) and remove the key (if available);
- Position the squeegee lever into position 1 (raised position).
- Fit in the squeegee (pos.A) into the squeegee support (pos.C).
- Once the squeegee is fitted completely, secure the knobs (pos.B).

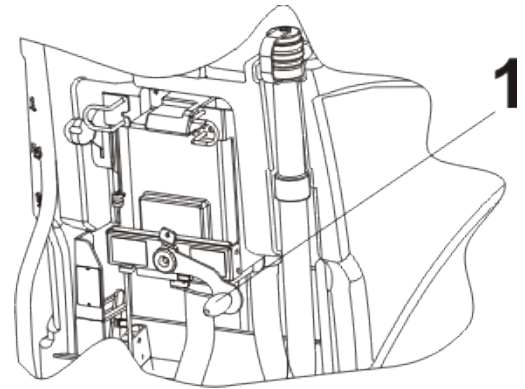
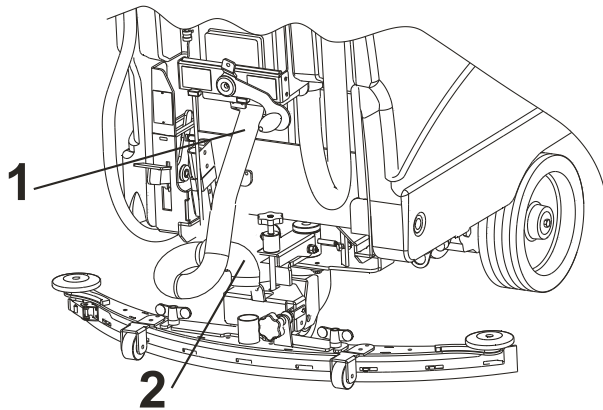
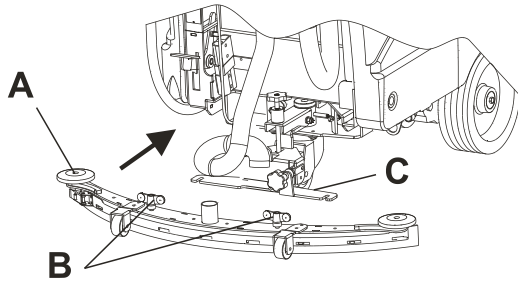

- Connect the squeegee hose from the straight side (pos.1) into the special seat located on the bottom of the tank and press down hard until it fits into place completely.
- Mount the other end of the hose, from the roll-up side (pos.2) into the squeegee. The hose's curve will be used as an anti-drip device.

## ADJUSTING THE SQUEEGEE

There are 2 types of adjustments that can be carried out on the squeegee:

- **Inclination adjustment** with knob (pos.1).

It adjusts the inclination of the squeegee in order to have a constant pressure over the entire length of the blade (pos.2). Turn the knob counter-clockwise if there is too much pressure on the outer points and little pressure on the central area. Turn the knob clockwise if there is little pressure on the outer points and too much pressure on the central area. To make the adjustment lower the squeegee, turn on the suction fan and drive forward slowly. Examine the pressure distribution on the blade and if necessary correct the inclination as described above.

- **Pressure adjustment** using the knob in position 3.

This allows for optimal pressure on the blade (position 2) which can be adjusted for each type of floor and for each type of blade. For rough floors or uneven floors, increase the pressure by turning the knob (pos.3) clockwise. For smooth floors, lower the pressure by turning the knob counter-clockwise.

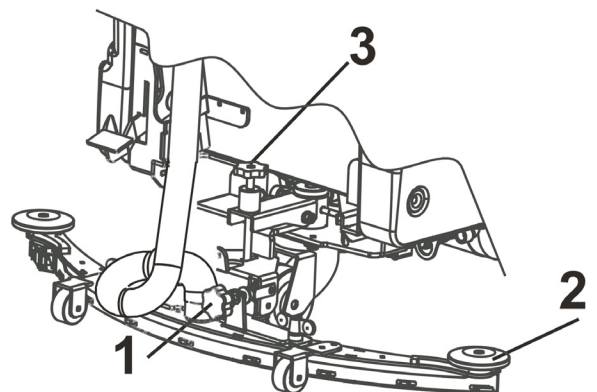



## ADJUSTING THE SQUEEGEE OSCILLATING

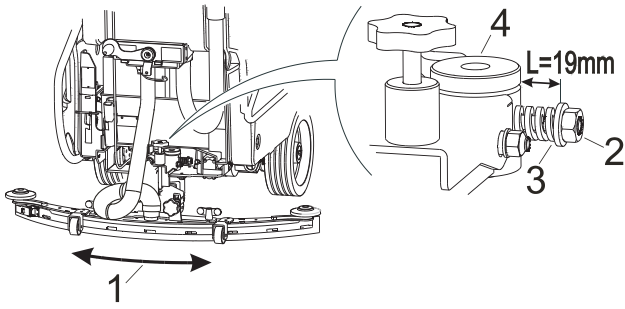

The smoothness of the squeegee oscillating movement can be adjusted; this movement is indicated by the arrow (pos.1).

Use the screw (pos.2) to make the adjustment. The original settings establish a distance of 19 mm between the inner part of the washer (pos.3) and the hub (pos.4). If the screw (pos.2) is driven in, the 19mm distance is reduced and the squeegee movement is less smooth. If the screw is twisted off, the opposite effect is achieved.

However, make sure that the inclination of the squeegee is set correctly before turning the screw (pos.2); in particular, be sure not to apply excessive pressure on the external parts of the squeegee as this could make it oscillate.



## MOUNTING THE BRUSH OR ABRASIVE DISC ON MACHINE

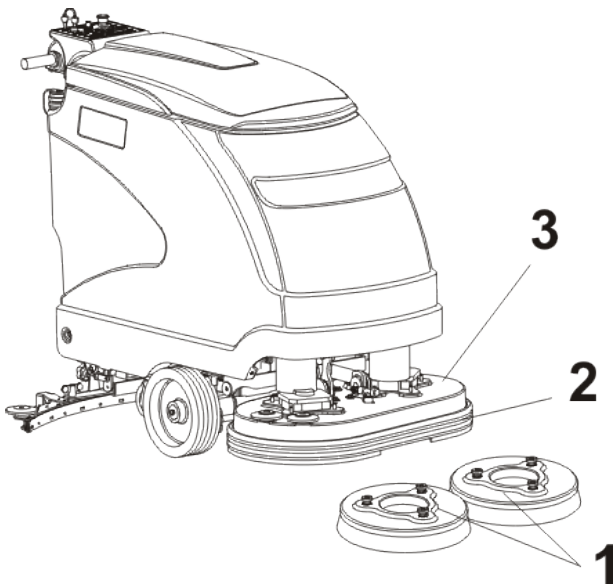

Follow the instructions below to mount the brush or disc pad holder with abrasive disc:

- Turn off the machine and press the key into position 0;
- Position the brush or disc pad holder (pos.1) under the brush plate lifting the splashguard (pos.2) if necessary;
- Turn the key into pos.1 and wait till the ignition sequence is over and the battery charge level is visible on the display;
- Lower the brush plate by pressing the brush button on the control panel (pos.3);
- Move the machine from right to left and vice versa until the brush fits into place correctly on the centre of the plate;
- Put the potentiometer for speed adjustment into min. position by pressing it towards the drawing of the turtle, on the label;
- Slowly push forward the drive control and release it as soon as the brush starts rotating. The brush motor will rotate for 2 seconds thus allowing for brush release. Repeat the same operation again if necessary.

Follow the instructions below to release the brush or disc pad holder with abrasive disc:

- Lift the brush plate and press the brush button to deactivate the brush function;
- Press the brush release button on the keyboard. The releasing sequence will be activated and the brush will be released from the plate.



## MOUNTING THE ABRASIVE DISC ONTO THE DISC PAD HOLDER

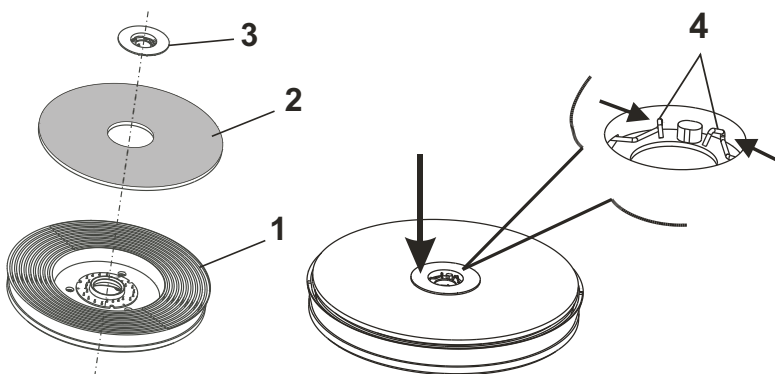

The machine can operate with brushes or abrasive discs of various types mounted on special disc pad holders. Follow the instructions below to mount the abrasive disc onto the disc pad holder:

- Remove the disc lock (pos.3) from the disc pad holder (pos.1) by pressing the 2 ends of the spring catch (pos.4) against each other;
- Position the abrasive disc (pos.2) and centre it onto the disc pad holder;
- Place the disc lock (position 3) on the centre and press down hard until the spring fits into place (position 4); this operation can be carried out using the palm of your hand, or your foot if the disc pad holder is resting on the ground.



## FILLING THE DETERGENT SOLUTION TANK

The tank should be filled using clean water mixed with an appropriate detergent solution suited for the type of floor and for the dirty conditions of the floor and using a product suitable for cutting down foam.

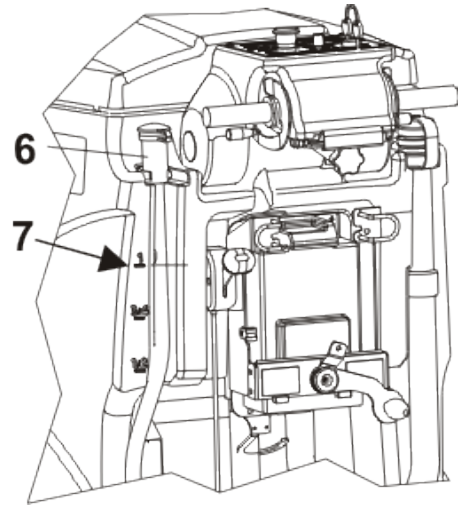
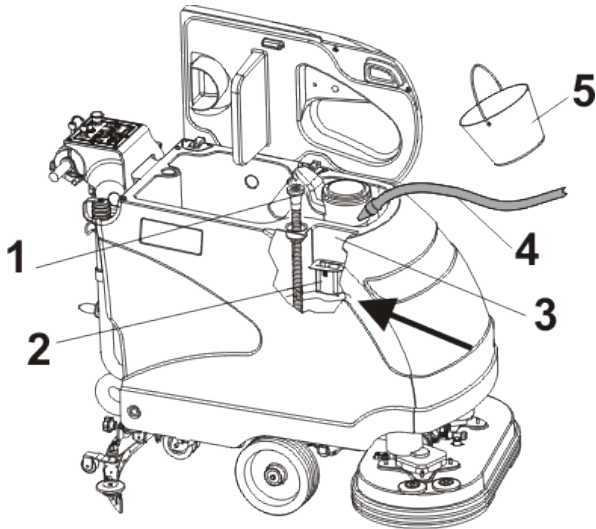

Use the mouth of the tank pos.3 to fill the solution tank.

There is a filter pos.2 located inside the mouth of the tank pos.3, which **should only be removed if the opening is clogged or obstructed**.

Use either a rubber hose pos.1 connected to the water distribution system or a clean bucket pos.3 and pour water into the tank.

Make sure the water used to fill the tank does not exceed 40°C. Look at the instructions on the package to determine how much detergent solution to use, how to mix the solution and what safety precautions to take before using the product.

**Make sure to use low-foaming liquid detergents or appropriate products to cut-down foam.**

Fill up the tank only to the level indicated by the filter (pos.2) without exceeding notch 1 (pos.7), which is in the rear part. The tank level can be viewed through the clear pipe (pos.6). For the machine to work properly, it is advisable not to exceed notch 1.

**WARNING: DO NOT POUR INFLAMMABLE LIQUIDS INTO THE TANK.**

## ADJUSTING THE QUANTITY OF SOLUTION ON THE BRUSHES (WATER + DETERGENT)

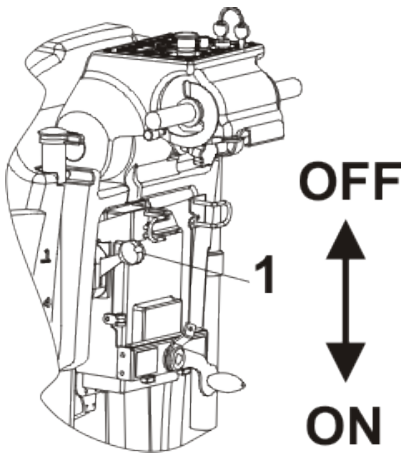

For the **TRAC TRONIC** version, the quantity of the solution on the brushes can be adjusted using the lever in position 1.

The lever in upward position will shut-off the flow of the solution completely. Push down the lever gradually so the valve can open and increase the flow of the solution progressively. Adjust the flow according to the operating speed and the dirty conditions of the floor.

The **TRAC TRONIC** version is fitted with a solenoid valve that keeps the solution from spilling out when the machine comes into a stop position.

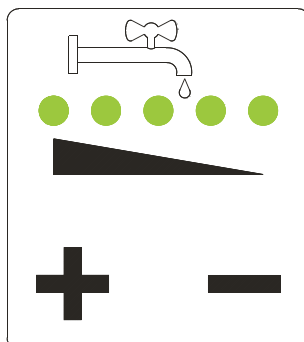
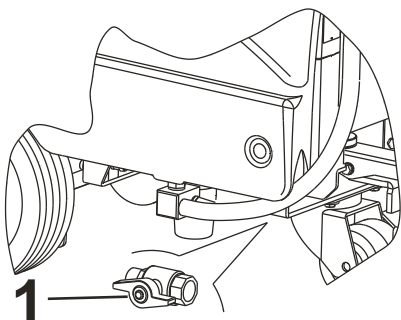

For the **ECO** versions, the quantity of the solution on the brushes can be adjusted using the + and - keys located on the instrument panel. Make sure the valve pos.1 located beneath the machine is open before operating the machine.

# USING THE MACHINE

Our scrubber-dryers must be operated by properly trained authorised staff.

Scrubber-dryers that do not operate properly must be taken out of service immediately.

## CHECK BEFORE USE

Make sure to check the following before using the machine:

- Make sure the battery connector is plugged-in;
- Make sure the key is fitted correctly;
- Check the battery charge level.

The charge level of the battery will appear in the instrument panel when the machine is on.

Charge the batteries if the battery charging level is low

- Make sure the brushes or discs are in good condition and mounted correctly;
- Make sure the splash guards that are mounted into the brush plate are in good condition;
- Make sure the rubber wheels on the squeegee are in good condition and set properly.

## OPERATION

- Release the parking brake and turn the key to position 1;
- Lower the squeegee by turning the special lever;
- Enable the brush function using the button in the instrument panel; the brushes will not start rotating until the drive command is enabled.

If during the washing operation the led of the brush bottom starts flashing, this means that there is an over-absorption of the motors. After 1 minute with the flashing led light, the writing E1 appears on the control board. The brushes will stop lifting the plate;

- When using the machine on particularly dirty surfaces, it is possible to have a further “extra-pressure” on the brush plate. This function can be activated by pressing the special button, and only if the brush function is already active. Switch it off to disable extra-pressure and resume normal working conditions.

By pressing the brush button when working on extra-pressure mode, you will cause the brushes to stop rotating and the brush plate to automatically rise.

If during the washing operation the led of the extra-pressure button starts flashing, this means that there is an over-absorption of the motors. After 1 minute with the flashing led light, the extra-pressure function will be deactivated automatically and you will continue working with the normal pressure;

- Turn on the suction fan using the special button in the instrument panel;
- Set the desired maximum operating speed using the potentiometer located in the instrument panel;
- For **TRAC** version, use the valve to adjust the quantity of the solution in the brushes;
- For the **ECO** version, set the maximum quantity of the desired solution using the + and – keys.

This version is fitted with an electronic solution dosing unit that operates in proportion to the speed of the machine and provides a constant and exact quantity of solution on the brush, preventing any waste. When the machine slows down, the flow of the solution automatically decreases and when the machine speeds up, the flow of the solution increases until reaching the maximum flow once the maximum speed is reached;

- To avoid damaging the floor, be very careful not to halt the machine over the same floor area while the brushes continue to operate;
- The brush will stop automatically after 3 seconds when the drive command is released and the solenoid valve will also shut off the flow of the solution. When resuming the drive operation, the brushes will restart and the solution will automatically start to flow. If the squeegee leaves wet lines on the floor during the washing operation, it means that there are pieces trapped beneath the rear rubber wheels of the squeegee. Lift the squeegee and remove the trapped pieces. Use a cloth to wipe off the rear rubber wheels if the pieces cannot be removed manually. In any case, it is always advisable to sweep the floors before washing;
- Make sure to check the level of the solution present in the clean water tank through the clear pipe. For **TRAC** version, once the detergent solution is used up, take the machine to the tank drainage area, drain the dirty water into the appropriate location, ready for disposal, then wash the water tank and fill up the tank with clean water and a mix of water and detergent solution, then resume the washing operation. On the **ECO** version, once the solution is used up, the machine can continue its washing operation using the ECO SYSTEM function that can be enabled by pressing the button located in the instrument panel, this will enable the machine to re-use the water from the recovery tank as the special tank filter duly filters it. The ECO SYSTEM device can be enabled at the operator's discretion whenever the clean water level drops to 1/4 of the tank. However, if the ECO SYSTEM is started when there is still some solution left in the clean water tank, the operation can be deactivated at any time and it is possible to resume washing using the solution from this tank. When using the ECO SYSTEM mode, the water is also distributed according to the speed of the machine, therefore the maximum quantity of water will flow when the machine reaches its maximum speed;

- It is advisable to run a pre-wash operation before washing very filthy floor surfaces;
- The machine is also fitted with a float valve that shuts off the suction function when the water level in the dirty water tank is too high.

Under standard machine operating conditions, when filling the clean water tank accordingly, the float valve will never be activated, unless the machine is handled roughly or the floor surface level is uneven. If the suction fan operation stops (which can be easily noticed as the noise of the suction motor will stop and the machine will no longer vacuum), open the lid and make sure the balls located in the float valve have dropped to release the suction function, then resume the operation;

- When completing the washing operation make sure to switch off the brushes using the special button, which will make the brush plate rise, even if working on extra-pressure mode, lift the squeegee, then turn on the suction function and take the machine to the tank drainage area.

The suction function is left in on-position to keep water from leaking out from the lid in case there are uneven areas on the floor while going to the tank drainage area.

# MAINTENANCE

SERVICING YOUR SCRUBBER-DRYER REGULARLY AND PERIODICALLY WILL ENSURE BETTER PERFORMANCE AND MORE DURABILITY. THE FOLLOWING PAGES CONTAIN INFORMATION THAT WILL HELP YOU PLAN THE MAINTENANCE AND CARE FOR THE MACHINE NEEDS.

**WARNING!:** DO NOT PERFORM ANY MAINTENANCE ON THE MACHINE OR ANY OF ITS COMPONENTS WITHOUT TURNING OFF THE MACHINE AND UNPLUGGING THE BATTERY CONNECTOR.

**WARNING!:** DO NOT TAMPER WITH ANY SAFETY DEVICE.

THESE DEVICES CAN ONLY BE REMOVED WHEN PERFORMING MAINTENANCE BY AN AUTHORISED ASSISTANCE CENTRE (AAC).



## DRAINING AND CLEANING THE RECOVERY TANK

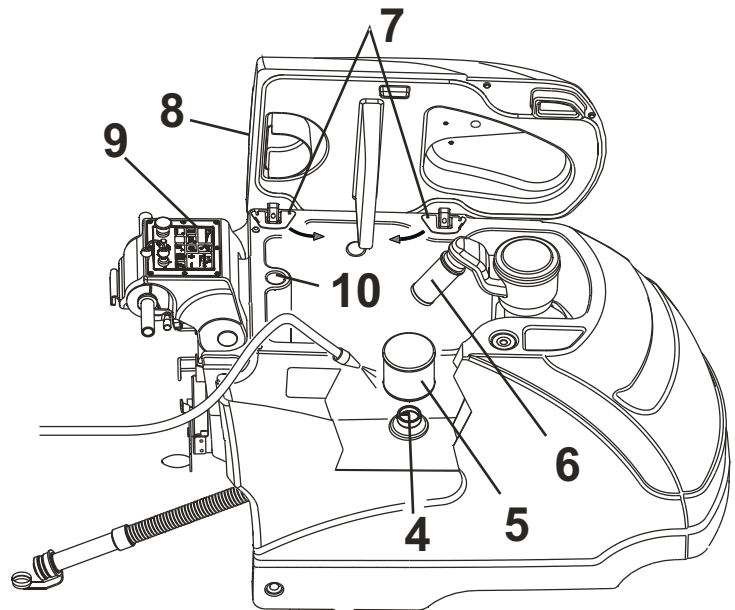
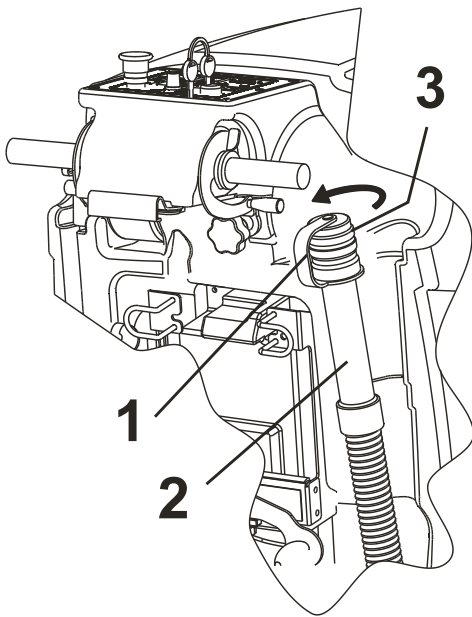

The recovery tank must be drained and cleaned after each washing operation.

To drain and wash the tank proceed as follows:

- Turn off the brush function and lift the brush plate;
- Lift the squeegee by pressing the special lever and go to the tank drainage area with the suction fan in on-position;
- Turn off the suction fan, turn the key to pos. 0 for the versions provided with a key and put on the brake.
- Remove the drain pipe from the dirty water tank pos.1 and while keeping the pipe vertically pos.2 open the lid by rotating it counterclockwise as indicated by the arrow. Part of the pipe is flexible pos.3 and therefore it can be squeezed to limit the water flow;
- After draining the tank, make sure to clean it thoroughly using water.

To ease this operation, use two fingers to rotate the 2 plates in the direction indicated by the arrows pos.7 and remove the cover pos.8;

- Wash the float valve pos.6 without removing it from the machine;
- For machines fitted with the ECO SYSTEM, use water to wash throughout the filter pos.5.

At the end of each working day, remove the filter from the tank and wash it carefully both inside and outside, as to remove any encrustation which might have got deposited in it. Before carrying out this operation, clean the tank thoroughly as well as the area around the filter. Screw the filter counterclockwise.

Do not remove the protective screen pos.4 located in the joint where the filter is positioned. To clean it, wash it using water;

- After completing the cleaning procedures, put the cap back on the dirty water drain pipe and rotate it clockwise, then place the pipe back into its housing in the tank;
- The suction duct on the squeegee as well as the suction pipe shall be washed periodically.

Before proceeding with the above operation, fit the water pipe into the duct pos.10 then let the water flow without removing the drain pipe. This will help prevent encrustation formation inside the duct, providing an optimal vacuum operation at all times.

**AVOID SPLASHING WATER ONTO THE BATTERY TRAY WHILE CLEANING THE TANK.**



## CLEANING INSTRUCTIONS ECO-SYSTEM

At the end of each working day take the machine to the tank draining area, turn off the key and activate the parking brake. Empty and wash the recovery tank. Start a cleaning cycle of the ECO-SYSTEM following the instructions shown in the label.

**ATTENTION!**

At the end of each use it is necessary to completely empty the Eco-System, even if this function has not been used.

**Instructions:**

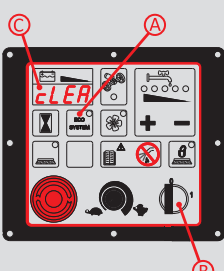

1. Take the machine to a drainage area and **switch it off**.
2. Simultaneously, **hold button (A)** (Eco - System) and **turn the key (B)** to position "1". **Hold until "cLEA" is displayed (C)**.
3. **After 5 seconds**, the drainage cycle will start, **lasting 40 seconds**.
4. Turn the key **(B)** to position "0" to **switch off the machine**.



Periodically, once a month, remove and wash carefully the ECO-SYSTEM filter. Start the automatic cleaning cycle (as indicated above). Pour water in the base of the ECO-SYSTEM to allow the complete washing of it (pipes, valve, pump). The cleaning operation will last about 40 seconds. If this time is not enough, repeat the complete cycle. To restore the normal functions of the machine, turn off and on the key. REASSEMBLE THE ECO-SYSTEM FILTER.



## DRAINING AND CLEANING THE SOLUTION TANK

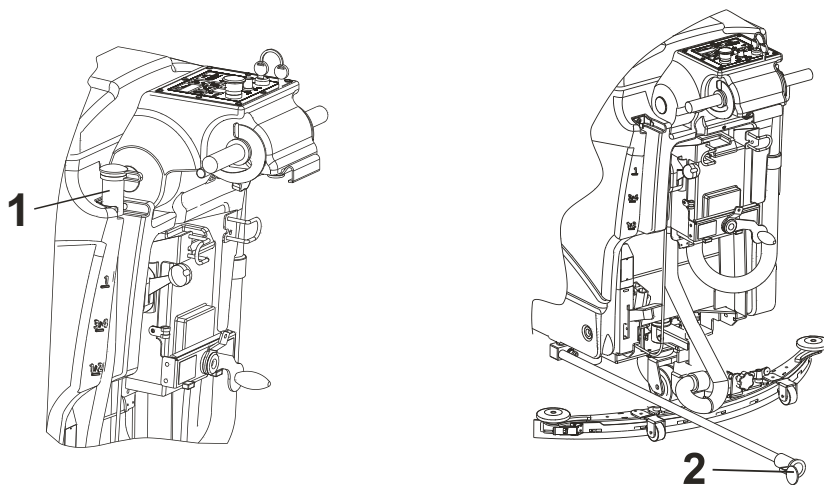

After completing the washing operation, to drain any leftover water from the solution tank, proceed as follows:

- Turn off the brush function and lift the brush plate;
- Lift the squeegee using the special lever, turn off the suction fan and go to the tank drainage area;
- Turn the key to position 0 for the versions provided with a key and put on the brake (if available);
- Unhook the transparent pipe indicating the clean water level pos. 1 from the knob on the control board;
- Remove the cap pos. 2 and lay the pipe on the ground;
- After completing the cleaning procedures, put the cap back on the dirty water drain pipe, then place the pipe back into its housing in the tank;
- The filter located in the mouth of the tank used for filling clean water should be cleaned periodically;
- It is also recommended to flush the tank periodically using water once it is drained completely; this will help prevent incrustations due to the detergent solution.



## CHECHING BRUSHES OR ABRASIVE DISCS

After using the machine, remove the brushes or discs by activating the brush release function.

- Check the condition of the brushes and replaced them if they are worn out (the length of the lower bristle shall not be less than 10 millimetres);
- Check the condition of the abrasive discs and replace them if worn out.

Make sure to switch the right brush with the left brush periodically to even out the wear so they can last longer



## CLEANING THE DETERGENT SOLUTION FILTER

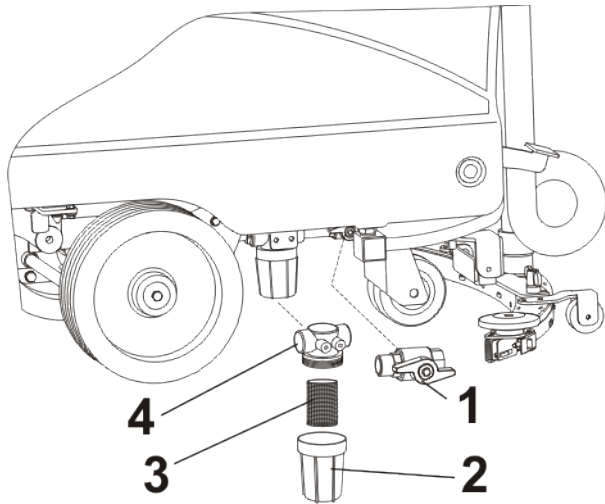

The machine is fitted with a filter on the duct that comes from the detergent solution tank. In theory, the solution located in this tank should not have any impurities as the buckets or containers used to fill the solution are supposed to be clean, in addition there is a filter in the mouth of the tank that filters the water. Follow the instructions below to clean the filter:

- Stop the machine and put on the brake. Turn off the machine and remove the key;
- Close the valve. For **TRAC TRONIC** version, use the lever handle nearby the instrument panel. For the **ECO** version, shut off the valve using the valve lever pos.1 as indicated in the drawing;
- Unscrew the clear cup manually pos.2;
- Remove the protective screen pos.3 and clean it with water together with the cup;
- Put the cup pos.2 and the protective screen pos.3 on the fixed part of the filter pos.4; make sure the protective screen is fitted correctly into its housing inside the cup and into the support;
- For **TRAC TRONIC** version, open the valve pos.1 or the lever handle located near the instrument panel.



## CLEANING THE SQUEEGEE

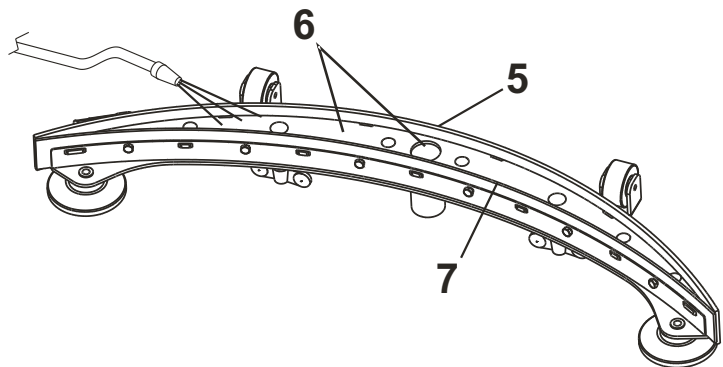
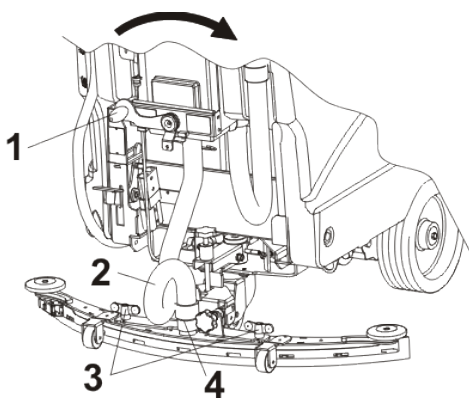

After completing the washing operation, clean the squeegee and make sure the blades are in good condition, then proceed as follows:

- Bring the machine into a stop position in a flat surface area, put on the brake (if available) and turn the key to position 0;
- Lift the squeegee using the lever pos.1;
- Unscrew both screw knobs pos.3 and remove the squeegee vacuum pipe pos.2 from the sleeve pos.4;
- Remove the squeegee, lay it on the ground facing up (as shown in the figure), wash it using water and for better vacuum flow, remove any pieces or incrustations from the lower part and from the mouth of the squeegee pos.6;
- Use a piece of cloth to wipe off the rear drying blade pos.5 and the front drying blade pos.4;
- Make sure the blades are in good condition and rotate them if necessary to have a new edge in contact with the floor.



## CLEANING THE PUMP OUTPUT PIPE FITTING (ECO)

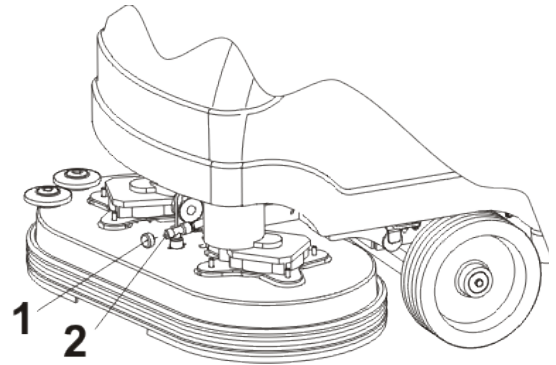

In the **ECO** versions, the machine is fitted with a metering pump for detergent solutions. If the solution does not flow out of the tank properly, make sure the output pipe fitting is not obstructed or clogged. To check that proceed as follows:

- Bring the machine into a stop position and put on the brake;
- Turn off the machine and remove the key;
- Unscrew the cap manually pos.1;
- Use a thin piece of wire of approximately  $\varnothing 3$  mm and remove any incrustations from the pipe fitting pos.2;
- Screw the cap back into place pos.1;



## REPLACING SQUEEGEE BLADES

The squeegee is fitted with two drying blades, a rear and a front blade, as specified in the previous paragraph. Each blade has 4 edges that can be used and rotated 4 times before being replaced, unless one of the edges is torn. For better drying performance, make sure the edge of the rear blade is not worn out. If the blade is worn out, rotate it or replace it.

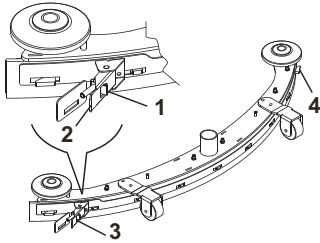

### REAR BLADE

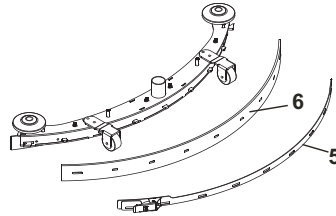

Follow the instructions below to rotate or replace the rear blade:

- Remove the squeegee from the machine;
- Remove the blade locking plate pos.5 by unlocking the retainer pos.3. This retainer is fitted with a safety device that keeps it from opening involuntarily. To release the retainer push the small lever pos.1 towards the outer part of the squeegee and then pull the big lever pos.2 towards the rear part of the squeegee;
- Follow the same procedure to remove the locking plate pos.5 from the other end of the squeegee pos.4;
- Remove the blade pos.6;
- Rotate the blade and mount it back so that a new edge is on the drying side;
- Hook the locking plate pos.4;
- Hook the retainer pos.3 and lock it into place.

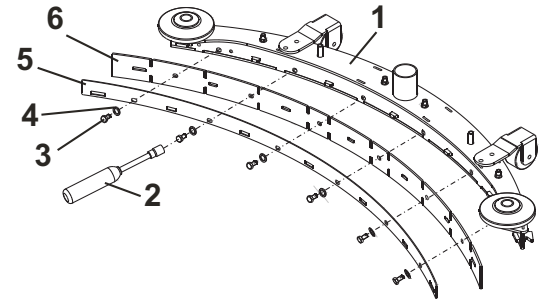

### FRONT BLADE

Follow the instructions below to replace the front blade:

- Remove the squeegee pos.1 from the machine;
- Use a 10-mm tubular nut driver pos.2 and remove the 6 screws pos.3 and the respective washers pos.4;
- Remove the blade locking plate pos.5;
- Remove the blade pos.6;
- Rotate the blade and mount it back so that a new edge is on the drying side of the blade;
- Put the blade locking plate pos.5 back into place;
- Put the 6 screws back into place pos.3, including the respective washers pos.4 and make sure not to tighten the screws excessively causing the rubber blade to deform (swell).

## CHECKING THE INSTALLATION OF THE SQUEEGEE BLADES

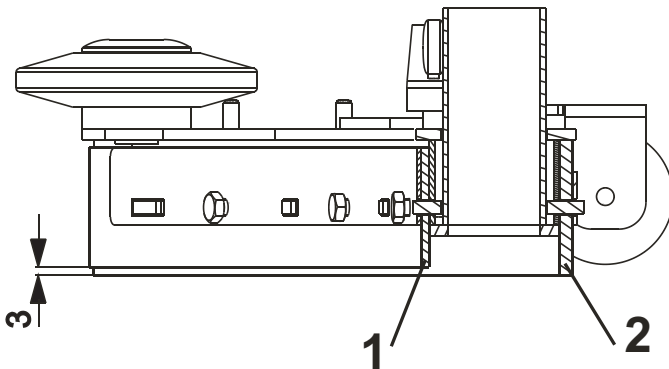

Once the squeegee blades are rotated or replaced, lay the squeegee onto a flat surface and check the following:

- Make sure the rear blade pos.2 is fitted correctly and levelled throughout its entire length. If the blade is not fitted evenly, release the blade locking plate and re-position the blade so that it is levelled correctly against the floor.
  - Make sure the front blade pos.1 is fitted evenly and check for any deformations due to tightening the screws excessively.
- Also make sure the blade is raised 3 mm above the ground throughout its entire length.



## CLEANING THE SUCTION FILTER

The machines are fitted with a washable cartridge filter on the suction duct, which provides two functions:

- 1) To filter the air vacuumed by the squeegee, trapping dust before releasing it into the environment, without putting it back into the air;
- 2) To protect the suction motor against dust that may ruin moving mechanical parts, making them last longer.

Follow the instructions below to clean the filter:

- Stop the machine in a flat surface area and put on the brake (if available);
- Drain the dirty water tank and wash it
- Turn off the machine and remove the key (if available);
- Open the cover pos.1;
- Remove the lid from the filter support pos.2;
- Position the ring pos.3 located above the filter into a vertical position and pull it vigorously until releasing the filter from its housing pos.4;
- Wash the filter with water and dry it using hot air, be careful not to damage it;
- There is a safety filter pos.5 located beneath the suction filter, which normally does not need any maintenance. However, if deemed necessary clean the filter without removing it from its housing;
- Put the air filter pos.4 back into place by pressing it down until it is fitted into its housing;
- Position the ring pos.3 back into horizontal position;
- Put the lid back on pos.2;
- Close the tank cover pos.1;

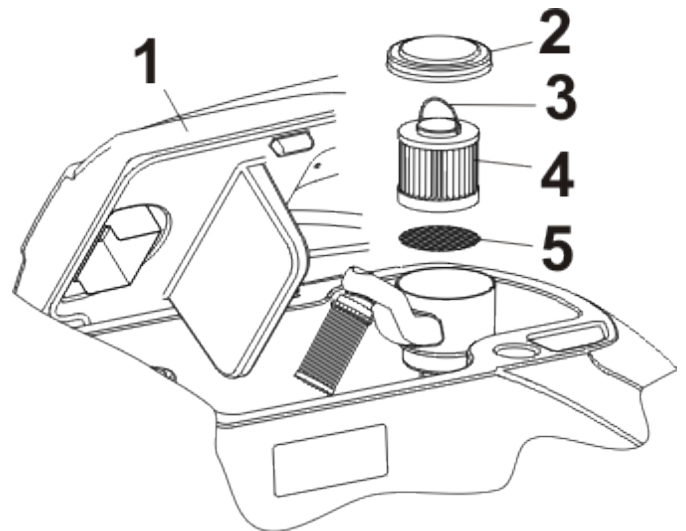

## CHECKING THE BRUSH PLATE SPLASHGUARD

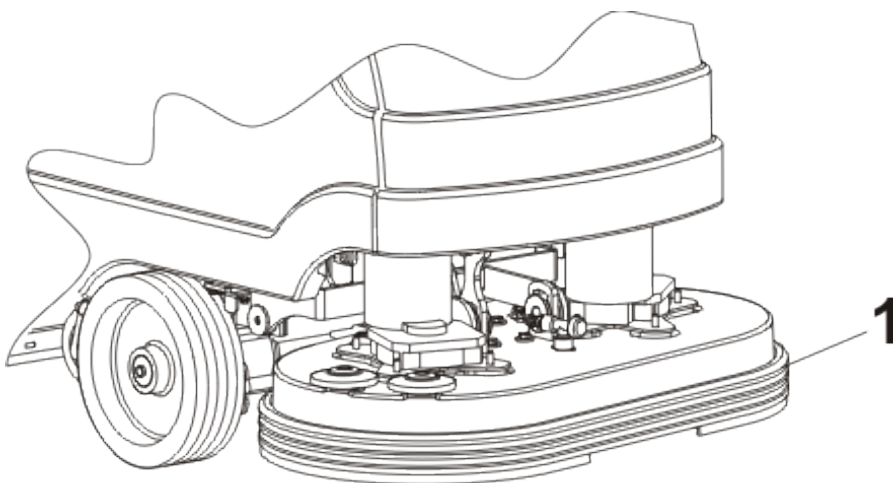

Check the splashguards periodically to make sure they are in good condition (see position 1). Replace the splashguards if damaged.



## CHECKING OR REPLACING FUSES IN THE FRONT SWITCHBOARD

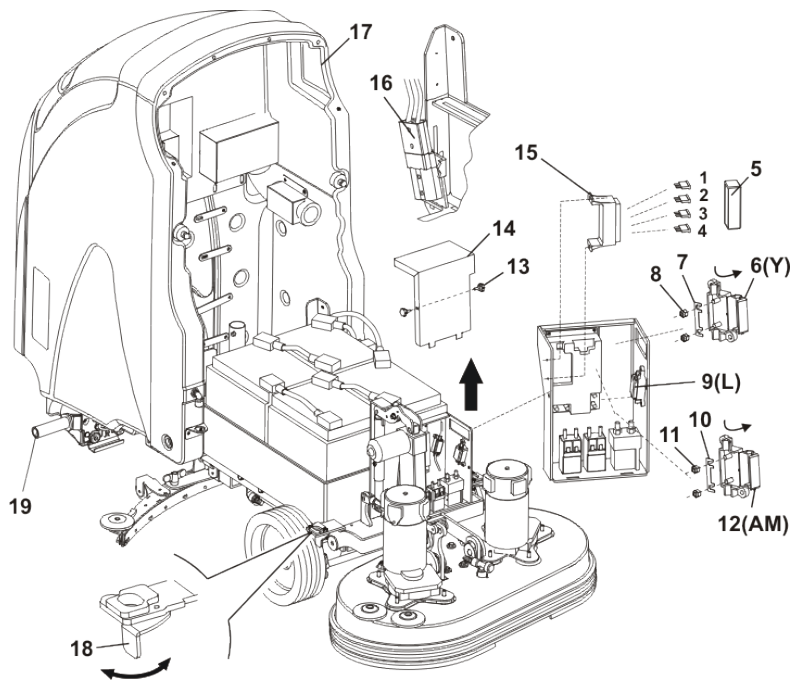

To check or replace the fuses on the switchboard proceed as follows:

- Drain both tanks into the special drainage areas;
- Bring the machine into a stop position in a flat surface area and put on the brake;
- Unplug the battery plug pos.16;
- Unfasten the tank pos.17 by pushing it inwards using the small levers pos.18 located at both ends of the machine;
- **REACH THE DRIVER'S POSITION AND LIFT THE TANK BY THE GRIPS (POS.19) PAYING ATTENTION TO HANDLE IT WITH CARE WHILE LAYING ON THE GROUND.**

- Unscrew the 2 screw knobs pos.13, pull upwards and remove the switchboard cover pos.14;
- Remove the lid pos.5 from the fuse holder pos.15;
- There are 5 fuses located in the fuse holder pos.15 and they have the following functions and features:

POSITION 1: 5 A fuse for electrical equipment protection;

POSITION 2: 7.5 A fuse for pump protection (**ONLY FOR ECO**);

POSITION 3: 30 A fuse for suction motor protection;

POSITION 4: 5 A fuse for drive system protection;

- Fuse holder pos.6 recognizable from the label Y: 40A fuse PROTECTION OF THE DRIVE SYSTEM; for substitution:

- Open the lid of the fuse holder pos.6 by pulling it up from the side indicated by the arrow;

- Unscrew the 2 fuse locking nuts pos.8;

- Replace the 40 A fuse pos.7 with a fuse of equal amperage;

- Reassemble the nuts and close the lid of the fuse holder.

- Fuse holder pos.12 recognizable from the label AM: 40A fuse holder PROTECTION OF BRUSH RELEASE FUNCTION; for substitution:

- Open the lid of the fuse holder pos.12 by pulling it up from the side indicated by the arrow;

- Unscrew the 2 fuse locking nuts pos.11;

- Replace the 40A fuse pos.10 with a fuse of equal amperage;

- Reassemble the nuts and close the lid of the fuse holder;

- Fuse holder pos.9 label L: 80A fuse - BRUSH MOTORS PROTECTION.

ATTENTION: This fuse is used by the function card to control the correct absorption of brush motors (amperometric protection). It is possible that, although the motor reducers work with a correct absorption, error E1 appears on the display.

In this case there is an oxidation of the fuse that gives a wrong reading. Please proceed as follows:

- Unscrew the 2 nuts pos.21 that fix the fuse of 80A pos.20;

- Clean the fuse holder and oil it with vaseline;

- Reassemble the nuts and close the fuse holder lid;

IMPORTANT: use exclusively the original spare fuse

Once the fuses are checked or replaced, put everything back together and bring the machine back to its operating condition.



## CHECKING OR REPLACING FUSES IN THE INSTRUMENT PANEL

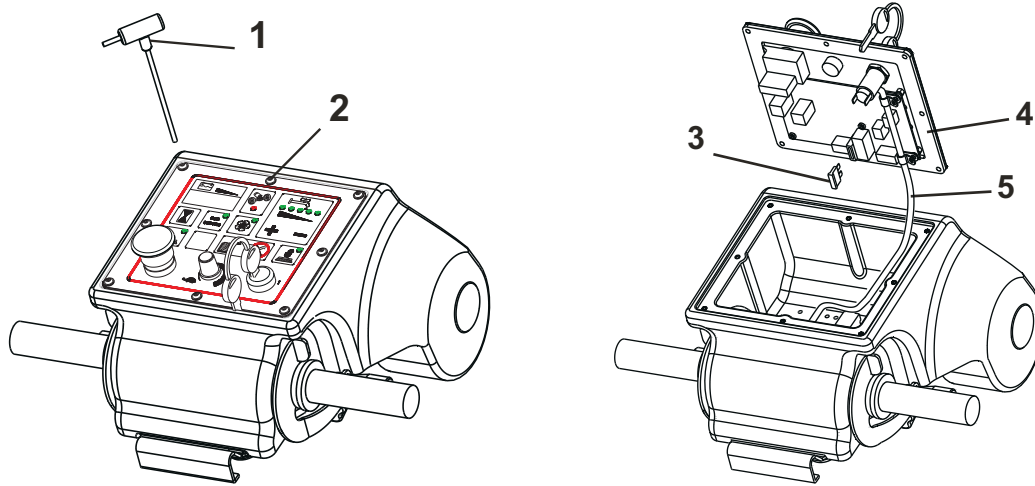

To check or replace the fuses beneath the instrument panel, proceed as follows:

- Turn off the key and unplug the battery connector as specified in the previous paragraph;
- Use a 2.5mm Allen wrench pos.1 and remove the 8 clamping screws pos.2 from the instrument panel, including the respective nylon washers;
- Carefully turn the instrument panel pos.4, follow the arrows and make sure not to jerk it as it may damage the electrical system;
- Remove the 20 A fuse pos.3, check it and replace it if necessary with a fuse of equal amperage;
- Put the instrument panel back into pos.4 and make sure to keep the cables pos.5 and the terminals away from the gearing area located inside the instrument panel;
- Put the washer and screws back into pos.2 and close the panel using the special wrench pos.1, make sure to apply enough pressure on the seal beneath the panel;



## CHECK THE SEAL ON THE COVER

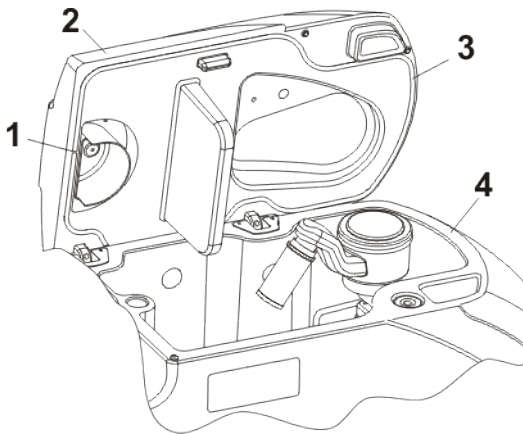

The recovery tank cover seal ensures that a proper vacuum is created inside the tank and this provides a better suction performance on the squeegee. It is very important to keep the seal intact for the machine to work properly. To clean and check the seal, proceed as follows:

- Open the cover pos.2;
- Use a piece of cloth to wipe off the seal pos.3 and make sure it is not broken or damaged;
- If the seal is damaged, remove it from the cover, mount a new seal and make sure to fit the seam of the seal into the rear position pos.1;
- Clean the area of the tank where the seal leans pos.4 when the cover is closed.



## RECHARGING BATTERIES

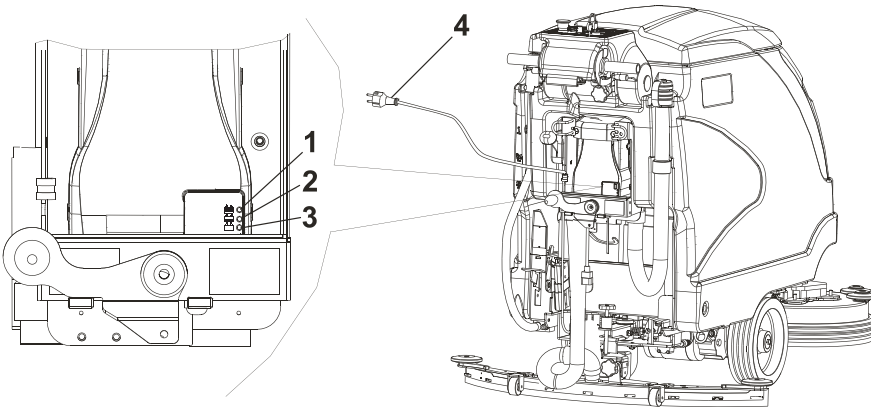

**WARNING! THE CHARGER IS PRESET FOR LEAD BATTERIES. TO MOUNT GEL OR AGM BATTERIES, BOTH THE STATUS LED AND THE CHARGER HAVE TO BE SET ACCORDING TO THE TYPE OF BATTERY WHICH IS TO BE USED. TO THIS AIM, PLEASE CONTACT EITHER A TECHNICIAN OR AN AUTHORIZED RETAILER.**

To charge the batteries follow the instructions below:

- Bring the machine into a stop position in a flat surface area, turn it off and put on the brake;
- Before charging the battery make sure to scrupulously follow the battery charger instruction manual provided with the machine;
- Uncoil the cable from the cable reel located on board the machine and connect the plug pos.4 into a standard electrical power socket. When you plug the socket, a double flash of the red led light pos.3 indicates that the charger is set to charge lead/acid batteries, otherwise a double flash of the green light pos.1 indicates that the charger is set to charge GEL-AGM-SONNENSCHN batteries. At this point the charger will make a test to check if it is necessary to charge the battery. If the battery is not connected to the charger, the red led light pos. 3 will start flashing. If the test succeeds, after a second it will start the charge of the battery (signaled by the red led light pos. 3 switched on). If, during the charging, the operator disconnects the battery from the charger, after few seconds the charger will reset itself and it will be ready to start a new charge process;
- **WARNING: WHEN PLUGGING THE BATTERY CHARGER INTO THE ELECTRICAL SOCKET, THE MACHINE FUNCTIONS ARE AUTOMATICALLY DISABLED;**
- There are 3 led lights located above the battery charger: pos. 1 GREEN led light - pos.2 YELLOW led light - pos.3 RED led light.

These led lights indicate the charging status of the battery.

The GREEN led indicates that the charging cycle is completed and the plug can be disconnected from the electrical socket and rolled back into the cable reel;

- Once the battery is charged make sure to check the electrolyte level and if necessary fill it up only using distilled water;
- The battery must always be charged in ventilated areas;
- The gas released during the charging process can cause explosions if it comes into contact with flames or sparks;
- Battery acid should never come into contact with the eyes, skin or clothes, make sure to wear goggles, gloves and appropriate clothing;
- If it comes into contact with eyes or skin, wash immediately with abundant water;
- Do not place metal objects on the batteries;
- Do not fill the batteries with sulphuric or other products;

# DIMENSIONAL TECHNICAL DRAWINGS

## E71 TRAC TRONIC - E71 ECO

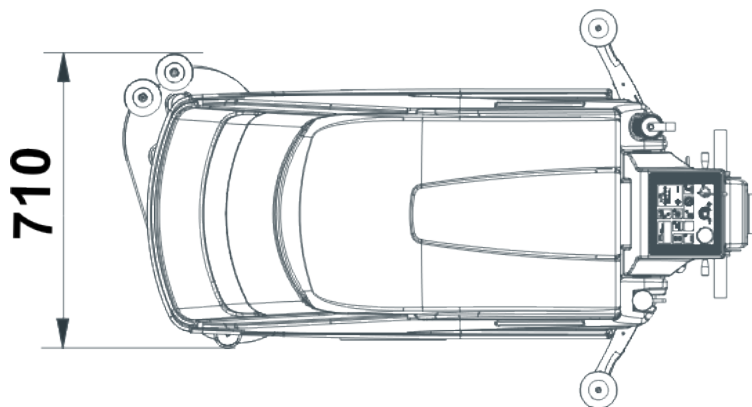
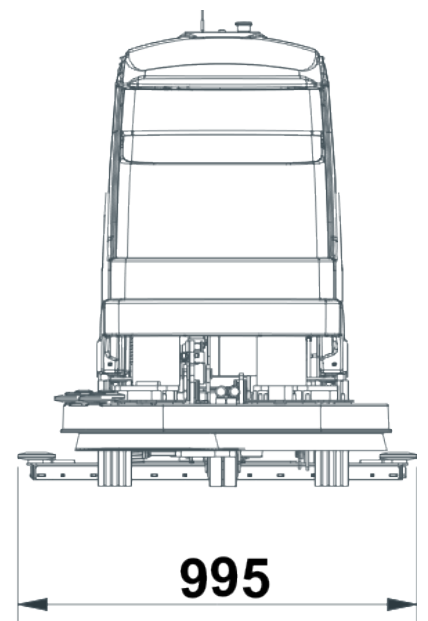
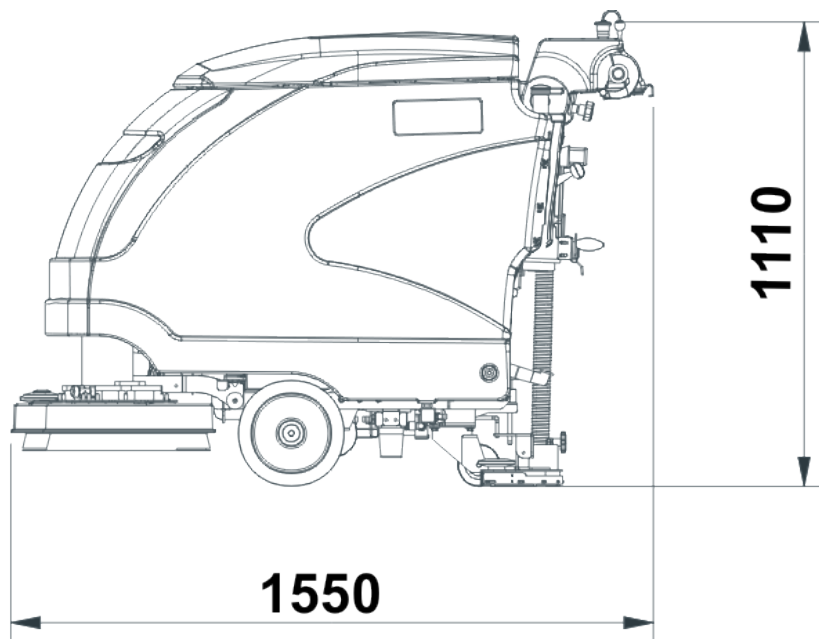

# DIMENSIONAL TECHNICAL DRAWINGS

## E81 TRAC TRONIC - E81 ECO

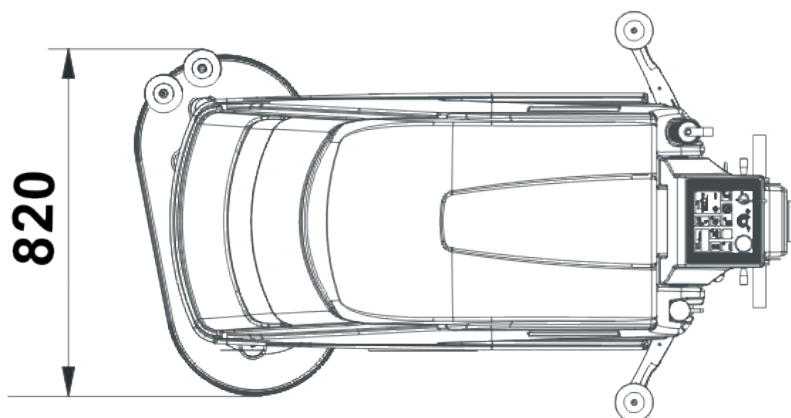
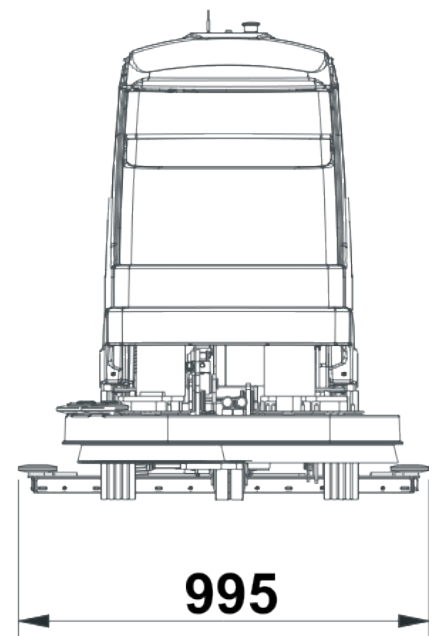
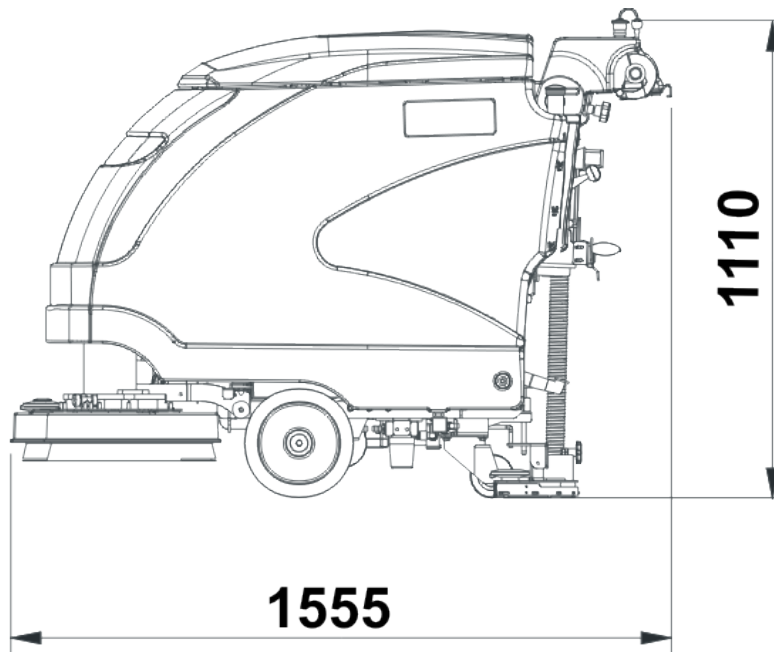

# TECHNICAL CHART

TECHNICAL SPECIFICATIONS		E71 TRAC TRONIC	E71 ECO
<b>MAIN SPECIFICATIONS</b>	Cleaning path	710 mm	
	Hourly performance	3.195 m <sup>2</sup> /h	
	Solution tank capacity	75 L	
	Recovery tank capacity	80 L	
	Forward speed	0 - 4.5 km/h	
	Maximum gradient	20 %	
	Turning radius	1.135 mm	
<b>DIMENSIONS AND WEIGHT</b>	Dimensions (without squeegee)	1.550 x 710 x 1.110 mm	
	Width (with squeegee)	995 mm	
	Weight	173 kg	
	Weight (with type A batteries)	303 kg	
	Weight (with type B batteries)	297 kg	
	Packaging dimensions	1.630 x 900 x 1.420 mm	
	Packaging weight	39 kg	
	Packaging volume	2,08 m <sup>3</sup>	
<b>BRUSHES</b>	Brush dimensions	Ø 330 - 355 mm	
	Pad size (only with pad holder)	355 mm / 14"	
	Brush motor	Gear motor: 24V - 500 W - 25A - 200 RPM - IP 20	
<b>TRACTION SYSTEM</b>	Traction type	Forward and reverse traction via gear motor, controlled electronically	
	Traction motor	24V - 300 W - 15 A	
<b>BATTERIES</b>	Batteries	4 x 6 V	
	Battery tray dimensions	390 x 542 x 300 mm	
<b>TYPE A BATTERIES</b>	Type	4 lead acid batteries 6V 240A C20 - 180A C5	
	Dimensions ea.	242 x 190 x 285 mm	
	Weight (with acid) ea.	32,6 kg	
	Autonomy (theoretical)	3 h	
<b>TYPE B BATTERIES</b>	Type	4 gel batteries 6V 180A C5	
	Dimensions ea.	242 x 190 x 285 mm	
	Weight (with acid) ea.	31 kg	
	Autonomy (theoretical)	2 h 45 min	

TECHNICAL SPECIFICATIONS		E71 TRAC TRONIC	E71 ECO
<b>BATTERY CHARGER</b>	Model	24V - 25A 100/240V, 50/60 Hz input voltage	
	Settings	Calibrated for lead acid, AGM / gel, or gel Sonnenschein batteries	
<b>SOLUTION FLOW</b>	Solution control	/	24V 120W - 2/5A
	Flow rate	0 - 3,5 L/min	Livello min 1.9 L/min, livello max 5.3 L/min
<b>VACUUM SYSTEM</b>	Vacuum motor	3 stages - 24V - 550 W - 25 A	
	Water pick up	1.250 mm/H <sub>2</sub> O	
	Standard filter	Stainless steel mesh	
<b>WHEELS</b>	Front wheel	Ø 254 x 80 mm - solid rubber, super elastic, non-marking and oil resistant. Hub made of nylon coated in polyurethane	
	Rear wheels	Ø 100 x 40+40 mm	
	Brakes	Mechanical on front wheels	
<b>SOUND LEVEL (UNI EN ISO 11201)</b>	Noise emission value LpA	71 dB (A)	
	Uncertainty KpA	2.5 dB (A)	
<b>VIBRATION LEVEL</b>	Whole-body vibration level aW	1.63 m/s <sup>2</sup>	
	Uncertainty K	-	
<b>TEMPERATURE RATING</b>	Storage temperature	+5 / +40 °C	
	Operating temperature	+5 / +40 °C	

# TECHNICAL CHART

TECHNICAL SPECIFICATIONS		E81 TRAC TRONIC	E81 ECO
<b>MAIN SPECIFICATIONS</b>	Cleaning path	810 mm	
	Hourly performance	3.645 m <sup>2</sup> /h	
	Solution tank capacity	75 L	
	Recovery tank capacity	80 L	
	Forward speed	0 - 4.5 km/h	
	Maximum gradient	20 %	
	Turning radius	1.135 mm	
<b>DIMENSIONS AND WEIGHT</b>	Dimensions (without squeegee)	1.555 x 820 x 1.110 mm	
	Width (with squeegee)	995 mm	
	Weight	178 kg	
	Weight (with type A batteries)	308 kg	
	Weight (with type B batteries)	302 kg	
	Packaging dimensions	1.630 x 900 x 1.420 mm	
	Packaging weight	39 kg	
	Packaging volume	2,08 m <sup>3</sup>	
<b>BRUSHES</b>	Brush dimensions	Ø 380 - 395 mm	
	Pad size (only with pad holder)	406 mm / 16"	
	Brush motor	Gear motor: 24V - 500 W - 25A - 200 RPM - IP 20	
<b>TRACTION SYSTEM</b>	Traction type	Forward and reverse traction via gear motor, controlled electronically	
	Traction motor	24V - 300 W - 15A	
<b>BATTERIES</b>	Batteries	4 x 6 V	
	Battery tray dimensions	390 x 542 x 300 mm	
<b>TYPE A BATTERIES</b>	Type	4 lead acid batteries 6V 240A C20 - 180A C5	
	Dimensions ea.	242 x 190 x 285 mm	
	Weight (with acid) ea.	32,6 kg	
	Autonomy (theoretical)	2 h 45 min	
<b>TYPE B BATTERIES</b>	Type	4 gel battery 6V 180A C5	
	Dimensions ea.	242 x 190 x 285 mm	
	Weight (with acid) ea.	31 kg	
	Autonomy (theoretical)	2 h 30 min	

TECHNICAL SPECIFICATIONS		E81 TRAC TRONIC	E81 ECO
<b>BATTERY CHARGER</b>	Model	24V - 25A 100/240V, 50/60 Hz input voltage	
	Settings	Calibrated for lead acid, AGM / gel, or gel Sonnenschein batteries	
<b>SOLUTION FLOW</b>	Solution control	/	24V 120W - 2/5A
	Flow rate	0 - 3,5 L/min	Livello min 1.9 L/min, livello max 5.3 L/min
<b>VACUUM SYSTEM</b>	Vacuum motor	3 stadi - 24V - 550 W - 25 A	
	Water pick up	1.250 mm/H <sub>2</sub> O	
	Standard filter	Stainless steel mesh	
<b>WHEELS</b>	Front wheel	Ø 254 x 80 mm - solid rubber, super elastic, non-marking and oil resistant. Hub made of nylon coated in polyurethane	
	Rear wheels	Ø 100 x 40+40 mm	
	Brakes	Mechanical on front wheels	
<b>SOUND LEVEL (UNI EN ISO 11201)</b>	Noise emission value LpA	71 dB (A)	
	Uncertainty KpA	2.5 dB (A)	
<b>VIBRATION LEVEL</b>	Whole-body vibration level aW	1.63 m/s <sup>2</sup>	
	Uncertainty K	-	
<b>TEMPERATURE RATING</b>	Storage temperature	+5 / +40 °C	
	Operating temperature	+5 / +40 °C	

# SERVICE AND MAINTENANCE RECORDS

1°

## SERVICE AND MAINTENANCE RECORD

**TO 100 HOURS**

**DATE**

DAY	MONTH	YEAR	WORKING HOURS

- Check that the batteries clamps are not loosen or oxidized
- Check the cover gasket
- Check the vacuum motor filter
- Check the brake
- Check, and if necessary replace, the fuses
- Check the brushes and the components of the brush plate
- Check, and if necessary rotate or replace, the squeegee blades
- Check the adjusting/closing detergent solution tap
- Check the pump (only for ECO version), the detergent solution filter, the solenoid valve related to the detergent solution circuit (only for ECO version) and the fitting outgoing from the pump (only for ECO version)
- Check the drainpipes of the solution and recovery tanks
- Check that the vacuum pipe on the squeegee is not broken or clogged
- Proceed with the cleaning of the ECO system device and its components (only for ECO version, follow the guidelines in the manual)
- Check the squeegee lifting lever and its cable
- Test the machine in all its operating functions

**THE SERVICE WAS CARRIED OUT ON:**

**NAME:**

**SURNAME:**

**SIGNATURE:**

**STAMP OF DEALER WHO CARRIED OUT SERVICE**

**NOTES**

**2°**

**SERVICE AND MAINTENANCE RECORD**

**TO 200 HOURS**

**DATE**

DAY	MONTH	YEAR	WORKING HOURS

- Check that the batteries clamps are not loosen or oxidized
- Check the cover gasket
- Check the vacuum motor filter
- Check the brake
- Check, and if necessary replace, the fuses
- Check the brushes and the components of the brush plate
- Check, and if necessary rotate and replace, the squeegee blades
- Check the adjusting/closing detergent solution tap
- Check the pump (only for ECO version), the detergent solution filter, the solenoid valve related to the detergent solution circuit (only for ECO version) and the fitting outgoing from the pump (only for ECO version)
- Check the drainpipes of the solution and recovery tanks
- Check that the vacuum pipe of the squeegee is not broken or clogged
- Proceed with the cleaning of the ECO system device and its components (only for ECO version, follow the guidelines in the manual)
- Check the squeegee lifting lever and its cable
- Test the machine in all its operating functions

**THE SERVICE WAS CARRIED OUT ON:**

**NAME:**

**SURNAME:**

**SIGNATURE:**

<b>STAMP OF DEALER WHO CARRIED OUT SERVICE</b>
--

<p style="text-align: center;"><b>NOTES</b></p>
---

**3°**

## SERVICE AND MAINTENANCE RECORD

**TO 300 HOURS**

**DATE**

DAY	MONTH	YEAR	WORKING HOURS

- Check that the batteries clamps are not loosen or oxidized
- Check the cover gasket
- Check the vacuum motor filter
- Check the brake
- Check, and if necessary replace, the fuses
- Check the brushes and the components of the brush plate
- Check, and if necessary rotate and replace, the squeegee blades
- Check the adjusting/closing detergent solution tap
- Check the pump (only for ECO version), the detergent solution filter, the solenoid valve related to the detergent solution circuit (only for ECO version) and the fitting outgoing from the pump (only for ECO version)
- Check the drainpipes of the solution and recovery tanks
- Check that the vacuum pipe of the squeegee is not broken or clogged
- Proceed with the cleaning of the ECO system device and its components (only for ECO version, follow the guidelines in the manual)
- Check the squeegee lifting lever and its cable
- Test the machine in all its operating functions

**THE SERVICE WAS CARRIED OUT ON:**

**NAME:**

**SURNAME:**

**SIGNATURE:**

**STAMP OF DEALER WHO CARRIED OUT SERVICE**

**NOTES**

**4°**

## SERVICE AND MAINTENANCE RECORD

**TO 400 HOURS**

**DATE**

DAY	MONTH	YEAR	WORKING HOURS

- Check that the batteries clamps are not loosen or oxidized
- Check the cover gasket
- Check the vacuum motor filter
- Check the brake
- Check, and if necessary replace, the fuses
- Check the brushes and the components of the brush plate
- Check, and if necessary rotate and replace, the squeegee blades
- Check the adjusting/closing detergent solution tap
- Check the pump (only for ECO version), the detergent solution filter, the solenoid valve related to the detergent solution circuit (only for ECO version) and the fitting outgoing from the pump (only for ECO version)
- Check the drainpipes of the solution and recovery tanks
- Check that the vacuum pipe of the squeegee is not broken or clogged
- Proceed with the cleaning of the ECO system device and its components (only for ECO version, follow the guidelines in the manual)
- Check the squeegee lifting lever and its cable
- Test the machine in all its operating functions

**THE SERVICE WAS CARRIED OUT ON:**

**NAME:**

**SURNAME:**

**SIGNATURE:**

**STAMP OF DEALER WHO CARRIED OUT SERVICE**

**NOTES**

5°

# SERVICE AND MAINTENANCE RECORD

**TO 500 HOURS**

**DATE**

DAY	MONTH	YEAR	WORKING HOURS

CHECK AND REMOVE THE MOTOR CARBON BRUSHES ONE AT A TIME SO AS NOT TO INVERT THEM. THE MOTOR CARBON BRUSHES SETTLE AND WEAR DIFFERENTLY THE ONE FROM THE OTHER, CONSEQUENTLY IF THESE ARE INSPECTED AND PUT BACK ON AGAIN BECAUSE THEY ARE NOT FULLY WORN, THEY MUST BE REFITTED IN THE SAME POSITION.

**VACUUM MOTOR**

Check the carbon brushes and replace them if they are shorter than 10 mm. Length of new motor carbon brush: 26.8 mm. N°2 carbons (cod 640337) for each motor;

**TRACTION GEAR REDUCTION MOTOR**

Check the carbon brushes and replace them if they are shorter than 10.5 mm. Length of new motor carbon brush: 19 mm. N°4 carbons (cod 64082) for each motor (1 kit);

**BRUSH GEAR REDUCTION MOTOR**

Check the carbon brushes and replace them if they are shorter than 11.5 mm. Length of new motor carbon brush: 19 mm. N°4 carbons (cod 640281) for each motor;

- Check that the batteries clamps are not loosen or oxidizes
- Check the cover gasket
- Check the vacuum motor filter
- Check the brake
- Check, and if necessary replace, the fuses
- Check the brushes and the components of the brush plate
- Check, and if necessary rotate or replace, the squeegee blades
- Check the adjusting/closing detergent solution tap
- Check the pump (only for ECO version), the detergent solution filter, the solenoid valve related to the detergent solution circuit (only for ECO version) and the fitting outgoing from the pump (only for ECO version)
- Check the drainpipes of the solution and recovery tanks
- Check that the vacuum pipe of the squeegee is not blocked or clogged
- Proceed with the cleaning of the Eco system device and its components (only for ECO version, follow the guidelines in the manual)
- Check the wheel bearings
- Check the squeegee lifting lever and its cable
- Test the machine in all its operating functions

**THE SERVICE WAS CARRIED OUT ON:**

**NAME:**

**SURNAME:**

**SIGNATURE:**

**STAMP OF DEALER WHO CARRIED OUT SERVICE**

**NOTES**

<b>UP TO 600 HOURS AS FOR 100 HOURS</b>	<b>DATE</b>	<b>DAY</b>	<b>MONTH</b>	<b>YEAR</b>	<b>WORK. HOURS</b>
THE SERVICE WAS CARRIED OUT ON:		<b>STAMP OF DEALER WHO CARRIED OUT SERVICE</b>			
NAME:					
SURNAME:					
SIGNATURE:					

<b>UP TO 700 HOURS AS FOR 200 HOURS</b>	<b>DATE</b>	<b>DAY</b>	<b>MONTH</b>	<b>YEAR</b>	<b>WORK. HOURS</b>
THE SERVICE WAS CARRIED OUT ON:		<b>STAMP OF DEALER WHO CARRIED OUT SERVICE</b>			
NAME:					
SURNAME:					
SIGNATURE:					

<b>UP TO 800 HOURS AS FOR 300 HOURS</b>	<b>DATE</b>	<b>DAY</b>	<b>MONTH</b>	<b>YEAR</b>	<b>WORK. HOURS</b>
THE SERVICE WAS CARRIED OUT ON:		<b>STAMP OF DEALER WHO CARRIED OUT SERVICE</b>			
NAME:					
SURNAME:					
SIGNATURE:					

<b>UP TO 900 HOURS AS FOR 400 HOURS</b>	<b>DATE</b>	<b>DAY</b>	<b>MONTH</b>	<b>YEAR</b>	<b>WORK. HOURS</b>
THE SERVICE WAS CARRIED OUT ON:		<b>STAMP OF DEALER WHO CARRIED OUT SERVICE</b>			
NAME:					
SURNAME:					
SIGNATURE:					

<b>UP TO 1000 HOURS AS FOR 500 HOURS</b>	<b>DATE</b>	<b>DAY</b>	<b>MONTH</b>	<b>YEAR</b>	<b>WORK. HOURS</b>
THE SERVICE WAS CARRIED OUT ON:		<b>STAMP OF DEALER WHO CARRIED OUT SERVICE</b>			
NAME:					
SURNAME:					
SIGNATURE:					

<b>NOTES</b>
--------------

# TROUBLE-SHOOTING CHART

## WARNING!

ANY TYPE OF SERVICE OPERATION OR TEST, WITH THE EXCEPTION OF THOSE SHOWN IN THE ENGINE'S MANUAL OR THE BATTERY'S MANUAL, MUST BE CARRIED OUT BY AUTHORIZED SERVICE CENTRES ONLY.

<b>BEFORE ANY INTERVENTIONS CHECK THE CORRECT VOLTAGE OF THE BATTERY: 24 V</b>		
<b>PROBLEM</b>	<b>CAUSE</b>	<b>SOLUTION</b>
The battery gets discharged	Either exhaust or broken elements	Replace it
The display of the control card does not switch on when inserting the key	Flat or worn out battery	Recharge it
	Fuse burn out	Replace it
	Emergency switch pressed	Unblock it
	Battery mobile connector disconnected	Connect it
	Key operated switch broken	Replace it
	Control board is broken	Replace it
When you press the brush button the brush plate can't be lowered	Flat or worn out battery	Recharge it
	Faulty actuator	Replace it
	Faulty card	Replace it
	Actuator control module on the control board is broken	Replace it
	Material underneath the brush plate thus preventing it from lowering	Remove the material as to unlock the brush plate
The brush motor does not rotate	Flat or worn out battery	Recharge it
	Electric remote switch is broken	Replace it
	Control board is broken	Replace it
	Amperometric protection for over-absorption of the motor ON THE DISPLAY IT WILL APPEAR THE INDICATION "EI"	Follow the instructions E1
	Carbons are worn out	Replace them
	Blown fuse	Replace it
	Faulty motors	Replace it
By pressing the "extra-pressure" button the brush plate does not get into correct position	Faulty actuator	Replace it
	Faulty card	Replace it
	Actuator control module on the control board is broken	Replace it
The brush release function does not work	The brush function is still on	Disable the brush function
	The machine is in motion	Release the drive button
	40A Fuse (FUSEHOLDER 'AM') for protection of brush release is broken	Replace it
	Release remote switch is broken	Replace it
	Control board is broken	Replace it

PROBLEM	CAUSE	SOLUTION
The drive does not work	Brake is engaged	Disengage it
	Flat or worn out battery	Recharge it
	Key disconnected	Insert it
	Traction fuse 40A is faulty (fuseholder "Y")	Replace it
	Protection traction fuse 5A is faulty (fuseholder pos.5)	Replace it
	Motor gear is faulty	Replace it
	Motor carbons are worn out	Replace them
	Electronic control board is broken	Replace it
	Microswitch in the control panel is broken	Replace it
	Main potentiometer is faulty	Replace it
Potentiometer on control panel (V-MAX) is faulty	Replace it	

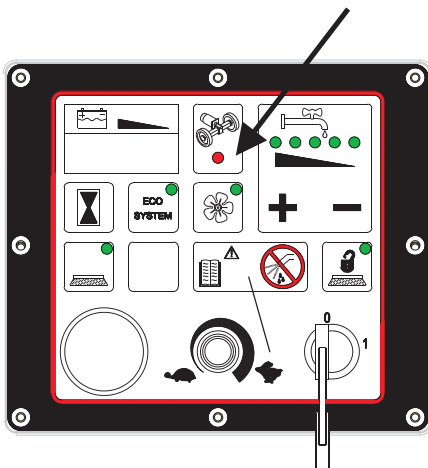

### DIAGNOSIS FOR TRACTION CARD LED FLASHINGS

The red warning light on the control board card indicating - when switched off- the correct functioning of the drive electric control is blinking

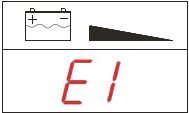

SWITCHED OFF: NO ERRORS, NORMAL WORKING CONDITIONS	
1 FLASHING: forward speed microswitch engaged when starting up the machine	<ul style="list-style-type: none"> <li>• Pull the drive control switch in 0 position</li> <li>• Check that the switch is correctly placed into 0 position</li> <li>• Check the microswitch on the drive control</li> </ul>
2 FLASHINGS: reverse speed microswitch engaged when starting up the machine	<ul style="list-style-type: none"> <li>• Check the microswitch on the drive control</li> </ul>
3 FLASHINGS: the potentiometer signal is off	Check the cables of the potentiometer
4 FLASHINGS: the potentiometer is not working	<ul style="list-style-type: none"> <li>• Pull the drive control switch in 0 position.</li> <li>• Check that the switch is correctly placed into 0 position</li> <li>• Check the microswitch on the drive control</li> </ul>
5 FLASHINGS: thermal protection	Wait for some minutes before starting and checking the absorptions of the motor
6 FLASHINGS: <ul style="list-style-type: none"> <li>• the power fuse is faulty</li> <li>• faulty power component on the starting card</li> </ul>	<ul style="list-style-type: none"> <li>• Replace the power fuse</li> <li>• Replace the traction board</li> </ul>
7 FLASHINGS: overcurrent	Cables from the battery to the traction board or from traction board to the engine are loose, oxidized or not properly connected. Check the cables.
8 FLASHINGS: either the power fuse or the power relay is faulty	Check that the 30A power fuse (pos. 4 on the fuse-holder) from + battery till the traction board is OK and that the battery and motor wires are properly connected. If necessary, replace the traction board.
9 FLASHINGS: under voltage (< 19 V)	Check and charge the batteries
10 FLASHINGS: overvoltage	Battery tension higher than 45V
11 FLASHINGS: amperometric protection of the traction motor: the motor has worked for more than 10 seconds above the maximum nominal current value (15 A)	Verify that the differential spins freely. Check with an ammeter the motor consumption. For the correct consumption values refer to the technical chart.
13 FLASHINGS: temporary power supply interruption	Attention! If 13 flashes appear, the operator should first ensure that at least 3-4 seconds have passed between turning off the machine (key in position 0) and turning on the machine (key in position 1). This is the time required for the traction electronic card to activate. Otherwise 13 flashes are generated. If the problem persists, it could be a bad electrical contact issue: check that the in the ignition switch, fuses and the 16 poles connector of the chopper there isn't any intermittent contact. If the problem persists again replace the chopper.
14 FLASHINGS: failed data reading	Remove the key and put the service switch in 0 position. If necessary, replace the traction board.

PROBLEM	CAUSE	SOLUTION
The suction motor does not work	Flat batteries	Recharge them
	30A suction motor fuse worn out	Replace the fuse pos. 3 (of the fuse holder)
	Electric remote switch is broken	Replace it
	Vacuum motor disconnected	Check the motor wiring
	Vacuum motor is faulty	Replace it
	Vacuum motor carbons are worn out	Replace them
	Control board is broken	Replace it
Not enough suction on the squeegee	Recovery tank is full	Empty it
	Float on the recovery tank	Switch off the vac. motor and unblock the float ball
	Lid on the exhaust pipe is open	Tight the lid
	Vacuum pipe disconnected	Verify that it is mounted properly
	Vacuum pipe is clogged	Clean both the pipe and the vacuum hose on the tank
	Faulty vacuum pipe	Replace the pipe
	Dirty squeegee	Clean the squeegee
	The squeegee is not adjusted properly	Adjust inclination and pressure
	Material tangled with the squeegee blades	Clean the blades
	Squeegee blades either broken or worn out	Reverse the blades or replace them
	The tank is either open or not properly closed	Close it
	Damaged lid gasket	Replace the gasket
	Faulty suction motor	Replace/check the motor
Flat batteries	Recharge them	
Not enough water flow on the brush	Solution tank is empty	Fill the tank
	Tap is closed	Open the tap
	Faulty electrovalve of the detergent solution.	Replace it
	Faulty ECO-SYSTEM electrovalve of the detergent solution <b>(ECO)</b>	Replace it
	Clogged detergent solution filter	Clean the filter
	The solution pipe from the tank to the brush is clogged	Make sure there is no incrustations
	Faulty 7.5A pump fuse <b>(ECO)</b>	Replace fuse pos.2 of the fuse-holder
	Worn out carbons of the pump motor <b>(ECO)</b>	Replace them
	Pump either clogged or faulty <b>(ECO)</b>	Check the pump /replace it
	In ECO-SYSTEM mode not enough water in the recovery tank <b>(ECO)</b>	Verify the water level
	ECO-SYSTEM filter clogged <b>(ECO)</b>	Clean it
	Outlet pump connection clogged <b>(ECO)</b>	Clean the connection

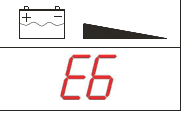
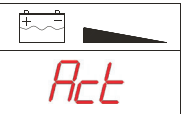
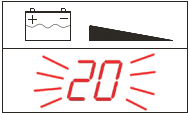
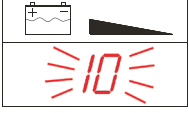
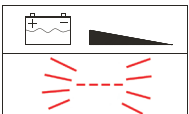
PROBLEM	CAUSE	SOLUTION
	<p>Amperometric protection for overabsorption of the brush motor. The led light of the brush bottom flashes for 1 minute and then the writing E1 appears, the brushes will stop lifting the plate.</p>	<p>Stop the machine and start it again. If the problem persists, check out the cause of over-absorption (threads or any other material which might get tangled with the brush; the brush is not suitable for the type of floor) If the alarm persists, check if there is any oxidation in the 80 A fuse that can give a wrong reading. Check pag. 34, 80 A fuse (pos. 20) placed inside the fuse holder L pos. 9.</p>
	<p>Alarm: the contact of both the actuator limit switches is open.</p>	<p>Make sure that there are no foreign bodies preventing the brush plate from functioning. If the problem persists, contact either a retailer or technician.</p>
	<p>Alarm: the final position of the actuator is not reached within the max. lapse of time (10secs)</p>	<p>Make sure that there are no foreign bodies preventing the brush plate from functioning. If the problem persists, get in touch with either a retailer or a technician.</p>
	<p>Alarm: when starting up the machine, pos. 0 is not reached within the max. lapse of time (10secs).</p>	<p>Make sure that there are no foreign bodies preventing the brush plate from functioning. If the problem persists, contact either a retailer or a technician.</p>
	<p>That is not an alarm but rather a warning signal indicating that the brush plate is not in raised position when starting up the machine. The machine requires the brush plate to be lowered before being used for any other operation.</p>	<p>Wait for a few seconds till the brush plate has been raised completely.</p>
	<p>1° The battery charge level is too much low. Upon reaching level 20 the number on the display shall start blinking and the brush function will be disabled, lifting the plate</p>	<p>Complete drying. Empty the recovery tank and recharge the batteries.</p>
	<p>2° The battery charge level is too much low. Upon reaching level 10 the number on the display shall start blinking and the suction function will be disabled.</p>	<p>Lift the squeegee, empty the recovery tank and recharge the batteries</p>
	<p>3° The battery charge level is too much low. When 4 blinking dashes appear on the display unit, it means that the minimum discharge threshold of the battery has reached its maximum level and if the battery is used any further it will cause irreparable damages. At this point, the forward drive will no longer operate.</p>	<p>The machine must be taken to the tank drainage area manually in order to charge the batteries.</p>

## EU DECLARATION OF CONFORMITY

according to Annex II A of the Machinery Directive 2006/42/CE

The manufacturer that places this product on the market:

**EUREKA S.p.A. Unipersonale**  
VIALE DELL'ARTIGIANATO 30/32, 35013 CITTADILLA (PD) - ITALY

formally declares that the product:

**Scrubber E71 TRAC TRONIC**  
**Scrubber E71 ECO**  
**Scrubber E81 TRAC TRONIC**  
**Scrubber E81 ECO**

complies with the following EU Directives:

**2006 / 42 / CE**  
**2014 / 30 / UE**  
**2014 / 35 / UE**  
**2011/ 65 / UE + 2015 / 863**  
**2009 / 125 / CE**

Machinery Directive, Annex 1  
Electromagnetic Compatibility (EMC) Directive  
Low Voltage Directive  
RoHS 3 Directive  
Energy-Related Products (ErP) Directive

The following harmonised and technical standards have been applied:

<b>EN ISO 12100:2010</b>	Safety of machinery - General principles for design - Risk assessment and risk reduction.
<b>EN 60335-1:2013</b>	Household and similar electrical appliances - Safety - Part 1: General requirements.
<b>EN 60335-2-72:2016</b>	Household and similar electrical appliances - Safety - Part 2: Particular requirements for floor treatment machines with or without traction drive, for commercial use.
<b>EN 55014-1:2019</b>	Electromagnetic compatibility - Requirements for household appliances - electric tools and similar apparatus - Part 1: Emission.
<b>EN 55014-2:2015</b>	Electromagnetic compatibility - Requirements for household appliances, electric tools and similar apparatus - Part 2: Immunity - Product family standard.
<b>EN 61000-6-2:2016</b>	Electromagnetic compatibility (EMC) - Part 6-2: Generic standards - Immunity standard for industrial environments.
<b>EN 61000-6-4:2018</b>	Electromagnetic compatibility (EMC) - Part 6-4: Generic standards - Emission standard for industrial environments.
<b>EN 62233:2008</b>	Measurement methods for electromagnetic fields of household appliances and similar apparatus with regard to human exposure.

Legal representative and person authorized to compile the technical file: Antonio Barile

Cittadilla, 15/12/2023

EUREKA S.p.A  
(Legal representative)

