

# INSTRUCTION MANUAL

## RIDER 1201 EB



EN

Instruction manual  
(Original instruction)



Attention: Read the instruction before use  
the machine





# CONTENT INDEX

<b>PRESENTATION</b> .....	<b>4</b>
<b>ATTENTION!</b> .....	<b>4</b>
<b>MACHINE IDENTIFICATION</b> .....	<b>5</b>
<b>GENERAL WARNINGS AND ADVICE</b> .....	<b>6</b>
<b>CLEANING AND MAINTENANCE</b> .....	<b>7</b>
<b>SAFETY PRECAUTIONS FOR OPERATORS AND TECHNICIANS</b> .....	<b>7</b>
<b>DISPOSAL</b> .....	<b>8</b>
<b>TRANSPORT AND UNPACKING</b> .....	<b>9</b>
<b>MACHINE DESCRIPTION</b> .....	<b>10</b>
<b>PRIMARY FUNCTIONS AND CONTROLS</b> .....	<b>11</b>
<b>USING THE MACHINE</b> .....	<b>14</b>
OPERATION.....	14
STARTING THE MACHINE .....	14
TRANSPORTING ONLY .....	14
TURNING OFF THE MACHINE.....	14
RECHARGING BATTERY .....	15
REPLACING THE FUSES .....	15
BATTERY CABLE LENGTH .....	16
SETTING THE CHARGE INDICATOR.....	16
VACUUM CLOSING CONTROL.....	17
FILTER SHAKER CONTROL .....	17
SIDE BRUSH CONTROL.....	17
REPLACING THE SIDE BRUSH.....	17
EMPTYING THE DIRT CONTAINER .....	18
ADJUSTING THE MAIN BRUSH .....	18
MAIN BRUSH CONTROL .....	19
REPLACING THE MAIN BRUSH .....	19
REPLACING THE RIGHT SIDE RUBBER FLAP.....	19
REPLACING THE REAR SIDE RUBBER FLAP .....	19
REPLACING THE LEFT SIDE RUBBER FLAP .....	20
REPLACING THE FRONT RUBBER FLAP .....	20
REPLACING THE FILTER .....	20
<b>DIMENSIONAL DRAWINGS</b> .....	<b>21</b>
<b>TECHNICAL CHART</b> .....	<b>22</b>
<b>SERVICE AND MAINTENANCE RECORDS</b> .....	<b>24</b>
<b>TROUBLE-SHOOTING CHART</b> .....	<b>30</b>
<b>EU DECLARATION OF CONFORMITY</b> .....	<b>33</b>

# PRESENTATION

*Our company, a leader in the production of industrial cleaning machines, is delighted to have you among the owners of this sweeper and is sure you will be fully satisfied with it. We are sure that during its use, you will see the quality, robustness and possibilities of use it has to offer. This sweeper is suitable for private, industrial or public use. This manual describes the various installation operations, controls and maintenance interventions necessary to maintain perfect efficiency of your sweeper. These are normal maintenance operations that any operator can carry out using devices normally available in a company. For particular works, please contact specialist staff.*

OUR COMPANY AIMS TO CONSTANTLY IMPROVE ITS PRODUCTS AND RESERVES THE RIGHT TO MAKE CHANGES AND IMPROVEMENTS WHEN NECESSARY WITHOUT ANY OBLIGATION TO UPGRADE PREVIOUSLY SOLD MACHINES.

## ATTENTION!

### **THE MACHINE IS NOT CERTIFIED FOR ON-ROAD USE.**

BEFORE USING THE MACHINE OR CARRYING OUT ANY OPERATION ON IT, ALL THE PROCEDURES AND WARNINGS DESCRIBED IN THIS MANUAL MUST BE READ AND UNDERSTOOD. STRICT COMPLIANCE WITH THE REGULATIONS AND THE INSTRUCTIONS CONTAINED IN THIS MANUAL, COMBINED WITH THE OPERATOR'S ATTENTION AND CAUTION, WILL BE THE BEST GUARANTEE AGAINST ACCIDENTS THAT CAN OCCUR IN THE WORKPLACE.

SWEEPERS ARE DESIGNED TO PROVIDE UTMOST SAFETY IF USED ACCORDING TO INSTRUCTIONS. THIS MACHINE IS INTENDED FOR COMMERCIAL USE, FOR EXAMPLE IN HOTELS, IN SCHOOLS, IN HOSPITALS, IN FACTORIES, IN SHOPS, IN OFFICES AND IN BUSINESSES.

THIS MACHINE IS NOT INTENDED FOR USE BY PEOPLE (INCLUDING CHILDREN) WITH REDUCED PHYSICAL, SENSORY OR PSYCHOLOGICAL CAPACITY, OR WITH LACK OF EXPERIENCE AND KNOW-HOW. CHILDREN SHOULD BE MONITORED TO ENSURE THEY DO NOT USE THE EQUIPMENT TO PLAY ON.

THE USER MANUAL IS AN INTEGRAL PART OF THE SWEEPER AND MUST ACCOMPANY IT UP TO ITS DEMOLITION.

PURSUANT TO DIRECTIVE 2006/42 EC, AND DPR 459 ON 24/07/1996 AND SUBSEQUENT UPDATES, IT IS MADE KNOWN THAT: OPERATOR IS INTENDED AS THE PERSON OR PEOPLE RESPONSIBLE FOR INSTALLING, OPERATING, ADJUSTING, CARRYING OUT ROUTINE MAINTENANCE, CLEANING, REPAIRING AND TRANSPORTING THE MACHINE.

THIS COMPANY CANNOT BE HELD LIABLE FOR PROBLEMS, BREAKAGES, ACCIDENTS OR OTHER ISSUES DUE TO LACK OF KNOW-HOW OR NON-APPLICATION OF THE PROCEDURES CONTAINED IN THIS MANUAL, OR DUE TO IMPROPER USE OF THE MACHINE.

THIS COMPANY ALSO CANNOT BE HELD LIABLE FOR CHANGES, INSTALLATION OF PARTS AND/OR ACCESSORIES WITHOUT PRIOR AUTHORISATION.



### **EMERGENCY SITUATIONS**

**IN THE EVENT OF FIRE, ONLY USE POWDER EXTINGUISHERS  
IF OCCURS ANY ABNORMAL BEHAVIOR (UNCONTROLLED SPEED INCREASE,  
OVERHEATING, ...) TURN OFF THE MACHINE IMMEDIATELY**

# MACHINE IDENTIFICATION

The machine and manufacturer are identified through three plates on the rear of the dirt container.

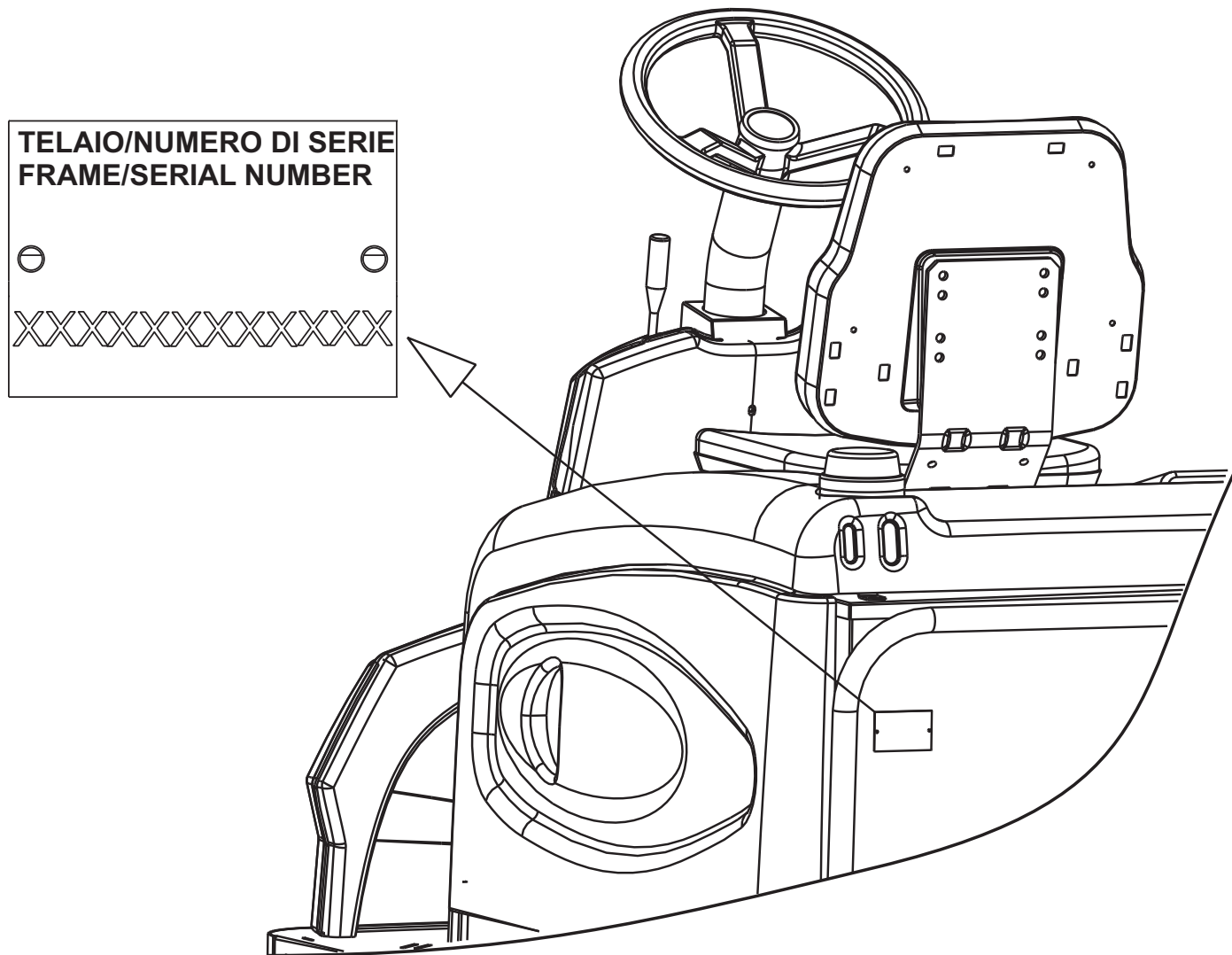

REFER TO THESE DETAILS TO ORDER SPARE PARTS OR WHEN SENDING ANY REQUEST TO THE MANUFACTURER.

The sweepers comply with EEC directives and display the CE logo.

# GENERAL WARNINGS AND ADVICE

## DANGER - ATTENTION SIGNS



THIS SYMBOL HIGHLIGHTS ALL THE OPERATIONS THAT REPRESENT A SITUATION OF POTENTIAL DANGER FOR THE OPERATOR.  
THEREFORE, PROCEED IN COMPLIANCE WITH THE CONDITIONS HIGHLIGHTED BY THIS SYMBOL

---



DANGER OF BURNS DUE TO HOT SURFACES

---



COMPULSORY USE OF ACOUSTIC PROTECTION  
IN PARTICULAR ENVIRONMENTS OR WORKING CONDITIONS, CERTAIN SWEEPER MODELS COULD PRODUCE AN ACOUSTIC EFFECT THAT WOULD ADVISE USE OF PROTECTIVE GUARDS

---



USE OF GLOVES COMPULSORY

---



USE OF GOGGLES COMPULSORY

---



ATTENTION: MOVING PARTS, RISK OF TRAPPING HANDS

---



ATTENTION: DO NOT WET  
THE DEVICES MARKED WITH THIS INDICATION MUST NOT GET WET  
(THEY ARE NORMALLY ELECTRICAL COMPONENTS)

---

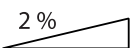

WARNING: DO NOT USE TO CLEAN SURFACES WITH GRADIENTS OVER THAT INDICATED ON THE MACHINE



## CLEANING AND MAINTENANCE

Machine cleaning must be carried out by staff correctly trained for the purpose, who know the controls to bypass energy sources and are familiar with the characteristics of the machine to avoid dangerous situations.

Clean the coverings of the machine, the panels and the controls with a cloth soaked in water or detergent solution.

No solvents must be used such as petrol, alcohol, etc.

Have specialist staff clean the electrical components who should use non-corrosive products, suitable for electrical circuits.

Maintenance of the machine must be carried out by specialist staff with in-depth knowledge of the machine and its components.

Any maintenance and cleaning must be carried out with the machine off, with all the mechanisms stopped, the hot parts cooled and the battery disconnected.

When using compressed air guns for cleaning, protect eyes and ears.

## STORAGE OF THE MACHINE

If the machine is unused for long periods of time, it is essential to:

- Store the machine in a protected location
- Clean the machine inside and out
- Keep the brushes raised to avoid the bristles getting damaged
- Keep the dirt container lowered
- Secure the machine with the parking brake
- Remove the key
- Disconnect the battery clamps



## SAFETY PRECAUTIONS FOR OPERATORS AND TECHNICIANS

- The use of the machine is forbidden by staff who are unauthorised and untrained in operation and people who are under the influence of substances that can alter reflexes (alcohol, medicine, drugs, etc.).
- **To avoid unpermitted use of the machine, the power supply must be interrupted, to do this remove the ignition key;**
- Do not use the machine in flammable areas or where there is danger of explosion;
- Do not collect burning material or other material that could cause a fire;
- Do not remove the safety devices and the guards when the machine is running;
- Start the machine from the driver's seat;
- Do not use the machine to clean objects;
- During the maintenance phase, avoid wearing loose or unbuttoned clothing;
- Do not proceed with maintenance phases when parts are in motion;
- Protect eyes and ears when using compressed air or water guns to clean the machine;
- To lift the machine, use devices suitable for the weight of the machine;
- Do not generate flames or sparks near the machine;
- Disconnect the battery cables before intervening on the electrical circuit;
- Avoid contact with battery acid, pay attention to hot parts, wait for them to cool before intervening;
- Unguarded machines must be protected from unintentional movements, use the parking brake;
- **Do not exceed gradients of 21 % in the direction of movement and gradients of 10% transverse to the direction of movement.**
- **Pay attention when changing direction and/or direction of travel, moderate speed on bends as there is a danger of tipping over.**



## RESPONSIBILITIES OF THE OPERATOR

- The operator must not work on wet floors;
- The operator is responsible for the day-to-day servicing of the machine;
- The operator must care for the machine and keep it in good operating condition;
- The operator must inform his or her superior or the technical department when scheduled maintenance is requested in the case of damage or breakage;
- The operator must not carry people, animals or objects on the machine;
- When moving the machine, observe the safety measures for circulation;
- The machine cannot be used for toxic-harmful materials;
- Never let people get close to the machine's sphere of action;
- Never leave the sweeper with the key and the emergency switch inserted;
- Engage the hand brake;
- If the machine malfunctions, have a look at the procedures shown in the various chapters;
- Never collect pieces of string, wire or anything else that could damage the brushes by winding around them;
- This machine must be used only in closed places;
- Don't use the machine to clean surfaces with gradients over indicated on it;

### UPDATING OF THE USER'S MANUAL

When large-scale modifications are made to the machine or new parts are installed, the updated documentation must be sent to the Dealer along with the purchased part or as an update of the manual.

### OBLIGATIONS OF THE EMPLOYER OR OWNER OF THE MACHINE

The employer or owner of the machine is responsible for giving the User's Manual to all the personnel who are going to have to use the machine.

The employer or owner of the machine also undertakes to update the manual with the documentation that the Manufacturer will send if modifications are made to the machine.

## DISPOSAL



All packaging is recyclable. The packaging should not be thrown away with domestic waste, but sent to the relevant collection centres.



### EXHAUSTED LEAD-ACID BATTERIES

Exhausted batteries are considered harmful toxic waste and therefore should be exclusively given to collection companies with specific authorisation (ascertain on hand-over).

### MATERIAL COLLECTED FROM THE MACHINE

The waste collected by the machine must be given to the relevant urban cleaning company since it is considered urban waste or similar. The machine cannot be used to collect toxic-harmful materials.

### SCRAPPING THE MACHINE

On scrapping, proceed with the correct disposal of the materials that make up the machine. It is compulsory to give the machine to authorised collection companies which will correctly dispose of oil, filters, plastic, metal, electric motors, electric boards, etc. in compliance with legislation in force. Decommissioned equipment contains precious recyclable materials and therefore should be given to the relevant collection centres. Please dispose of decommissioned equipment through differentiated collection systems.



### DISPOSAL OF ELECTRICAL EQUIPMENT AND ELECTRONICS



## TRANSPORT AND UNPACKING

The machine must be fixed to a pallet to make it easier to transport.

Our company packs the machine by removing the following components:

- Steering wheel
- Seat
- Side brush

**Before dismounting it, please mount the steering wheel and the seat.**

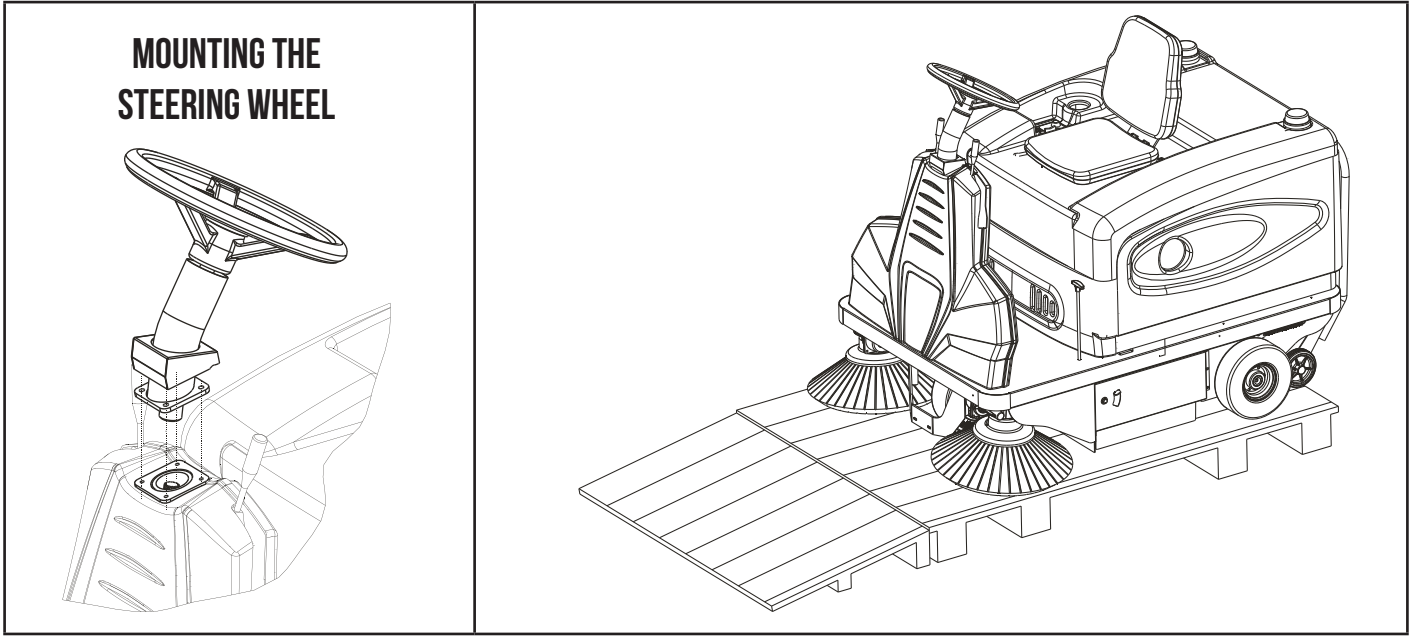

To unpack it, do the following:

- Connect a ramp to the pallet as shown in the figure;
- Remove the wedge locking the front wheel in place and any other fixing materials; it is not necessary to remove the wedges on the rear wheels;
- Bring the machine down the ramp;

The machine must be taken off the pallet by lifting it with a gantry crane or other suitable means providing that belts, ropes and chains connected to the machine in the openings indicated in the figure are used.

**DO NOT REMOVE THE MACHINE FROM THE PALLET WITH A FORKLIFT TRUCK THAT COULD DAMAGE IT.**



## HANDLING AND TRANSPORT

When the machine is moved from one place it is used in to another you are advised to:

- Not load it on the vehicle with a forklift truck in order not to damage it;
- Lock the machine in place with the parking brake;
- Fix it well to the vehicle using belts, ropes and chains, securing it in the points indicated in the figure;

# MACHINE DESCRIPTION

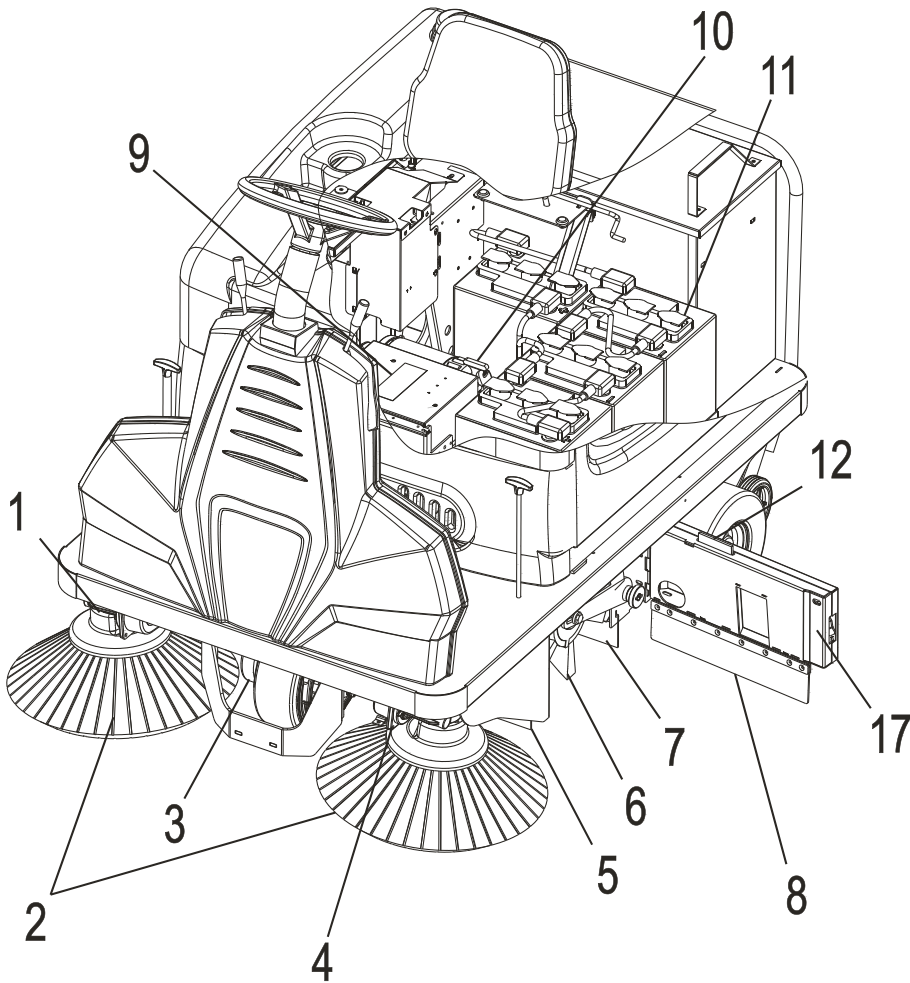

1. RIGHT SIDE BRUSH GEAR MOTOR
2. SIDE BRUSHES
3. DRIVE WHEEL
4. LEFT SIDE BRUSH GEAR MOTOR
5. FRONT RUBBER
6. MAIN BRUSH
7. REAR RUBBER
8. LEFT SIDE BRUSH RUBBER
9. ELECTRIC SYSTEM BOX
10. BATTERY CONNECTOR
11. BATTERY
12. MAIN BRUSH REPLACEMENT KEY
13. BAG FILTER
14. FAN
15. DIRT CONTAINER
16. RIGHT SIDE RUBBER
17. LEFT SIDE

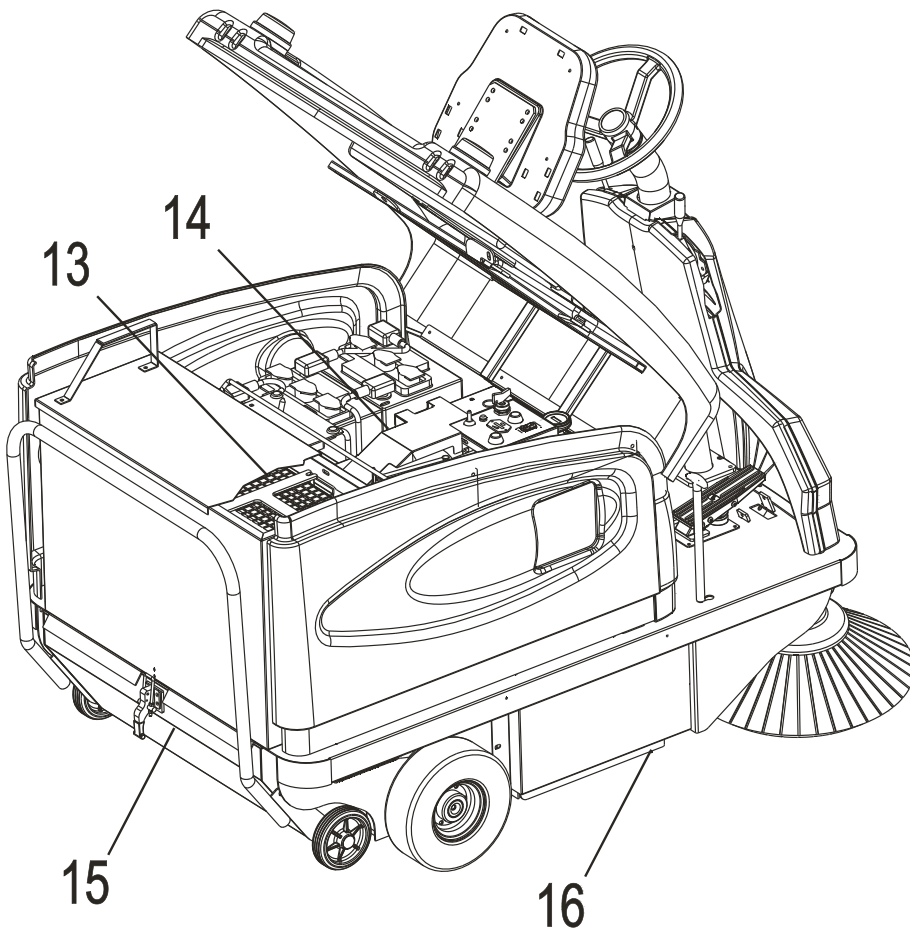

# PRIMARY FUNCTIONS AND CONTROLS

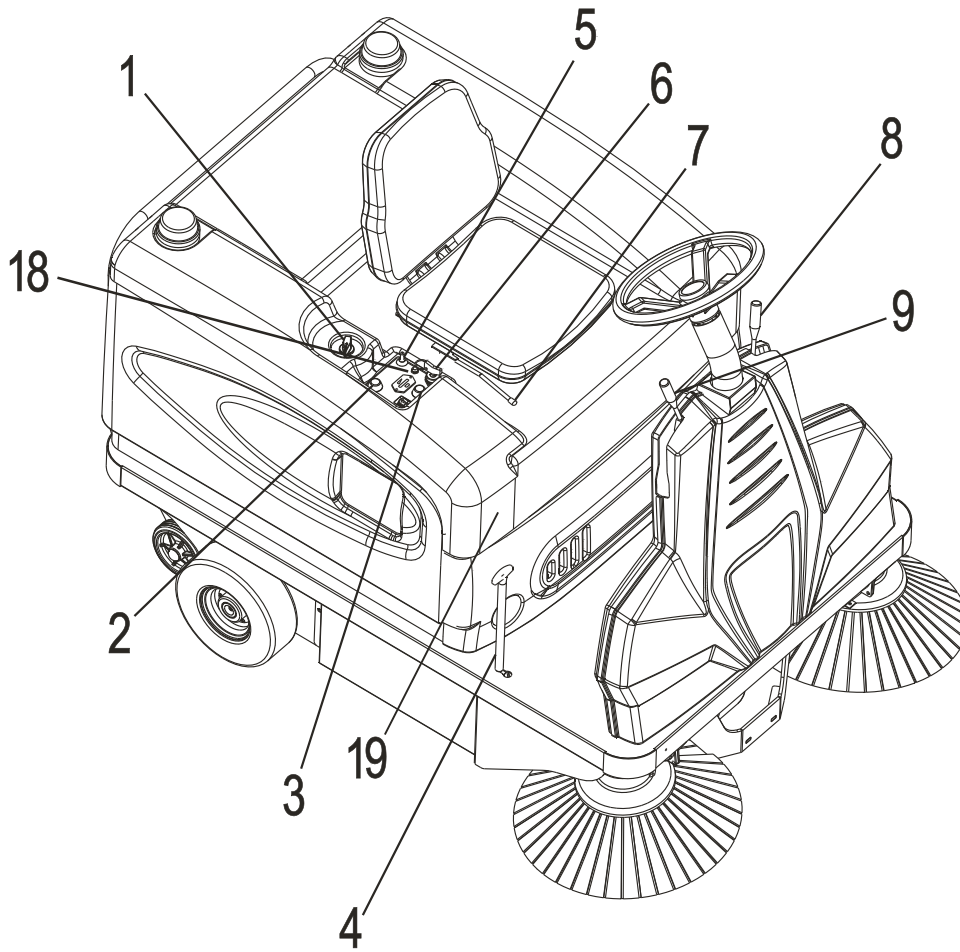

1. VACUUM CLOSURE CONTROL
2. FILTER SHAKER BUTTON
3. BEEPER
4. MAIN BRUSH CONTROL
5. BRUSH/VACUUM MOTOR SWITCH
6. IGNITION KEY
7. SEAT ADJUSTMENT LEVER
8. LEFT SIDE BRUSH LEVER
9. RIGHT SIDE BRUSH LEVER
10. BRAKE LOCK (PARKING BRAKE)
11. FORWARD PEDAL
12. DIRECTION OF MOVEMENT SWITCH
13. HOURMETER
14. BRAKE PEDAL
15. LEFT SIDE OPENING LEVER
16. OPENING FLAP CONTROL
17. DIRT CONTAINER OPENING LEVER
18. TRACTION BOARD OPERATION LIGHT
19. EMERGENCY LEVER

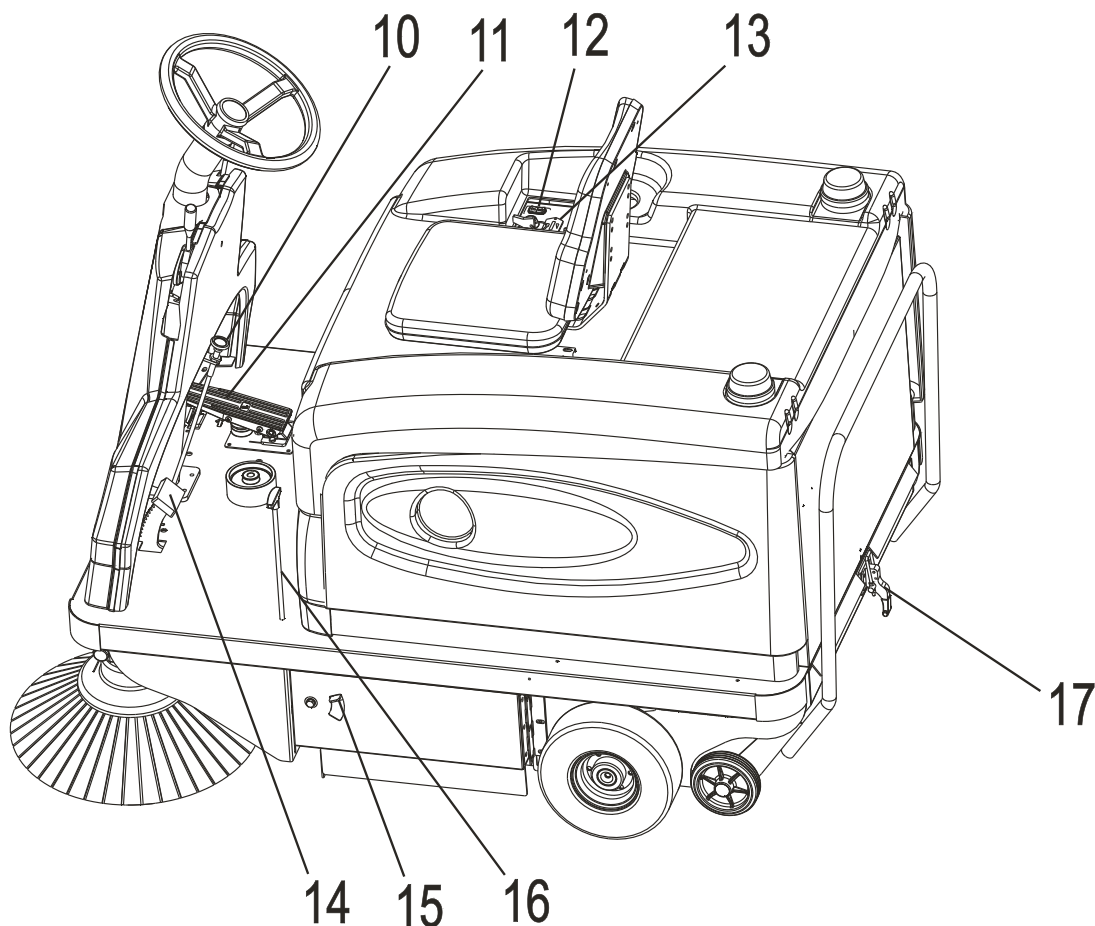



- 1  **VACUUM CLOSING CONTROL**  
If the lever is in forward position (DRY) the vacuum is on  
If the lever is in back position (WET) the vacuum is off
- 

- 2  **FILTER SHAKER BUTTON**  
Press this button for few seconds to enable the shaker filter
- 

- 3  **BEEPER**
- 

- 4  **MAIN BRUSH CONTROL**  
Lower the lever to engage and lower the main brush.  
To activate the brush, lift slowly the lever and push forward
- 

- 5  **BRUSH/VACUUM MOTOR SWITCH**  
POS. 1: Brush and vacuum motor start position  
POS. 0: Brush and vacuum motor stop position
- 

- 6  **IGNITION KEY**  
POS. 0: turn off the engine  
POS. 1: start the engine  
**WARNING: After turning off the machine by the key, wait until 3-4 seconds before starting it again, otherwise the electronic card will give a message of error (13 flashes)**
- 

- 7  **SEAT ADJUSTMENT LEVER**  
Pull the lever right to adjust the seat forward or back
- 

- 8  **LEFT SIDE BRUSH LEVER**
- 

- 9  **RIGHT SIDE BRUSH LEVER**

- 10  **BRAKE LOCK (PARKING BRAKE)**  
To activate the parking brake, press the pedal and push the locking brake knob.  
To release it, push slowly the brake pedal and push back the unlocking knob.
- 

- 11  **DIRECTION OF MOVEMENT CONTROL**  
By pressing the button forwards, forward movement is selected. By pressing the button backwards, reverse movement is selected.
- 

- 12 **FORWARD PEDAL**  
- FORWARD DRIVE: set the switch (point 11) to forward drive and then press the pedal;  
- REVERSE DRIVE: set the switch (point 11) to reverse drive and then press the pedal;  
Releasing the pedal applies braking to the machine (SERVICE BRAKE).  
Pedal travel progressively regulates the speed.
- 

- 13 **BATTERY CHARGE INDICATOR**  
When all the LEDs are green, this means the battery is charged.  
When the red LED comes on after about 20 seconds, the brush motors stop. Go to recharge position to recharge the battery.  
Important: unless otherwise indicated on the order, the indicator features a standard setting for lead-acid batteries.  
In case different batteries are fitted (GEL, AGM, etc.) the setting must be changed to avoid damaging the batteries (PAGE 16).
- 

- 14 **BRAKE PEDAL**  
Pressing the pedal, the emergency brake is engaged
- 

- 15 **LEFT SIDE OPENING LEVER**
- 

- 16  **FLAP OPENING CONTROL**  
Lift the lever to raise the flap to enable the light and big debris collection
- 

- 17 **DIRT CONTAINER OPENING LEVER**  
Release this lever to remove the dirt container to empty it
- 

- 18 **TRACTION BOARD OPERATION INDICATOR**
- 

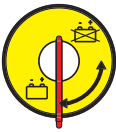
- 19  **EMERGENCY LEVER**  
This lever is used to halt the machine in case of emergency and to lock all of its functions.  
Turn the lever clockwise to reset the power.

# USING THE MACHINE

SWEEPERS MUST BE OPERATED BY PERSONNEL WHO ARE SUITABLY TRAINED AND AUTHORISED.  
THE SWEEPERS THAT ARE NOT IN FULL WORKING ORDER MUST BE REMOVED FROM SERVICE.

THE SEAT IS FITTED WITH DIPSWITCH THAT PREVENTS IT BEING MOVED FORWARD OR BACK IF THE OPERATOR IS NOT SITTING IN THE DRIVING SEAT.  
BEFORE STARTING WORK CHECK THE WORKING OF THE DIPSWITCH.

## OPERATION

- Connect the battery connector
- Sit in the driving seat
- Insert the key and turn it in pos.1
- Start up the brush motor
- Open the suction with the relevant lever if closed
- Lower the main brush
- Lower the side brushes
- Select the direction of movement
- Press the pedal for forward movement

## IMPORTANT ADVICE

- Slow down on bends
- Shake the filter often
- Do not sweep up ropes, string, wire or anything else that could become entangled
- Check the dust guard sealing and the rubber often
- Be careful of sidewalks and anything sticking out of the pavement
- If possible, unload the dirt from the dirt container into a container instead of onto the ground

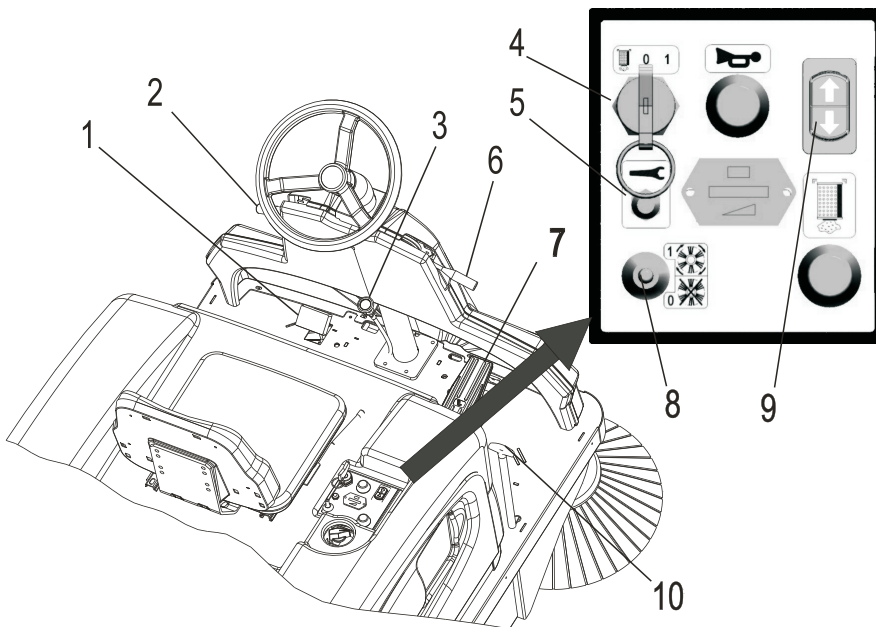

1. BRAKE PEDAL
2. LEFT SIDE BRUSH LEVER (OPTIONAL)
3. PARKING BRAKE CONTROL
4. KEY
5. TRACTION BOARD OPERATION INDICATOR
6. RIGHT SIDE BRUSH LEVER
7. FORWARD PEDAL
8. VACUUM/BRUSH SWITCH
9. FORWARD MOVEMENT SWITCH
10. MAIN BRUSH LEVER

## STARTING THE MACHINE

- Before starting the machine, make sure the main brush and the side brushes are raised from the ground (pos.2, pos.6, pos.10);
- Turn the key clockwise of a notch pos.4;
- Start the brush and vacuum motor by means of the switch pos.8;
- Lower the central brush pos.10 and/or the side brushes pos.2 and 6 to start them and press the pedal for machine forward movement;

## TRANSPORTING ONLY

- To simply transfer the machine, make sure the central brush pos.10 and/or the side brushes pos.2 and 6 are lifted;
- Move the switch pos.8 to position 0;
- Press the pedal pos.7 for machine forward movement;

## TURNING OFF THE MACHINE

- After completing work and/or transport operation, park the machine, and engage the parking brake by means of the pedal pos.1 and pull the knob pos.3. Lift all the brushes by means of the levers pos.2, pos.6, pos.10;
- Bring the switch pos.8 in position 0;
- Turn the key pos.4 in position 0;
- **WARNING: After turning off the machine by the key, wait until 3 -4 seconds before starting it again otherwise the electronic card will give a message of error (13 flashes).**

## RECHARGING BATTERY

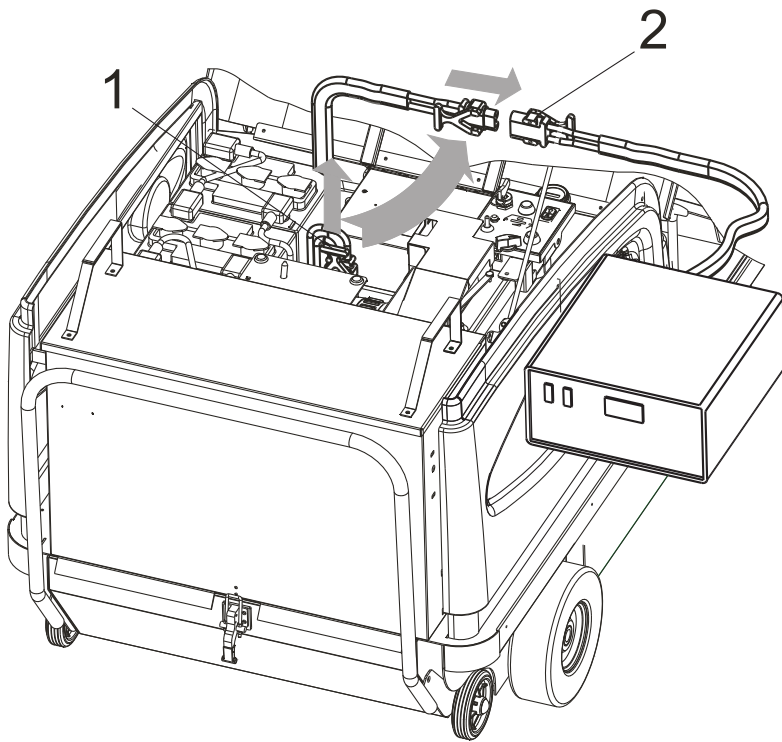

- Switch off the machine and engage the parking brake;
- After lifting the bonnet-seat, disconnect the connector pos. 1 from the machine and connect it to the battery charger pos. 2;
- Before charging the battery make sure you carefully follow the instructions in the battery charger manual provided with the machine;
- Charge the batteries with an intensity not above one twentieth of their capacity;
- **After charging, check the level of the electrolyte and if necessary top up with distilled water only;**
- Reconnect the battery connector and that of the machine to start the machine again;
- For further and more detailed recharging suggestions, please read the battery operation sheet;
- The battery should only be recharged in well-ventilated environments;
- The gas released during the charging process can cause explosions if it comes into contact with flames or sparks;
- Battery acid should never come into contact with the eyes, skin or clothes, make sure goggles, gloves and appropriate clothing are worn;
- If it comes into contact with the eyes or skin, wash immediately with abundant water;
- Do not place metal objects on the batteries;
- Do not fill the batteries with sulphuric acid or other products;

## REPLACING THE FUSES



1. ELECTRIC PLAN BOX
2. SCREW
3. SPARE FUSE 60A
4. GENERAL FUSE 15A
5. TRACTION FUSE 60A
6. BRUSH/VACUUM MOTOR FUSE 70A
7. SPACER
8. INTERMITTENCE
9. SHAKER FUSE 15A
10. BRUSH MOTOR CUT-OUT SWITCH 60A:

WHEN THE ABSORPTION OF THE BRUSH MOTOR RISES ABOVE ITS LIMIT, THE THERMISTOR ACTIVATES AND MOVES INTO "OFF" POSITION. ONCE MOTOR TEMPERATURE GETS BACK TO STANDARD LEVELS (THIS USUALLY OCCURS A FEW MINUTES AFTER THE MOTOR IS SWITCHED OFF) YOU CAN RESET THE THERMISTOR BY TURNING THE LEVER TO "ON" SETTING. SHOULD THE SWITCH BE ACTIVE AGAIN, CHECK THE POSSIBLE REASONS REFERRING TO THE "TROUBLE-SHOOTING CHART".

- Lift the hood and block it by the apposite bar
- Remove the battery connector.
- To access the fuses inside the power system box, loosen the screws pos.2 and take off the cover. If necessary, loosen the spacer pos.7 and remove the intermittence pos.8;
- Find out the faulty fuse:
  - 4) GENERAL FUSE 15A (inside the machine near the engine oil bar)
  - 5) 60A DRIVE FUSE (inside the power system box)
  - 6) 70A BRUSH/VACUUM MOTOR FUSE (inside the power system box)
  - 9) SHAKER FUSE 15A (on the right side of the machine, under the control panel)
- 2 x 60A spare fuses fastened outside the power system box pos.3
- Remount everything

NOTE! **DON'T CHANGE THE AMPS. VALUE OF THE FUSE**

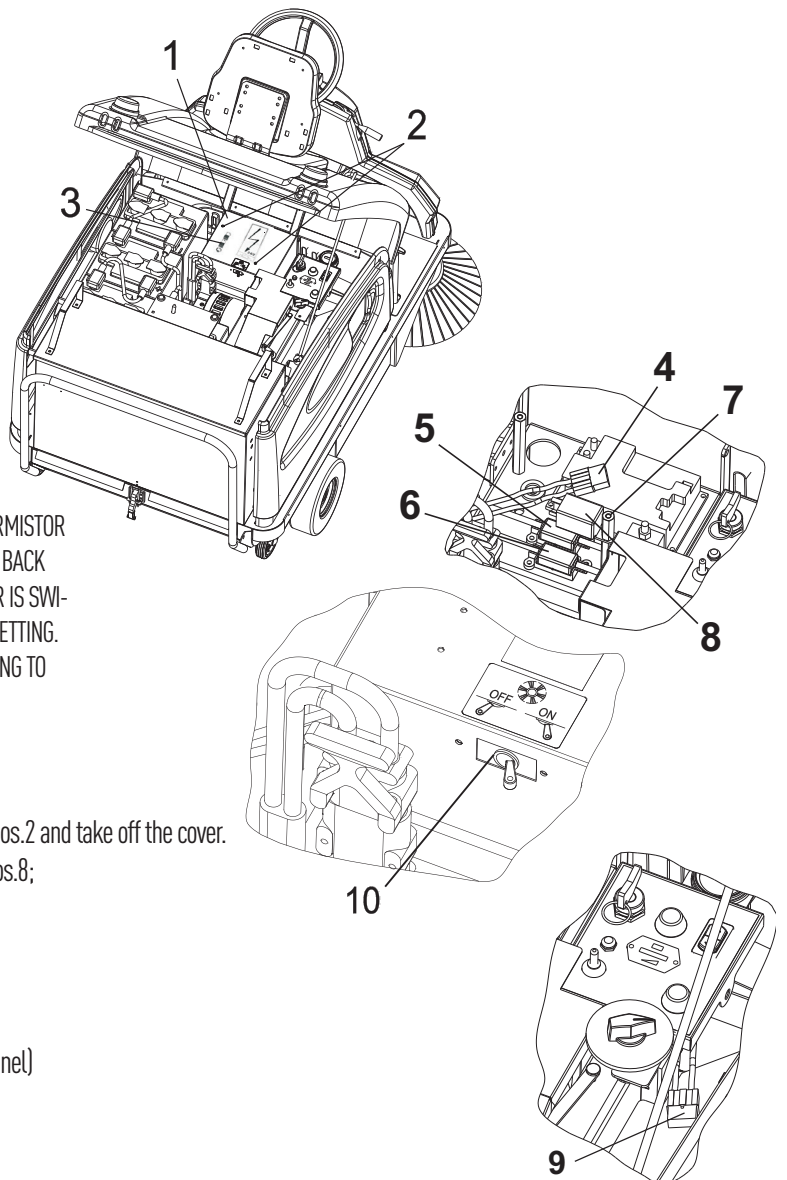

## BATTERY CABLE LENGTH

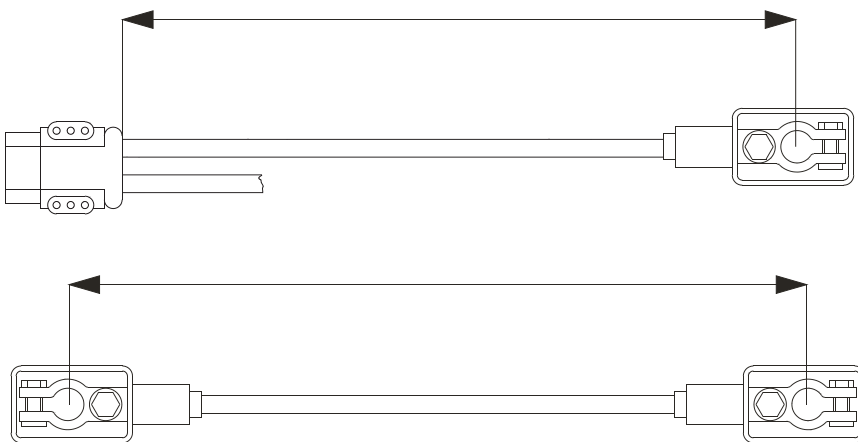
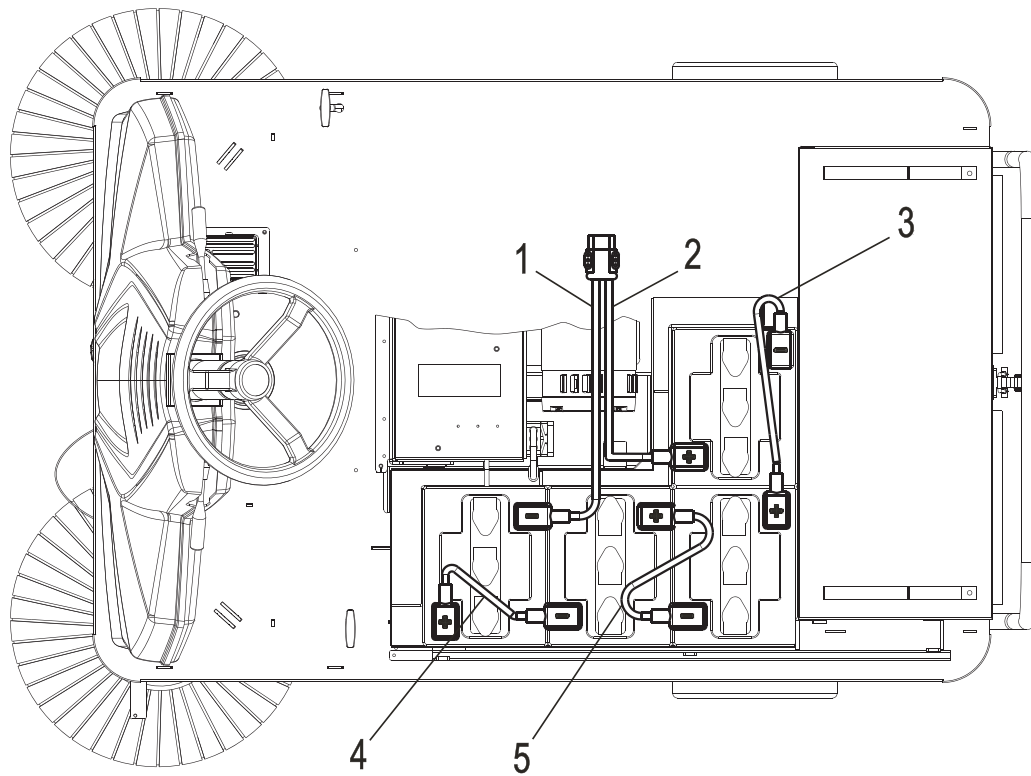

N°	COLOUR	Ømm <sup>2</sup>	LENGHT
1	BLACK	16	700 mm
2	RED	16	700 mm
3	RED	16	490 mm
4	RED	16	335 mm
5	RED	16	305 mm

## SETTING THE CHARGE INDICATOR

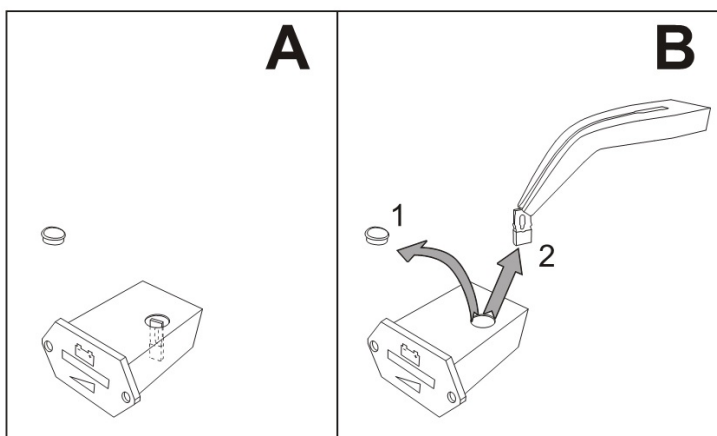

With the jumper inserted, the charge indicator is set for lead acid batteries (FIG.A). Without the jumper, the charge indicator is set for gel/agm batteries (FIG.B). If the indicator is set for gel/agm batteries and you want to install lead acid batteries, please contact the company for the jumper.

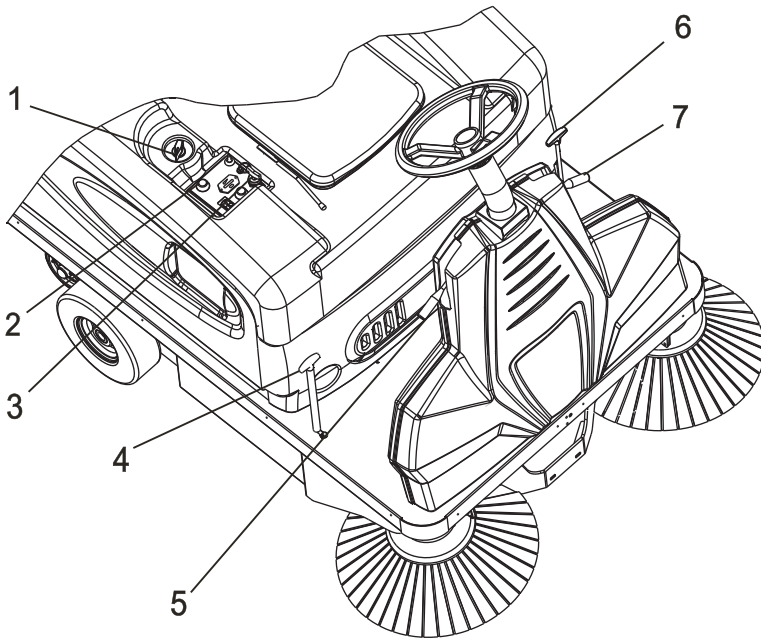

1. VACUUM CLOSING KNOB
2. SHAKER FILTER BUTTON
3. KEY
4. MAIN BRUSH LEVER
5. RIGHT SIDE BRUSH LEVER
6. FRONT FLAP LEVER
7. LEFT SIDE BRUSH LEVER

### VACUUM CLOSING CONTROL

SHOULD YOU GO ACROSS A WET FLOOR OR A COURTYARD WITH PUDDLES, YOU MUST CLOSE THE VACUUM, SO AS TO PROTECT THE POLYESTER FILTER.

- With the lever pos.1 forward (DRY), the vacuum is on;
- Turn the lever back (WET), the vacuum is off;

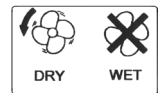

### FILTER SHAKER CONTROL

- Press the key downwards and turn it anti-clockwise;
- Press the button for 5-10 sec and then release it.
- Repeat the operation several times.

N.B.: SWEEPER CLEANING QUALITY IS CLOSELY LINKED TO FILTER CLEANING. PLEASE SHAKE IT OFTEN, IN PARTICULAR WHEN THE FLOOR IS VERY DUSTY.

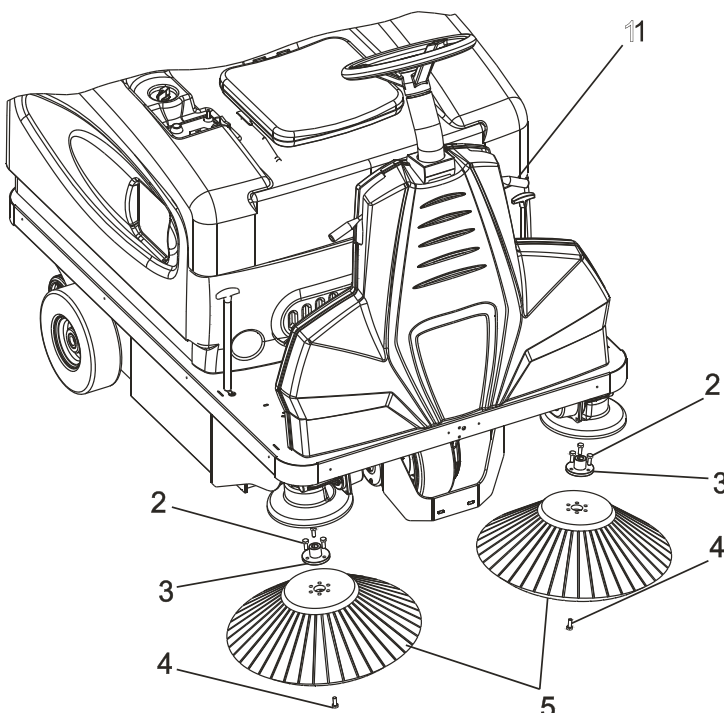
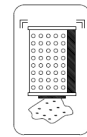

1. RIGHT AND LEFT SIDE BRUSH LEVERS
2. FLANGE SCREW
3. FLANGE
4. MAIN SCREW
5. RIGHT AND LEFT SIDE BRUSH

### SIDE BRUSH CONTROL

Before starting up the brushes, make sure that there are no ropes, strings, wire or anything else wound around the brushes.

The side brush rises and is lowered by working the lever in pos.1:

- when the lever is vertical, the brush is down and is turning.
- when the lever is down, the brush is raised and still.

### REPLACING THE SIDE BRUSH



- Raise the brushes lever pos.1
- Undo the screw in pos.4 using a normal key from 17
- Remove the brush pos.5
- Dismantle the flange of the old brush and refit it on the new one pos.3
- Put everything back together again.

1. DIRT CONTAINER
2. DIRT CONTAINER WITH REFUSE BOXES KIT (OPTIONAL)

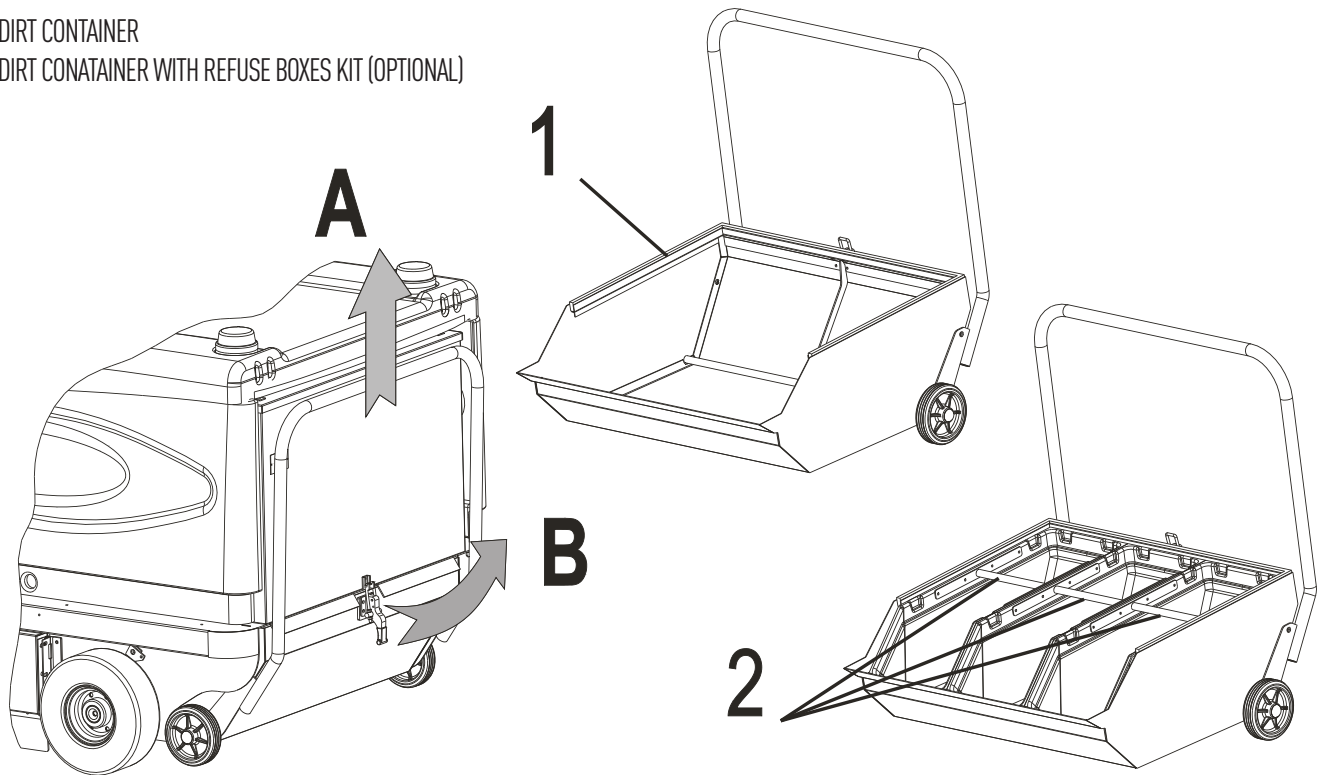

## EMPTYING THE DIRT CONTAINER



After using the machine in dusty areas or with many debris, it is necessary to empty the dirt container.

To empty it, please proceed as follows:

- Shake often the filter;
- Turn off the engine and insert the parking brake;
- Hold the dirt container using the handle (A);
- Unhook the container locking hook turning the lever in the direction shown by the arrow (B);
- Empty the dirt container in the apposite area pos.1;
- (OPTIONAL) If the machine is equipped with refuse boxes kit, please empty it pos.2;
- After emptying the dirt container, put it in the machine and block it by the hook (B);

### DX

### SX

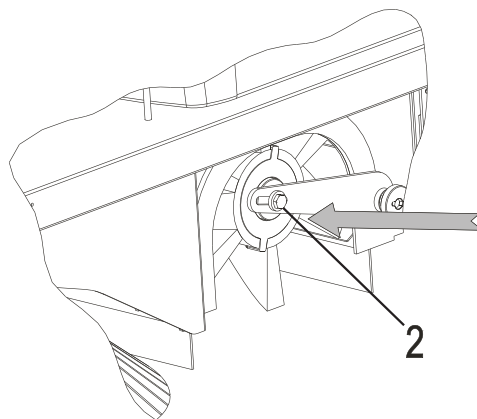
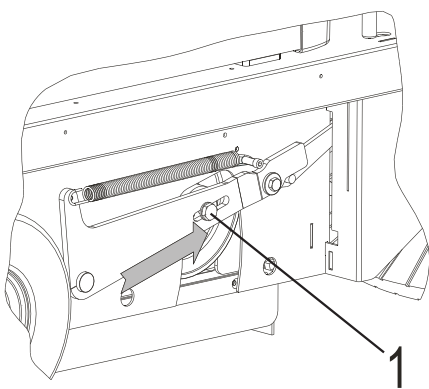

## ADJUSTING THE MAIN BRUSH



- Turn off the engine and insert the parking brake.
- Raise the main brush lever
- Open the left side door and remove the right side.
- Unloose the fixing screws of the main brush hubs
- If the brush is worn, move the hubs in the direction of the arrow (forward). If you replace the brush with a new one, bring the hubs in the opposite direction of the brush (back).
- After adjusting the main brus, screw completely the hubs' screws; remount the right side and close the left door.

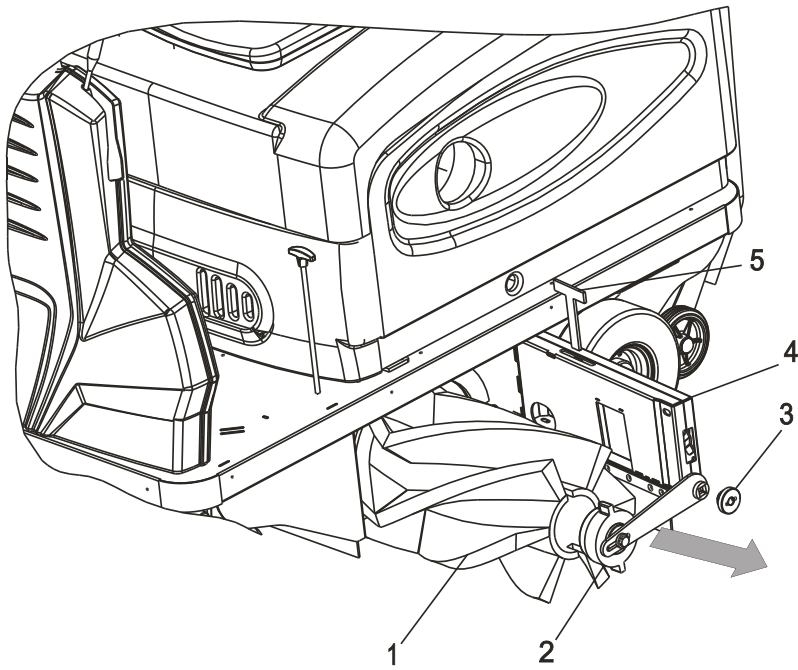

1. MAIN BRUSH
2. MAIN BRUSH LEFT SUPPORT
3. LOCKING BUSH
4. LEFT SIDE DOOR
5. KEY
6. MAIN BRUSH LEVER

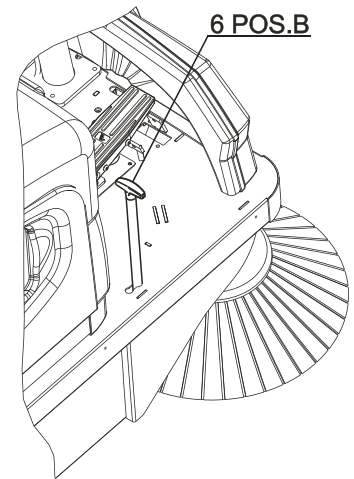
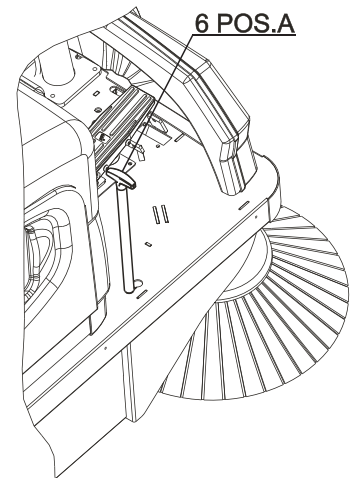

## MAIN BRUSH CONTROL

Before starting up the brushes, make sure that there are no ropes, strings or wire wound around the brushes

The side brush rises and is lowered by working the lever in pos. 6:

- when the lever is in pos A, the brush is raised and still.
- when the lever is pos B, the brush is down and is turning.

## REPLACING THE MAIN BRUSH



- Turn the engine off and insert the parking brake
- Lower the main brush lever
- Open the left side door pos.4 and remove the key pos.5
- Unscrew the ring nut pos.3 using the key pos.5
- Extract the support pos.2 and the brush pos.1 by pulling in the direction of the arrow
- Replace the brush. When refitting it, be very careful that the cusp is set the right way
- Refit everything and bring the main brush lever to the raised position

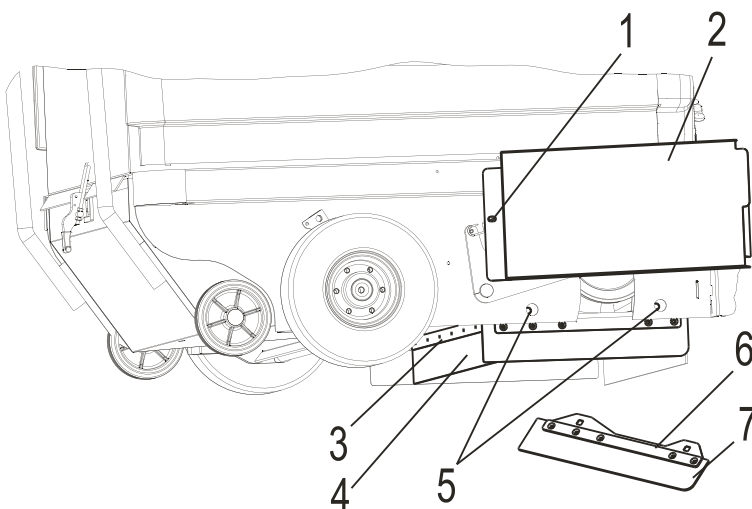

1. RIGHT PANEL FIXING SCREWS
2. RIGHT PANEL
3. REAR RUBBER FLAP FIXING METAL SHEET
4. REAR RUBBER FLAP
5. RIGHT RUBBER FLAP FRAME FIXING SCREWS
6. RIGHT RUBBER FLAP FIXING METAL SHEET
7. RIGHT RUBBER FLAP

## REPLACING THE RIGHT SIDE RUBBER FLAP



- Remove the right side panel pos.2 after removing the screw pos.1
- Loosen the fixing screws of the right dust guard assembly pos.5
- Unscrew the 5 fixing screws of the right metal sheet pos.6 and replace the right rubber flap pos.7
- Replace the rubber
- Put everything back together again

## REPLACING THE REAR SIDE RUBBER FLAP



- Remove the dirt container and the main brush
- Remove the fixing metal sheet of the rear rubber flap pos.3
- Replace the rear rubber flap pos.4
- Put everything back together again

1. RIGHT RUBBER FLAP FIXING METAL SHEET
2. RIGHT RUBBER FLAP
3. FIXING SCREW
4. FIXING LEVER NUT
5. COMPLETE FLAP
6. FRONT RUBBER FLAP FIXING METAL SHEET
7. FRONT RUBBER

## REPLACING THE LEFT SIDE RUBBER FLAP

- Turn off the engine and insert the parking brake.
- Open the left side door
- Unscrew the 8 fixing screws of the left metal sheet pos.1
- Replace the left side rubber flap pos.2.
- Put everything back together again



## REPLACING THE FRONT RUBBER FLAP

- Turn off the engine and insert the parking brake.
- Open the left side door
- Remove the flap fixing screw pos.3 and the nut that blocks the lever pos.4
- Remove the complete flap pos.5 and after removing the metal sheer pos.6, replace the front rubber flap pos.7
- Put everything back together again

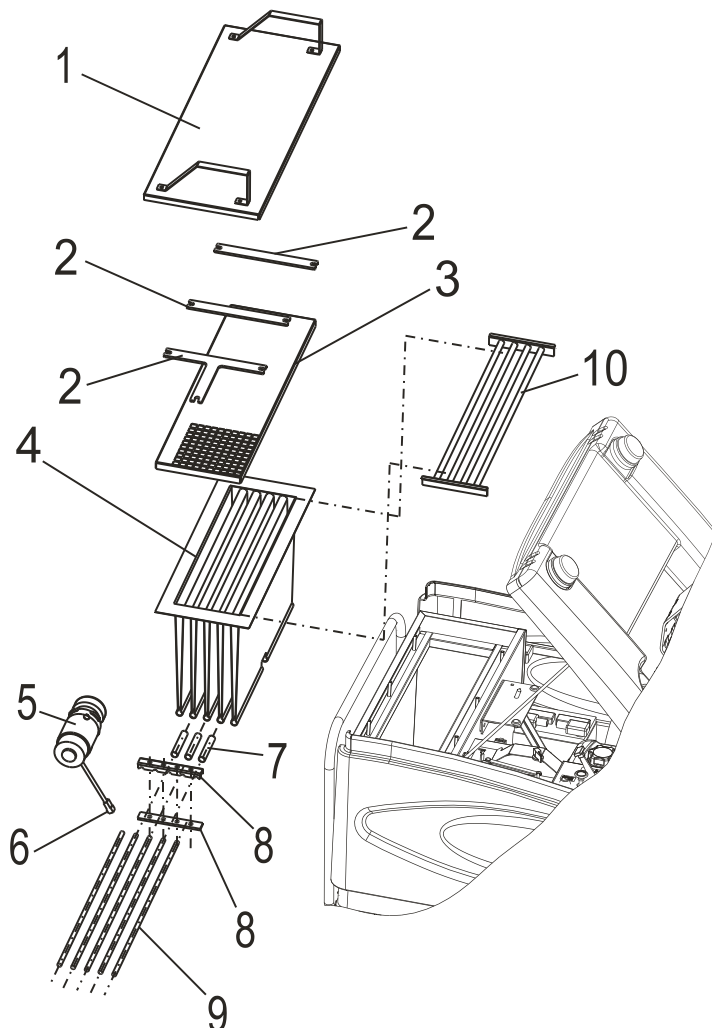
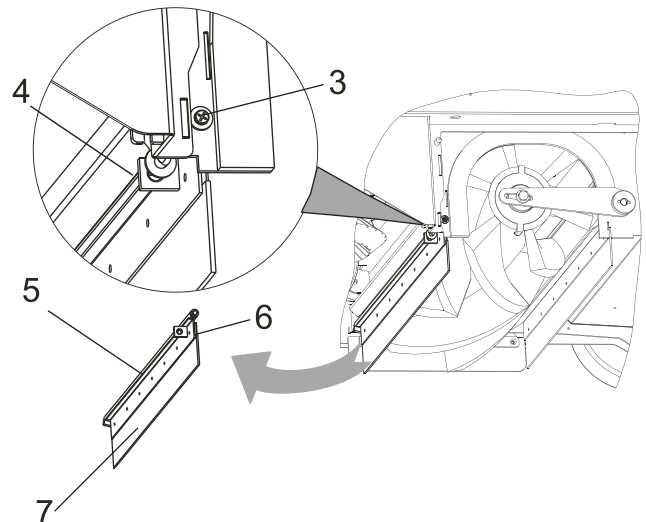
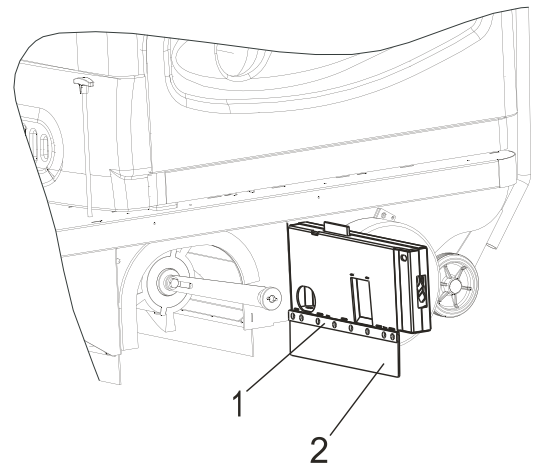

1. FILTER COVER
2. LOCKING BRACKET
3. LOCKING FILTER COVER
4. BAG FILTER
5. SHAKER
6. CONNECTOR
7. SPACERS
8. SHAKER LOCKING PLATES ON RODS
9. FILTER SUPPORT RODS
10. FILTER SUPPORT

## REPLACING THE FILTER



- Carefully shake the filter
- Remove the key
- Raise the hood and lock it by the bar
- Remove the filter cover pos.1
- Remove the plates pos.2 and the blocking mesh pos.3
- Raise the filter and disconnect the connector pos.6
- Position the filter on a table
- Undo the locking screws of the filter shaker and remove the filter shaker pos.5
- Remove the remaining screws and undo the two plates, pos.8
- Remove the bars pos.9 and the spacers pos.7 from the filter
- Remove the filter support pos.10
- Replace the filter pos.4
- Refit all the parts by following the above phases in reverse order
- Refit everything being carefully to insert connector pos.6 correctly

# DIMENSIONAL DRAWINGS

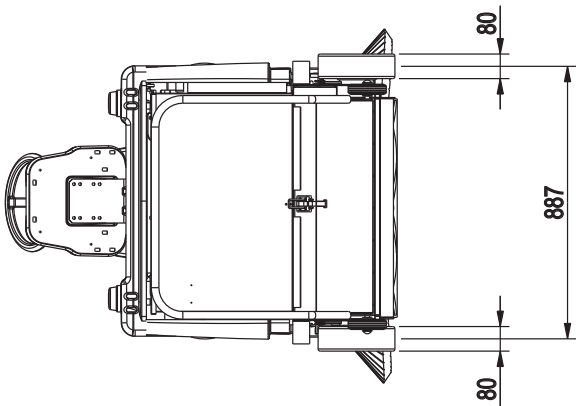
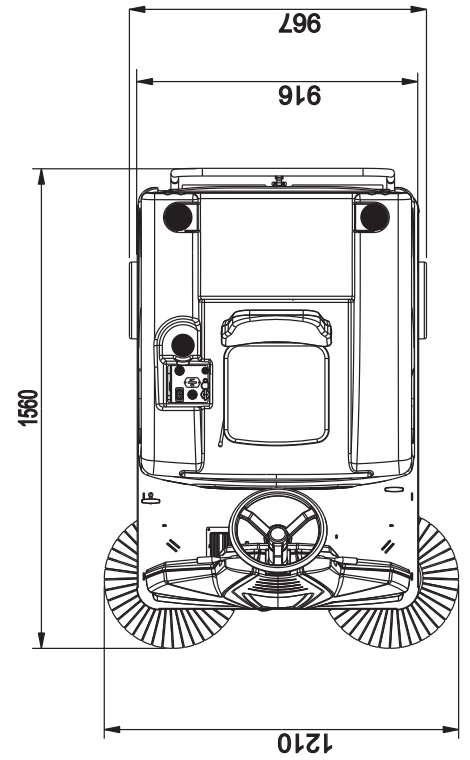
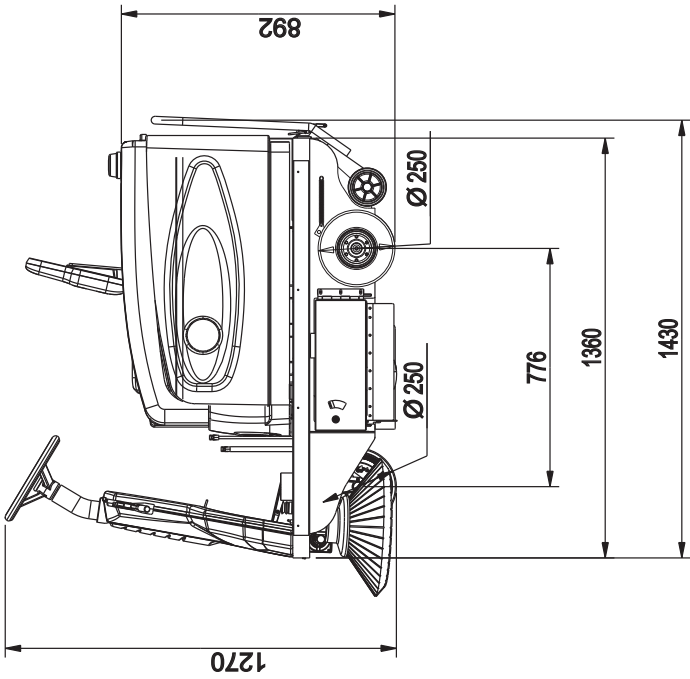
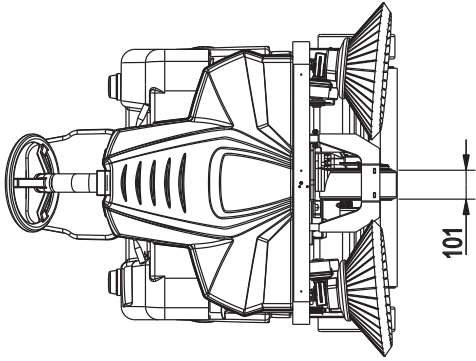

# TECHNICAL CHART

<b>MAIN SPECIFICATION</b>	Cleaning path with side brush	1.200 mm
	Hourly performance with 2 side brushes	7.865 m <sup>2</sup> /h
	Forward speed	0 - 6,6 km/h
	Dirt container capacity	85 L
	Maximum gradient	15 - 18 %
	Turning radius	1.050 mm
<b>DIMENSIONS AND WEIGHT</b>	Dimensions with 2 side brushes	1.560 x 1.200 x 1.250 mm
	Dimensions with side brush	1.560 x 1.070 x 1.250 mm
	Dimensions without side brush	1.430 x 967 x 1.250 mm
	Weight	305 kg
	Weight with type A batteries	435,4 kg
	Weight with type B batteries	429 kg
	Packaging dimensions	1.560 x 1.100 x 1.100 mm
	Packaging weight	40 kg
	Packaging volume	1,89 m <sup>3</sup>
<b>BRUSHES</b>	Main brush dimensions	700 x Ø 285 mm
	Side brush diameter	500 mm
<b>TRACTION SYSTEM</b>	Traction type	Electronic
	Traction motor	24V - 850 W
	Power absorption (machine loaded)	20 - 25 A
<b>PRIMARY ELECTRIC MOTOR</b>	Primary motor	24V - 1200 W
	Power absorption (machine loaded)	48 - 53 A

<b>TYPE A BATTERIES</b>	Type	4 lead acid batteries 6V 240A C20 - 180A C5
	Dimensions ea.	242 x 190 x 285 mm
	Autonomy (theoretical)	3 h
<b>TYPE B BATTERIES</b>	Type	4 gel batteries 6V 180A C5
	Dimensions ea.	242 x 190 x 285 mm
	Autonomy (theoretical)	2 h 45 min
<b>FILTER SYSTEM</b>	Filter type	Filtro MultiPocket® classe L
	Total surface area	4 m <sup>2</sup>
<b>WHEELS</b>	Type of wheels	Full rubber, non-marking
	Front wheel	1, Ø 250 x 101 mm
	Rear wheels	2, Ø 250 x 80 mm
	Brakes	Drum brakes on rear wheels
<b>SOUND LEVEL (MEASURED ACCORDING TO ISO 11201)</b>	Noise emission value LpA	74 dB (A)
	Uncertainty KpA	2.4 dB (A)
<b>VIBRATION LEVEL</b>	Whole-body vibration level aW	1,61 m/s <sup>2</sup>
	Uncertainty K	0,64 m/s <sup>2</sup>
<b>TEMPERATURE RATING</b>	Storage temperature	-20 / +50 °C
	Operating temperature	-20 / +50 °C

# SERVICE AND MAINTENANCE RECORDS

1°

## SERVICE AND MAINTENANCE RECORD

**TO 50 HOURS**

**DATE**

DAY	MONTH	YEAR	WORKING HOURS

### BRUSH MOTOR

- Clean the outside of the motor using compressed air, above all the slats located at the rear
- Clean above the carbons and manifold

### TRACTION MOTOR

- Clean the outside of the motor using compressed air, above all the top part where the carbons and manifold are located

### MACHINE

- Check the liquid level in the battery
- Check the charge condition of each element
- Check the wear rate of brushes
- Check the rubber flaps wear
- Check the hopper gaskets wear
- Check the dust filters efficiency
- Check the tension of all belts
- Check the functioning of all instruments and levers
- Check the good functioning of the braking system
- Check the machine in all its functions

**THE SERVICE WAS CARRIED OUT ON:**

**NAME:**

**SURNAME:**

**SIGNATURE:**

**STAMP OF DEALER WHO CARRIED OUT SERVICE**

**NOTES**

2°

## SERVICE AND MAINTENANCE RECORD

**TO 100 HOURS**

**DATE**

DAY	MONTH	YEAR	WORKING HOURS

### BRUSH MOTOR

- Clean the outside of the motor using compressed air, above all the slats located at the rear
- Clean above the carbons and manifold

### TRACTION MOTOR

- Clean the outside of the motor using compressed air, above all the top part where the carbons and manifold are located

### MACHINE

- Check the liquid level in the battery
- Check the charge condition of each element
- Check the wear rate of brushes
- Check the rubber flaps wear
- Check the hopper gaskets wear
- Check the dust filters efficiency
- Check the tension of all belts
- Check the functioning of all instruments and levers
- Check the good functioning of the braking system
- Check the machine in all its functions

**THE SERVICE WAS CARRIED OUT ON:**

**NAME:**

**SURNAME:**

**SIGNATURE:**

**STAMP OF DEALER WHO CARRIED OUT SERVICE**

**NOTES**

**3°**

## SERVICE AND MAINTENANCE RECORD

**TO 200 HOURS**

**DATE**

DAY	MONTH	YEAR	WORKING HOURS

### BRUSH MOTOR

- Clean the outside of the motor using compressed air, above all the slats located at the rear
- Clean above the carbons and manifold

### TRACTION MOTOR

- Clean the outside of the motor using compressed air, above all the top part where the carbons and manifold are located

### MACHINE

- Check the liquid level in the battery
- Check the charge condition of each element
- Check the wear rate of brushes
- Check the rubber flaps wear
- Check the hopper gaskets wear
- Check the dust filters efficiency
- Check the tension of all belts
- Check the functioning of all instruments and levers
- Check the good functioning of the braking system
- Check the machine in all its functions

**THE SERVICE WAS CARRIED OUT ON:**

**NAME:**

**SURNAME:**

**SIGNATURE:**

**STAMP OF DEALER WHO CARRIED OUT SERVICE**

**NOTES**

**4°**

## SERVICE AND MAINTENANCE RECORD

**TO 300 HOURS**

**DATE**

DAY	MONTH	YEAR	WORKING HOURS

### BRUSH MOTOR

- Clean the outside of the motor using compressed air, above all the slats located at the rear
- Clean above the carbons and manifold

### TRACTION MOTOR

- Clean the outside of the motor using compressed air, above all the top part where the carbons and manifold are located

### MACHINE

- Check the liquid level in the battery
- Check the charge condition of each element
- Check the wear rate of brushes
- Check the rubber flaps wear
- Check the hopper gaskets wear
- Check the dust filters efficiency
- Check the tension of all belts
- Check the functioning of all instruments and levers
- Check the good functioning of the braking system
- Check the machine in all its functions

**THE SERVICE WAS CARRIED OUT ON:**

**NAME:**

**SURNAME:**

**SIGNATURE:**

**STAMP OF DEALER WHO CARRIED OUT SERVICE**

**NOTES**

**5°**

## SERVICE AND MAINTENANCE RECORD

**TO 400 HOURS**

**DATE**

DAY	MONTH	YEAR	WORKING HOURS

### BRUSH MOTOR

- Clean the outside of the motor using compressed air, above all the slats located at the rear
- Clean above the carbons and manifold

### TRACTION MOTOR

- Clean the outside of the motor using compressed air, above all the top part where the carbons and manifold are located

### MACHINE

- Check the liquid level in the battery
- Check the charge condition of each element
- Check the wear rate of brushes
- Check the rubber flaps wear
- Check the hopper gaskets wear
- Check the dust filters efficiency
- Check the tension of all belts
- Check the functioning of all instruments and levers
- Check the good functioning of the braking system
- Check the machine in all its functions

**THE SERVICE WAS CARRIED OUT ON:**

**NAME:**

**SURNAME:**

**SIGNATURE:**

**STAMP OF DEALER WHO CARRIED OUT SERVICE**

**NOTES**

<b>UP TO 500 HOURS AS FOR 50 HOURS</b>	<b>DATE</b>	<b>DAY</b>	<b>MONTH</b>	<b>YEAR</b>	<b>WORK. HOURS</b>
THE SERVICE WAS CARRIED OUT ON: NAME: SURNAME: SIGNATURE:		STAMP OF DEALER WHO CARRIED OUT SERVICE			

<b>UP TO 600 HOURS AS FOR 100 HOURS</b>	<b>DATE</b>	<b>DAY</b>	<b>MONTH</b>	<b>YEAR</b>	<b>WORK. HOURS</b>
THE SERVICE WAS CARRIED OUT ON: NAME: SURNAME: SIGNATURE:		STAMP OF DEALER WHO CARRIED OUT SERVICE			

<b>UP TO 700 HOURS AS FOR 200 HOURS</b>	<b>DATE</b>	<b>DAY</b>	<b>MONTH</b>	<b>YEAR</b>	<b>WORK. HOURS</b>
THE SERVICE WAS CARRIED OUT ON: NAME: SURNAME: SIGNATURE:		STAMP OF DEALER WHO CARRIED OUT SERVICE			

<b>UP TO 800 HOURS AS FOR 300 HOURS</b>	<b>DATE</b>	<b>DAY</b>	<b>MONTH</b>	<b>YEAR</b>	<b>WORK. HOURS</b>
THE SERVICE WAS CARRIED OUT ON: NAME: SURNAME: SIGNATURE:		STAMP OF DEALER WHO CARRIED OUT SERVICE			

<b>UP TO 900 HOURS AS FOR 400 HOURS</b>	<b>DATE</b>	<b>DAY</b>	<b>MONTH</b>	<b>YEAR</b>	<b>WORK. HOURS</b>
THE SERVICE WAS CARRIED OUT ON: NAME: SURNAME: SIGNATURE:		STAMP OF DEALER WHO CARRIED OUT SERVICE			

<b>UP TO 1000 HOURS AS FOR 500 HOURS</b>	<b>DATE</b>	<b>DAY</b>	<b>MONTH</b>	<b>YEAR</b>	<b>WORK. HOURS</b>
THE SERVICE WAS CARRIED OUT ON: NAME: SURNAME: SIGNATURE:		STAMP OF DEALER WHO CARRIED OUT SERVICE			

<b>NOTES</b>
--------------

# TROUBLE-SHOOTING CHART

## WARNING!

ANY TYPE OF SERVICE OPERATION OR TEST, WITH THE EXCEPTION OF THOSE SHOWN IN THE ENGINE'S MANUAL OR THE BATTERY'S MANUAL, MUST BE CARRIED OUT BY AUTHORIZED SERVICE CENTRES ONLY.

BEFORE ANY INTERVENTIONS CHECK THE CORRECT VOLTAGE OF THE BATTERY: 24V		
PROBLEM	CAUSE	SOLUTION
With key on, warning lights don't work	Starting battery is flat	Charge the battery
	Fuse is blown	Replace it
With the key inserted, the drive wheel fails to turn	Operator not seated	Sit down
	Drive wheel faulty or blocked	Repair or replace it
	Red indicator light flashing on panel	Based on the number of flashes, check the fault on the table below

## TRACTION BOARD FORWARD MOVEMENT: INDICATOR LIGHT FLASHING DIAGNOSTICS UP TO FRAME 120112580519

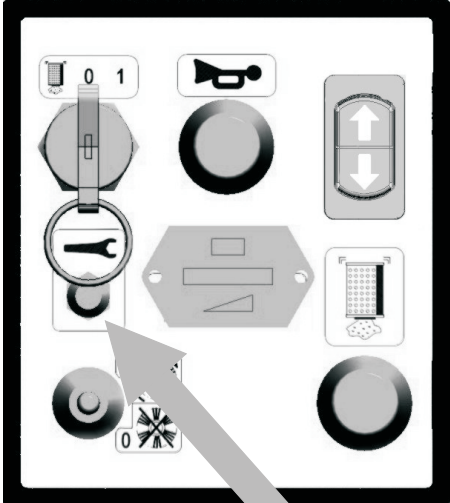
	OFF: NO ERROR, NORMAL CONDITION	
	1 FLASH: forward movement micro on at switch-on	<ul style="list-style-type: none"> <li>• Move the pedal to zero position</li> <li>• Make sure the pedal returns precisely to zero</li> </ul>
	2 FLASHES: reverse movement micro on at switch-on	<ul style="list-style-type: none"> <li>• Check the microswitch on the pedal</li> </ul>
	3 FLASHES: interruption of potentiometer signal	Check the potentiometer cables
	4 FLASHES: potentiometer not idle at switch-on	<ul style="list-style-type: none"> <li>• Move the pedal to zero position</li> <li>• Make sure the control returns precisely to zero</li> <li>• Check the potentiometer on the forward movement pedal</li> </ul>
	5 FLASHES: cutout tripped	Wait a few minutes before starting and check the drive wheel input
	6 FLASHES: - Power fuse damaged - Power stage damaged	<ul style="list-style-type: none"> <li>• Make sure the 60A power fuse from the battery + to the drive unit is OK and that the battery and motor cables are correctly connected</li> <li>• Replace the traction board</li> </ul>
	7 FLASHES: overcurrent	The cables from the battery to the traction board or from the traction board to the motor are loose, oxidized or not correctly connected. Check the cables
	8 FLASHES: power fuse or inside relay damaged	Make sure the 60A power fuse from the battery + to the drive unit is OK and that the battery and motor cables are correctly connected. If the problem continues, replace the traction board.
	9 FLASHES: undervoltage	Battery voltage below 19V.
	10 FLASHES: overvoltage	Battery voltage above 45V.
	11 FLASHES: amperometric cut-off for the traction motor	Working above max rated current of 35A. The cutout time depends on the current value achieved, above the rated value; e.g.: (at 90 A: time 60")
	13 FLASHES: temporary power supply interruption  The traction board power supply could drop down below 19V, with batteries almost discharged, when the main brush gets activated for example	<b>Attention! If 13 flashes appear, the operator should first ensure that at least 3-4 seconds have passed between turning off the machine (key in position 0) and turning on the machine (key in position 1). This is the time required for the traction electronic card to activate. Otherwise 13 flashes are generated.</b> If the problem persists it could be a bad electrical contact issue: check that in the ignition switch, fuses and the 16 poles connector of the chopper there isn't any intermittent contact. If the problem persists again replace the chopper. Charge the batteries and repeat the test with machine running and main brush activated.
	14 FLASHES: data reading failure	Remove the key and move the forward movement control to idle. If the problem continues, replace the traction board.

# TRACTION BOARD FORWARD MOVEMENT: INDICATOR LIGHT FLASHING DIAGNOSTICS

## FROM FRAME 120112590519

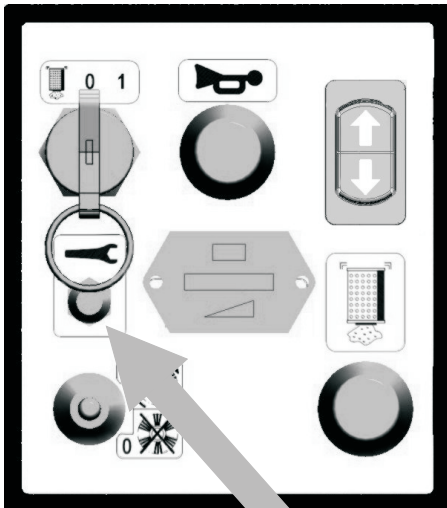

Example of count flashes:

••\_•••\_••\_•••\_••\_•••\_etc.= 2+3 flashes

### ALWAYS ON: NO ERROR, NORMAL CONDITION

1+2 FLASHES: overcurrent	<ul style="list-style-type: none"> <li>The cables from the battery to the traction board or from the board to the motor are loose, oxidized or not correctly connected</li> <li>Check the cables</li> <li>Cycle the keyswitch</li> </ul>
1+3 FLASHES: current sensor. The controller's current sensors have invalid offset readings	<ul style="list-style-type: none"> <li>Cycle the keyswitch</li> <li>Replace the traction board</li> </ul>
1+5 FLASHES: controller severe undertemperature. The heatsink temperature is below -40°C	<ul style="list-style-type: none"> <li>Raise the heatsink temperature to above -40°C</li> <li>Cycle the keyswitch</li> </ul>
1+6 FLASHES: controller severe overtemperature. The heatsink temperature is above 85°C	<ul style="list-style-type: none"> <li>Decrease the heatsink temperature to below 85°C</li> <li>Cycle the keyswitch</li> </ul>
1+7 FLASHES: B+ Undervoltage • Battery voltage below 19V	<ul style="list-style-type: none"> <li>Charge the battery</li> <li>Check battery terminal</li> <li>Cycle the keyswitch</li> </ul>
1+9 FLASHES: B+ Overvoltage • Battery voltage above 28.8V	<ul style="list-style-type: none"> <li>Check that the battery installed is 24V</li> <li>Cycle the keyswitch</li> </ul>
2+3 FLASHES: Speed reduction due to controller temperature too high. Heatsink temperature exceeds 75 °C • The controller is operating in an extremely hot environment • There is excessive load on the vehicle • The controller is incorrectly mounted	<ul style="list-style-type: none"> <li>Return the machine in the field of acceptable temperature</li> <li>Check absorption of the drive wheel</li> <li>Check the mounting of the controller</li> <li>Cycle the keyswitch</li> </ul>
3+7 FLASHES: The motor phase is open	<ul style="list-style-type: none"> <li>Check the crimps and wiring M1-M2</li> <li>Check the wheel drive wiring</li> <li>Cycle the keyswitch</li> </ul>
3+9 FLASHES: Blown B+ fuse	<ul style="list-style-type: none"> <li>Replace the fuse</li> <li>Check the wiring and the B + fuse</li> </ul>
4+4 FLASHES: Sequence error at power up. Forward / reverse microswitch inserted or potentiometer not idle at switch-on	<ul style="list-style-type: none"> <li>Move the pedal to zero position</li> <li>Make sure the pedal returns precisely to zero</li> <li>Check the microswitch on the pedal</li> <li>Cycle the keyswitch</li> </ul>
5+8 FLASHES: The motor has stalled	<ul style="list-style-type: none"> <li>Identify the possible causes of the stall</li> <li>Cycle the keyswitch</li> </ul>
8+8 FLASHES: An internal controller fault occurred	<ul style="list-style-type: none"> <li>Cycle the keyswitch</li> <li>If it persists, replace the controller</li> </ul>
11+8 FLASHES: The controller did not power up correctly	<ul style="list-style-type: none"> <li>Check connections</li> <li>Cycle the keyswitch</li> <li>If it persists, replace the controller</li> </ul>
11+11 FLASHES: motor short	<ul style="list-style-type: none"> <li>Check the crimps and wiring M1-M2</li> <li>Check the wheel drive wiring</li> <li>Cycle the keyswitch</li> </ul>

<b>PROBLEM</b>	<b>CAUSE</b>	<b>SOLUTION</b>
Main brush does not work	Operator not seated	Sit down
	Brush motor switch not on	Engage switch
	Amperometric protection cut-out switch of the motor reducers (OFF)	Reactivate the cut-out switch (ON)
	Faulty brush motor fuse	Replace it
	Faulty brush motor	Replace it or repair it
	Brush motor heat probe tripped	Wait for it to cool down
	Battery charge indicator tripped due to down battery	Recharge the battery
	Dust blocks the brush	Remove it and clean it
	Brush belt is broken	Replace it
The central brush fails to clean uniformly	Brush worn	Replace it
	Brush lifted	Lower it
	Miscellaneous material around brush	Clean it
	Wrong brush adjustment	Adjust brush
Flat battery	Battery in short-circuit	Replace it
	The battery charger doesn't work	Replace it or repair it
The shaker doesn't work	Blown fuse	Replace it
	Faulty filter-shaker	Replace it
	The filter shaker micro-switch is broken	Replace it
Dust inside hood	Filter broken or old.	Have it replaced
	No seal below filter	Have it replaced
Material exit and dust up front	Flap rubber worn or broken	Have it replaced
	Flap blocked open	Release it
No vacuum power	Vacuum fan is off	Open it
	Filters are clogged	Clean it
	Fan belts are broken	Replace it
Side brush does not work	Side brush lever is not engaged	Lower it
	Debris blocks the brush	Remove it and clean it
	Belt is worn or broken	Replace it
	Reducer is faulty	Replace it
Dust and debris leaks out from the machine	The vacuum-fan is closed	Open it
	The rubber flaps are broken	Replace them
	The vacuum-fan is broken	Replace it

## EU DECLARATION OF CONFORMITY

according to Annex II A of the Machinery Directive 2006/42/CE

The manufacturer that places this product on the market:

**EUREKA S.p.A. Unipersonale**  
VIALE DELL'ARTIGIANATO 30/32, 35013 CITTADELLA (PD) - ITALY

formally declares that the product:

### Sweeper RIDER 1201 EB

complies with the following EU Directives:

**2006 / 42 / CE**  
**2014 / 30 / UE**  
**2014 / 35 / UE**  
**2011/ 65 / UE + 2015 / 863**  
**2009 / 125 / CE**

Machinery Directive, Annex 1  
Electromagnetic Compatibility (EMC) Directive  
Low Voltage Directive  
RoHS 3 Directive  
Energy-Related Products (ErP) Directive

The following harmonised and technical standards have been applied:

<b>EN ISO 12100:2010</b>	Safety of machinery - General principles for design - Risk assessment and risk reduction.
<b>EN 60335-1:2013</b>	Household and similar electrical appliances - Safety - Part 1: General requirements.
<b>EN 60335-2-72:2016</b>	Household and similar electrical appliances - Safety - Part 2: Particular requirements for floor treatment machines with or without traction drive, for commercial use.
<b>EN 55014-1:2019</b>	Electromagnetic compatibility - Requirements for household appliances - electric tools and similar apparatus - Part 1: Emission.
<b>EN 55014-2:2015</b>	Electromagnetic compatibility - Requirements for household appliances, electric tools and similar apparatus - Part 2: Immunity - Product family standard.
<b>EN 61000-6-2:2016</b>	Electromagnetic compatibility (EMC) - Part 6-2: Generic standards - Immunity standard for industrial environments.
<b>EN 61000-6-4:2018</b>	Electromagnetic compatibility (EMC) - Part 6-4: Generic standards - Emission standard for industrial environments.
<b>EN 62233:2008</b>	Measurement methods for electromagnetic fields of household appliances and similar apparatus with regard to human exposure.

Legal representative and person authorized to compile the technical file: Antonio Barile

Cittadella, 15/12/2023

EUREKA S.p.A  
(Legal representative)

